

**SCHEMATIC**

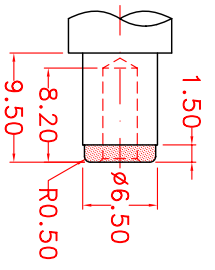

**MATE PLUG**

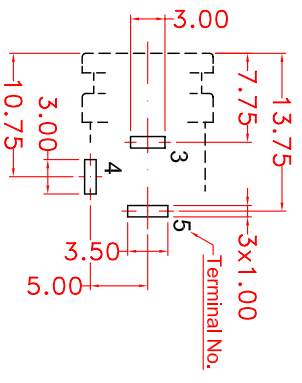

**PIERCING PLAN**

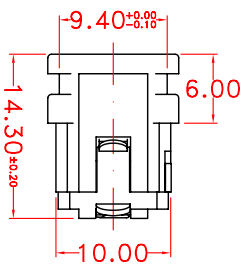
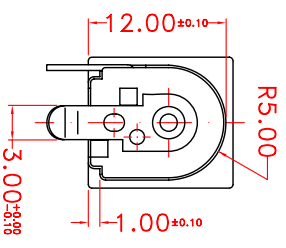
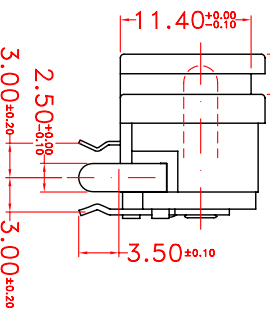
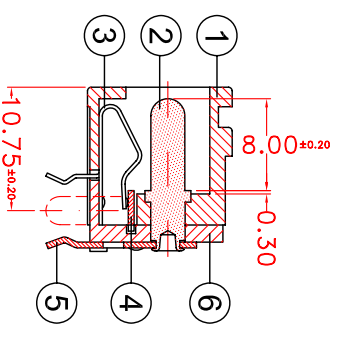
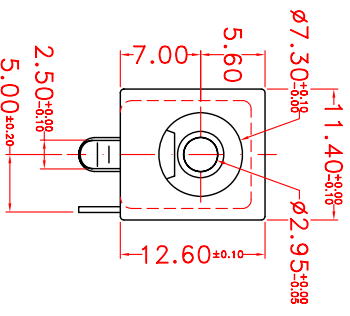

6	HOUSING COVER	1	PA66+G.F.	BLACK COLOR
5	PIN TERMINAL	1	BRASS	Ag PLATED
4	SLEEVE BREAK	1	BRASS	Ag PLATED
3	SLEEVE SPRING	1	SPRING ALLOY	Ag PLATED
2	PIN SHAFT	1	BRASS (Pb<40000ppm)	Ag PLATED
1	HOUSING	1	PBT+G.F.	BLACK COLOR
No.	PARTS	QTY.	MATERIAL	TREATMENT



**THE 3rd ANGLE PROJECTION**

ALL DIMENSIONS TOLERANCE ARE IN ABOVE, UNLESS OTHERWISE SPECIFIED.



**SUN RISE COMPONENT LIMITED**

SCALE : 2.0:1.0	DESIGN BY : So Chung Choi	16-JAN-2003	DESCRIPTION : H=7.00mm PCB DC POWER JACK
UNIT : MILLIMETER (mm)	DRAWN BY : So Chung Choi	07-JAN-2010	MODEL NO. : DC-320-B01-00-PN
TOLERANCE : $\pm 0.20$	CHECKED BY :		CAD FILE : C:\JACK DRAWING\DC310B0100-PN
ANGLE TOL. : $0^{\circ} 30'$	APPROVED BY :		DRAWING FILE : D2K10003

A	B	C	D	E	F	G	H	I	J
No.	DATE	DESCRIPTION / REVISION	REVISED	APPROVED					
1									

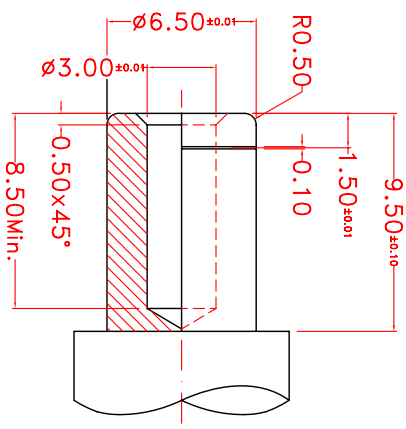

**GAUGE PLUG**

**NOTES:**  
 Gauge plug is made of heat-treated gauge steel.  
 The finish of the gauge plug shall be peak-to-valley height of 0.80 micron or less all over.

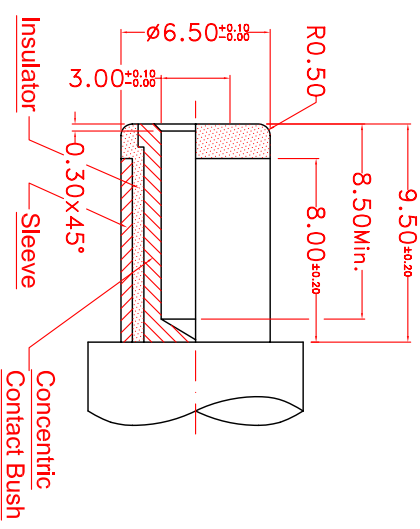

**MATING PLUG**

**NOTES:**  
 The concentric contact bush and the sleeve shall be made of brass, and nickel plated or equivalent.  
 The origin of the mate plug shall be referred to standard of (EIAJ).

No.	PARTS	QTY.	MATERIAL	TREATMENT
8	 <p><b>THE 3rd ANGLE PROJECTION</b></p>			

ALL DIMENSIONS TOLERANCE ARE IN ABOVE, UNLESS OTHERWISE SPECIFIED.	SCALE : 4.0:1.0	DESIGN BY : So Chung Choi	28-MAR-2003	DESCRIPTION : DC POWER JACK APPEDDIX FIG. 1
	UNIT : MILLIMETER (mm)	DRAWN BY : So Chung Choi	07-JAN-2010	MODEL NO. : Dia.6.50mm GAUGE & MATE PLUG
	TOLERANCE : ± 0.20	CHECKED BY :		CAD FILE : C:\PARTS\PLUG\EIAJ-65
	ANGLE TOL. : 0° 30'	APPROVED BY :		DRAWING FILE : D2K10003
				<b>A3</b>



# Product Specification

Model No.: DC-320-B01-00-PN

Description: H=7.00mm Horizontal PCB Mount DC Power Jack

Pin Shaft Diameter:  $\varnothing 2.95\text{mm}$

Packing Method: Bulk Pack

## **1. General**

### 1a. Scope

The jacks should apply to DC low voltage.

### 1b. Gauge Plug

The gauge plug should be as shown in appendix fig. 1 or equivalent.

### 1c. Measurement Condition

All measurement should be done at room ambient temperature and relative humidity 45%-85%.

## **2. Electrical**

### 2a. Rating

DC 16V, 5A.

### 2b. Dielectric Strength

AC 500V at 50-60Hz between insulated conductors for 1 minute, and there should be no breakdown of insulation.

### 2c. Insulation Resistance

Before test or initial minimum  $100\text{M}\Omega$  at DC 500V.

After humidity test minimum  $50\text{M}\Omega$ .

After heat test minimum  $100\text{M}\Omega$ .

After cold test minimum  $100\text{M}\Omega$ .

After soldering test minimum  $100\text{M}\Omega$ .

### 2d. Contact Resistance

Before test or initial maximum  $30\text{m}\Omega$  between terminals and  $50\text{m}\Omega$  between plug and terminal. Apply 1kHz, AC 50mA or less to measured.

#### Between Terminals

After life test maximum  $60\text{m}\Omega$ .

After humidity test maximum  $30\text{m}\Omega$ .

After heat test maximum  $30\text{m}\Omega$ .

After cold test maximum  $30\text{m}\Omega$ .

After soldering test maximum  $30\text{m}\Omega$ .

#### Between Plug and Terminal

After life test maximum  $80\text{m}\Omega$ .

After humidity test maximum  $50\text{m}\Omega$ .

After heat test maximum  $50\text{m}\Omega$ .

After cold test maximum  $50\text{m}\Omega$ .

After soldering test maximum  $50\text{m}\Omega$ .

## **3. Mechanical**

### 3a. Dimensions

Please refer to the mechanical drawing for the shape and all dimension of the product.

### 3b. Insertion and Extraction Force

Force of the jacks should be measure with the Gauge Plug. At the conclusion of this test, the jacks shall comply with a value as specified.

#### Insertion Force

Before test or initial Maximum 2.5kgf.

After life test maximum 2.5kgf.

After humidity test maximum 2.5kgf.

After heat test maximum 2.5kgf.

After cold test maximum 2.5kgf.

After soldering test maximum 2.5kgf.

#### Extraction Force

Before test or initial 0.3kgf to 2.5kgf.

After life test 0.2kgf to 2.5kgf.

After humidity test 0.3kgf to 2.5kgf.

After heat test 0.3kgf to 2.5kgf.

After cold test 0.3kgf to 2.5kgf.

After soldering test 0.3kgf to 2.5kgf.

### 3c. Terminal Strength

A static force of 1000 grams being applied in any direction on the tip of the terminal for a period of 5 seconds. The jacks shall not evidence of mechanical damage, and no loosing the terminal except bending the terminal, causing electrical failure or damages to the extent of practical use.

## 4. Solderability

### 4a. Soldering Condition

#### The Jacks for Printed Circuit Board

The jacks shall be mounted or attached to copper foil clad phenolic laminated board with a suitable hole layout to meet terminal arrangement of the jacks tested, the area to be soldered of the terminal shall be immersed into molten solder at a temperature of  $260^{\circ}\text{C} \pm 5^{\circ}\text{C}$  for a period of  $5 \pm 0.5$  seconds.

#### The Jacks for Hand Soldering

The terminal of jacks tested shall be heated to 2.0mm from a tip of the terminal by a soldering irons to have a capacity of 60 Watts consumption at a temperature controlled of  $350^{\circ}\text{C} \pm 5^{\circ}\text{C}$  for a period of  $3 \pm 0.5$  seconds.

### 4b. Soldering Test

The terminal of jacks tested shall be dipped into soldering flux of GX-7 ASAHI CHEMICAL'S or equivalent for a period of 5 - 10 seconds to pre-flux and shall be immersed into  $235^{\circ}\text{C} \pm 5^{\circ}\text{C}$  molten solder of (Tin 63% and Lead 37%) or equivalent to 2.0mm  $\pm$  0.5mm from tip of terminal for dwell time of  $3 \pm 0.5$  seconds. At the conclusion of this test, the tested area shall be covered more than 75% of immersed area with solder.

## 5. Environmental

### 5a. Humidity Test

The jacks shall be exposed in a humidity chamber at temperature of  $40^{\circ}\text{C} \pm 2^{\circ}\text{C}$  and at a relative humidity of 85% to 90% for 48 hours (2 days), and in normal room ambient condition for 30-60 minutes to stabilize measurement. At the conclusion of this test, the jacks shall comply with paragraphs 2a, 2b, 2c, 2d and 3b.

### 5b. Heat Test

The jacks shall be exposed in a heat chamber at temperature of  $70^{\circ}\text{C} \pm 2^{\circ}\text{C}$  and at a relative humidity of below 50% for a period of 48 hours (2 days), and in normal room ambient condition for 30-60 minutes to stabilize measurement. At the conclusion of this test, the jacks shall comply with paragraphs 2a, 2b, 2c, 2d and 3b.

5c. Cold Test

The jacks shall be exposed in a cold chamber at temperature of  $-40^{\circ}\text{C} \pm 2^{\circ}\text{C}$  for a period of 48 hours (2 days), and in normal room ambient condition of 30-60 minutes to stabilize measurement. At the conclusion of this test, the jacks shall comply with paragraphs 2a, 2b, 2c, 2d and 3b.

**6. Life Test**

6a. Test Condition

Life test shall be done at (15 - 18 cycles / minute) Unloaded.

Before the test, apply contact grease to the sliding surface of the plug in order to prevent the part from over-heating and wearing due to friction.

6b. Life of Jacks

After 5,000 cycles of continuous insertion and extraction. At the conclusion of this test, the jacks shall comply with paragraphs 2a, 2b, 2c, 2d and 3b.

**7. Precautions in Handling**

Please take note of the following points

7a. Operating temperature and humidity range

Temperature:  $-25^{\circ}\text{C} \sim 70^{\circ}\text{C}$  / Humidity: 70% RH or less.

7b. Recommended to manual soldering conditions (by solder iron)

Bit temperature:  $350^{\circ}\text{C} \pm 5^{\circ}\text{C}$

Solder iron:  $3 \pm 0.5$  second

Load on terminal: approx. 0.5N (50g) or less.

7c. Storage

This jack is silvering plated. Therefore this jack should not be left with the package open. In case plating sulfurates soldering trouble or contact trouble will happen. The shelf-life remains 3 months under the formal condition.

7d. Washing

This jack shall not be washed. In case this jack is washed contact trouble will happen.

7e. Other necessary item

Please consult with Sun Rise before using the unit or performing tests under conditions other than those listed in these specifications.

\*\*\* END \*\*\*