



## LCD MODULE SPECIFICATION

**MODEL NO.**

**BC1602E series**

FOR MESSRS:

---

ON DATE OF:

---

APPROVED BY:

---



## **C O N T E N T S**

1. Numbering System
2. Precautions in use of LCD Modules
3. General Specification
4. Absolute Maximum Rating
5. Electrical Characteristics
6. Optical Characteristics
7. Interface Pin Function
8. Power supply for LCD Module and LCD operating voltage adjustment
9. Backlight information
10. Quality Assurance
11. Reliability
12. Appendix (Drawing , EL inverter data , KS0066 controller data)
  - 12-1 Drawing
  - 12-2 KS0066 controller data
    - 12-2.1 Function description
    - 12-2.2 C.G ROM table. table 2
    - 12-2.3 Instruction table
    - 12-2.4 Timing characteristics
    - 12-2.5 Initializing soft ware of LCM



## 1. Numbering System

| <u>B</u> | <u>C</u> | <u>2004</u> | <u>A</u> | <u>G</u> | <u>P</u> | <u>L</u> | <u>E</u> | <u>B</u> | <u>xxx</u> |
|----------|----------|-------------|----------|----------|----------|----------|----------|----------|------------|
| 0        | 1        | 2           | 3        | 4        | 5        | 6        | 7        | 8        | 9          |

|          |                                      |   |  |
|----------|--------------------------------------|---|--|
| <b>0</b> | Brand                                | Bolymin   |  |
| <b>1</b> | Module Type                          | C= character type<br>G= graphic type<br>P= TAB/TCP type   | O= COG type<br>F= COF type   |
| <b>2</b> | Format                               | 2002=20 characters, 4 lines<br>12232= 122 x 32 dots   |  |
| <b>3</b> | Version No.                          | A type  |  |
| <b>4</b> | LCD Color                            | G=STN/gray<br>Y=STN/yellow-green<br>C=color STN   | B=STN/blue<br>F=FSTN<br>T=TN   |
| <b>5</b> | LCD Type                             | R=positive/reflective<br>P=positive/transflective   | M=positive/transmissive<br>N=negative/transmissive                                     |
| <b>6</b> | Backlight type/color                 | L=LED array/<br>yellow-green<br>H=LED edge/white<br>R=LED array/red<br>G=LED<br>edge/yellow-green                           | D=LED edge/blue<br>E=EL/white<br>B=EL/blue<br>C=CCFL/white                             |
| <b>7</b> | CGRAM Font                           | J=English/Japanese<br>Font<br>E=English/European<br>Font  | C=English/Cyrillic<br>Font<br>H=English/Hebrew<br>Font                                 |
| <b>8</b> | View Angle/<br>Operating Temperature | B=Bottom/Normal<br>Temperature<br>H=Bottom/Wide<br>Temperature<br>U=Bottom/Ultra wide<br>Temperature                        | T=Top/Normal<br>Temperature<br>W=Top/Wide<br>Temperature<br>C=9H/Normal<br>Temperature |
| <b>9</b> | Special Code                         | 3=3 volt logic power<br>supply<br>n=negative voltage for<br>LCD<br>c=cable/connector<br>xxx=to be assigned on<br>data sheet | t=temperature<br>compensation for LCD<br>p=touch panel                                 |



## 2. Precaution in use of LCD Module

- (1) Avoid applying excessive shocks to the module or making any alterations or modifications to it.
- (2) Don't make extra holes on the printed circuit board, modify its shape or change the components of LCD module.
- (3) Don't disassemble the LCM.
- (4) Don't operate it above the absolute maximum rating.
- (5) Don't drop, bend or twist LCM.
- (6) Soldering: only to the I/O terminals.
- (7) Storage: please storage in anti-static electricity container and clean environment.
- (8) Don't touch the elastmer connector, especially insert a backlight panel(EL or CCFL)

## 3. General Specification

### (1) Mechanical Dimension

| Item                              | Dimension  | Unit |
|-----------------------------------|--|------|
| Number of Characters              | 16characters x 2 Lines   | —    |
| Module dimension<br>( L x W x H ) | 122.2 x 44.0 x 13.1 (Max)– LED B/L<br>LED edge B/L(white, blue )<br>122.2 x 44.0 x 9.3 (Max/) – EL or No B/L | mm   |
| View area                         | 99.0 x 24.0  | mm   |
| Active area                       | 94.84 x 20.0   | mm   |
| Dot size                          | 0.92 x 1.1   | mm   |
| Dot pitch                         | 0.98 x 1.16  | mm   |
| Character size ( L x W )          | 4.84 x 8.06  | mm   |
| Character pitch ( L x W )         | 6.0 x 9.66   | mm   |

### (2) Controller IC: **KS0066 (or Equivalent) controller**

### (3) Temperature Range

|           | Normal      | Wide       |
|-----------|-------------|------------|
| Operating | 0 ~+50°C    | -20 ~+70°C |
| Storage   | -10 ~+ 60°C | -30 ~+80°C |



## 4. Absolute Maximum Ratings

### 4.1 Electrical Absolute Maximum Ratings

(V<sub>SS</sub>=0V, Ta=25°C)

| Item                     | Symbol                           | Min             | Typ | Max             | Unit |
|--------------------------|----------------------------------|-----------------|-----|-----------------|------|
| Supply Voltage For Logic | V <sub>DD</sub> -V <sub>SS</sub> | -0.3            | —   | 7               | V    |
| Supply Voltage For LCD   | V <sub>DD</sub> -V <sub>O</sub>  | -0.3            | —   | 5.5             | V    |
| Input Voltage            | V <sub>I</sub>                   | V <sub>SS</sub> | —   | V <sub>DD</sub> | V    |
| Normal Type              | T <sub>OP</sub>                  | 0               | —   | +50             | °C   |
|                          | T <sub>STG</sub>                 | -10             | —   | +60             | °C   |
| Wide Temperature Type    | T <sub>OP</sub>                  | -20             | —   | +70             | °C   |
|                          | T <sub>STG</sub>                 | -30             | —   | +80             | °C   |

## 5. Electrical Characteristics

| Item   | Symbol                           | Condition           | Min | Typ        | Max             | Unit |
|--|----------------------------------|---------------------|-----|------------|-----------------|------|
| Supply Voltage For Logic                       | V <sub>DD</sub> -V <sub>SS</sub> | —                   | 3.0 | —          | 5.5             | V    |
| Supply Voltage For LCD<br><br>* Wide Temp、Type | V <sub>DD</sub> -V <sub>O</sub>  | * Ta=-20°C          | —   | 5.0        | —               | V    |
|  |                                  | Ta=0°C              | —   | —          | —               | V    |
|  |                                  | Ta=25°C             | —   | <b>4.2</b> | —               | V    |
|  |                                  | Ta=50°C             | —   | —          | —               | V    |
|  |                                  | * Ta=+70°C          | —   | 3.8        | —               | V    |
| Input High Volt.                               | V <sub>IH</sub>                  | —                   | 2.2 | —          | V <sub>DD</sub> | V    |
| Input Low Volt.                                | V <sub>IL</sub>                  | —                   | —   | —          | 0.6             | V    |
| Output High Volt.                              | V <sub>OH</sub>                  | —                   | 2.4 | —          | —               | V    |
| Output Low Volt.                               | V <sub>OL</sub>                  | —                   | —   | —          | 0.4             | V    |
| Supply Current                                 | I <sub>DD</sub>                  | V <sub>DD</sub> =5V | —   | 1.2        | —               | mA   |



## 6. Optical Characteristics

### a. STN

| Item                  | Symbol        | Condition   | Min. | Typ. | Max. | Unit |
|-----------------------|---------------|-------------|------|------|------|------|
| View Angle            | (V) $\theta$  | $CR \geq 2$ | 10   |      | 45   | deg  |
|                       | (H) $\varphi$ | $CR \geq 2$ | -30  |      | 30   | deg  |
| Contrast Ratio        | CR            | —           |      | 3    |      | —    |
| Response Time<br>25°C | T rise        | —           |      | 100  | 150  | ms   |
|                       | T fall        | —           |      | 150  | 200  | ms   |

### b. FSTN

| Item                  | Symbol        | Condition   | Min. | Typ. | Max. | Unit |
|-----------------------|---------------|-------------|------|------|------|------|
| View Angle            | (V) $\theta$  | $CR \geq 3$ | 10   |      | 60   | deg  |
|                       | (H) $\varphi$ | $CR \geq 3$ | -45  |      | 45   | deg  |
| Contrast Ratio        | CR            | —           |      | 5    |      | —    |
| Response Time<br>25°C | T rise        | —           |      | 100  | 150  | ms   |
|                       | T fall        | —           |      | 150  | 200  | ms   |



6.1 Definitions

■ View Angles

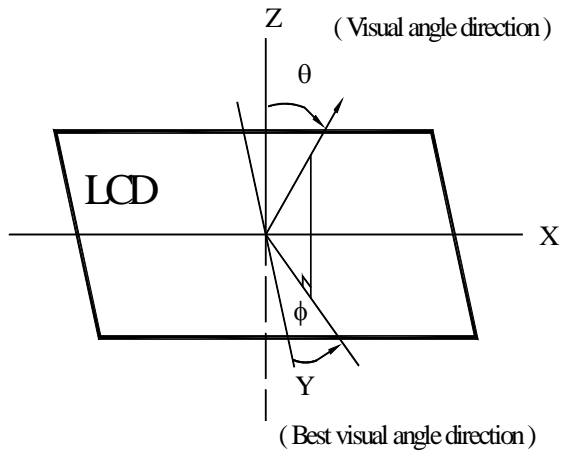

■ Contrast Ratio

$$CR = \frac{\text{Brightness at selected state (BS)}}{\text{Brightness at non-selected state (Bns)}}$$

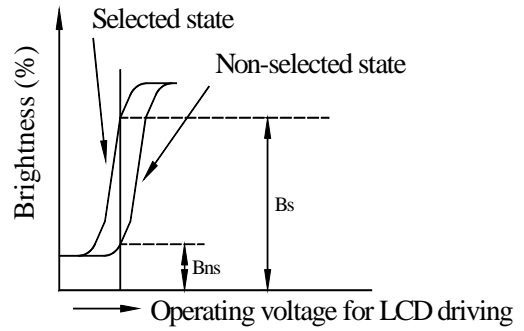

■ Response Time

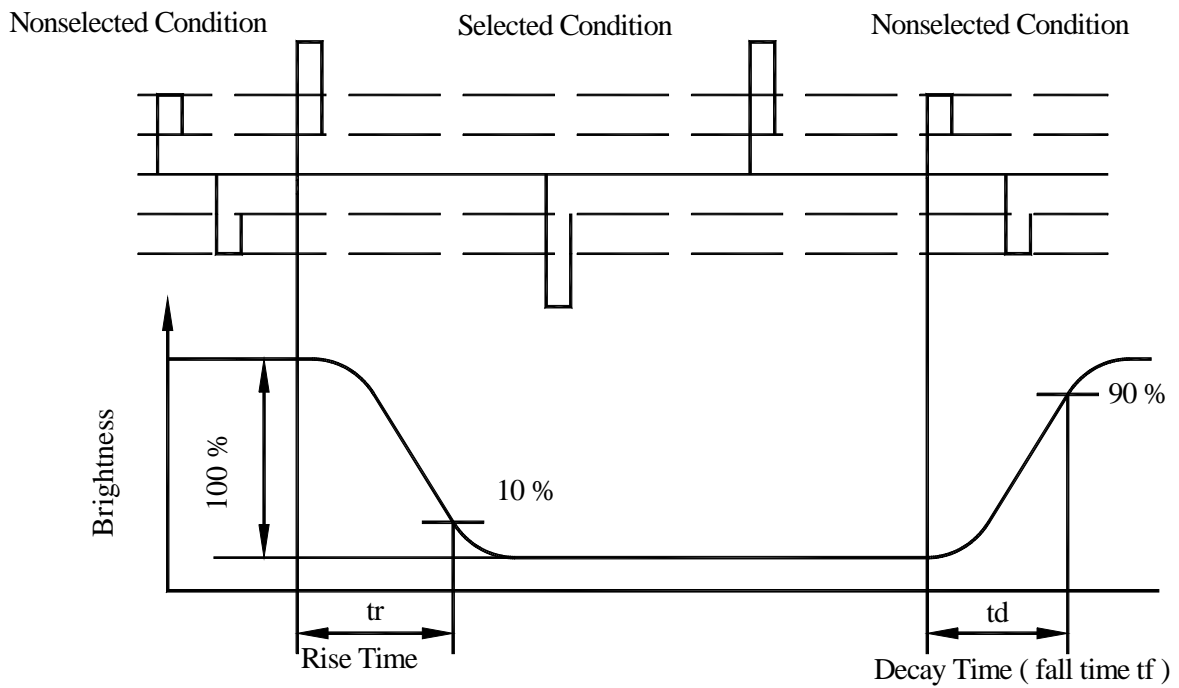



## 7. Interface Pin Function

| Pin No. | Symbol  | Level      | Description  |
|---------|---------|------------|--|
| 1       | Vss     | 0V         | Ground   |
| 2       | Vdd     | 5.0V       | Supply Voltage for logic ( <b>option +3.0V</b> )                             |
| 3       | Vo      | (Variable) | Operating voltage for LCD  |
| 4       | RS      | H/L        | H: DATA, L: Instruction code   |
| 5       | R/W     | H/L        | H: Read(MPU→Module) L: Write(MPU→Module)                                     |
| 6       | E       | H,H→L      | Chip enable signal   |
| 7       | DB0     | H/L        | Data bit 0   |
| 8       | DB1     | H/L        | Data bit 1   |
| 9       | DB2     | H/L        | Data bit 2   |
| 10      | DB3     | H/L        | Data bit 3   |
| 11      | DB4     | H/L        | Data bit 4   |
| 12      | DB5     | H/L        | Data bit 5   |
| 13      | DB6     | H/L        | Data bit 6   |
| 14      | DB7     | H/L        | Data bit 7   |
| 15      | A / Vee | —          | Power supply for LED backlight ( + ) /<br>Negative voltage output (optional) |
| 16      | K       | —          | Power supply for LED backlight ( - )   |



## 8. Power Supply for LCD Module and LCD Operating Voltage a Adjustment

\* Standard Type

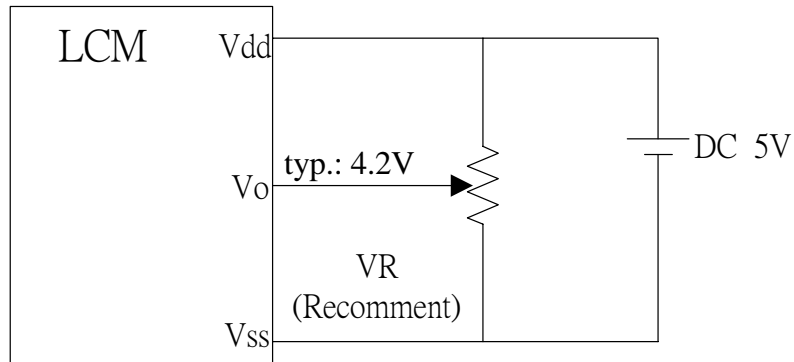

\*(Option)LCM operating on " DC 3V " input with external negative voltage

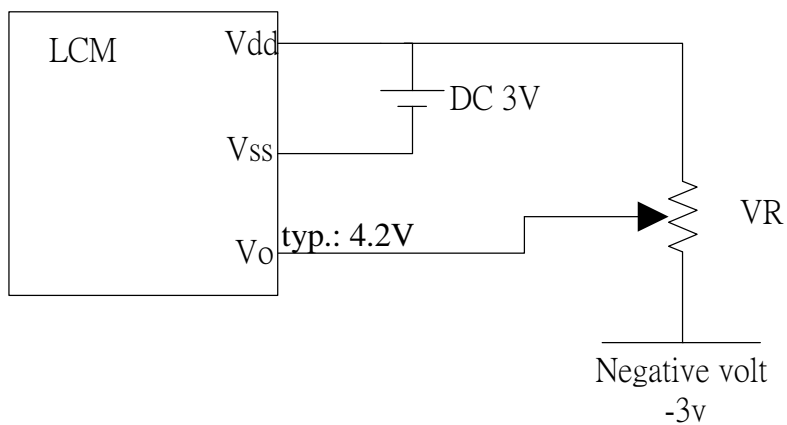

\*(Option) LCM operating on " DC 3V " input with built-in negative voltage

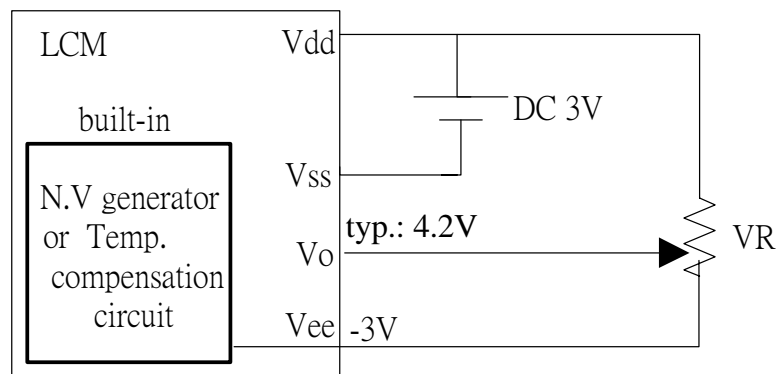



## 9. Backlight Information

### 9.1 Specification

#### (1) LED array / yellow-green

| Parameter          | Symbol           | Min | Typ    | Max | Unit              | Test Condition           |
|--------------------|------------------|-----|--------|-----|-------------------|--------------------------|
| Supply Current     | I <sub>LED</sub> | —   | 280    | —   | mA                | V=4.2V                   |
| Supply Voltage     | V                | —   | 4.2    | 4.3 | V                 | —                        |
| Reverse Voltage    | V <sub>R</sub>   | —   | —      | 8   | V                 | —                        |
| Luminous Intensity | I <sub>V</sub>   | 60  | —      | —   | cd/m <sup>2</sup> | I <sub>LED</sub> =280mA  |
| Wave Length        | λ <sub>p</sub>   | —   | 574    | —   | nm                | I <sub>LED</sub> =280mA  |
| Life Time          | —                | —   | 100000 | —   | Hr.               | I <sub>LED</sub> ≤ 280mA |
| Color              | Yellow Green     |     |        |     |                   |                          |

#### (1) LED array / red

| Parameter          | Symbol           | Min | Typ   | Max | Unit              | Test Condition           |
|--------------------|------------------|-----|-------|-----|-------------------|--------------------------|
| Supply Current     | I <sub>LED</sub> | —   | 280   | —   | mA                | V=3.9V                   |
| Supply Voltage     | V                | —   | 3.9   | 4.0 | V                 | —                        |
| Reverse Voltage    | V <sub>R</sub>   | —   | —     | 8   | V                 | —                        |
| Luminous Intensity | I <sub>V</sub>   | 300 | 350   | —   | cd/m <sup>2</sup> | I <sub>LED</sub> =280mA  |
| Wave Length        | λ <sub>p</sub>   | —   | 665   | —   | nm                | I <sub>LED</sub> =280mA  |
| Life Time          | —                | —   | 30000 | —   | Hr.               | I <sub>LED</sub> ≤ 280mA |
| Color              | Red              |     |       |     |                   |                          |



## (2) LED edge/ white or blue

| Parameter          | Symbol           | Min | Typ   | Max | Unit              | Test Condition          |
|--------------------|------------------|-----|-------|-----|-------------------|-------------------------|
| Supply Current     | I <sub>LED</sub> | —   | 20    | 30  | mA                | V=3.2V                  |
| Supply Voltage     | V                | —   | 3.2   | 3.3 | V                 |                         |
| Reverse Voltage    | V <sub>R</sub>   | —   | —     | 8   | V                 |                         |
| Luminous Intensity | I <sub>V</sub>   | 50  | —     | —   | cd/m <sup>2</sup> | I <sub>LED</sub> ≤ 20mA |
| Life Time          |                  | —   | 35000 | —   | Hr.               | I <sub>LED</sub> ≤ 20mA |
| Color              | White(Blue)      |     |       |     |                   |                         |

## (3) EL /White( blue)

| Parameter                | Symbol             | Min | Typ                        | Max | Unit | Test Condition   |
|--------------------------|--------------------|-----|----------------------------|-----|------|------------------|
| Voltage                  | V <sub>rms</sub>   | --  | 110 (AC)                   |     | --   |                  |
| Frequency                | HZ                 | --  | 400                        |     | --   |                  |
| Brightness*              | cd/m <sup>2</sup>  | 48  | 60                         |     | --   | 110Vrms<br>400Hz |
| CIE Chromaticity Diagram | X                  | --  | 0.2901 white<br>0.182 blue |     | --   |                  |
|                          | Y                  | --  | 0.3608 white<br>0.46 blue  |     | --   |                  |
| Current Dissipation      | mA/cm <sup>2</sup> | --  | 1.33                       |     | --   |                  |
| Power Dissipation        | mW/cm <sup>2</sup> | --  | 26.29                      |     | --   |                  |
| Color                    | White(Blue)        |     |                            |     |      |                  |



9.2 Backlight driving methods

a. LED B/L drive from pin15 (LED+) pin16 (LED-)

a.1 array / yellow-green

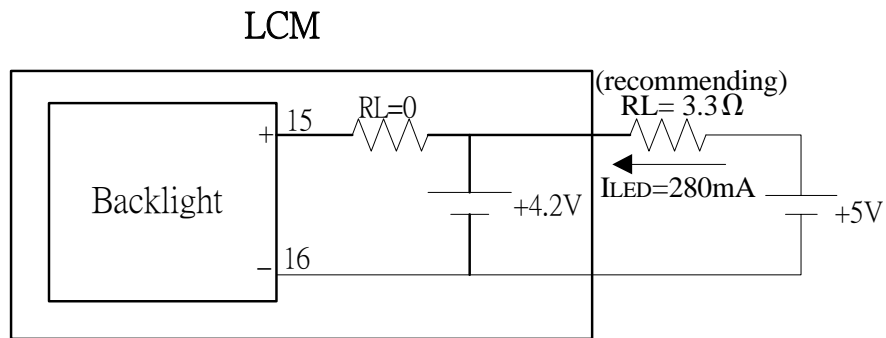

a.2 LED white or blue

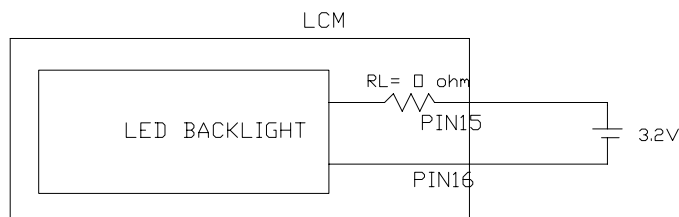

b. LED B/L drive from A.K directly

b.1 array / yellow-green

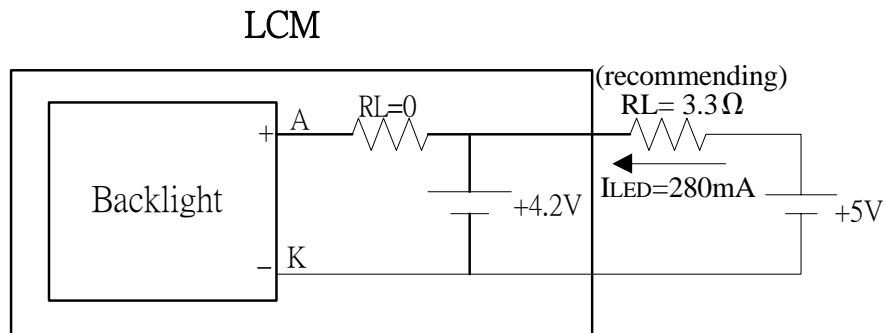



c. \* (Option) LED B/L drive from pin1 (Vss) pin2 (Vdd)

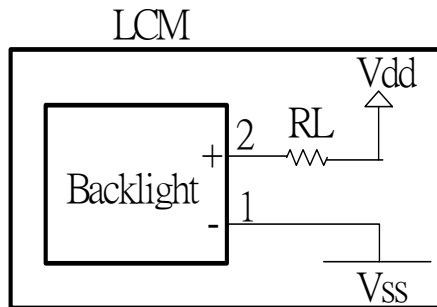

- (1) Jump 1,2 Short
- (2) Current Resistor required on RL
- (3) Jump 15,16 open
- (4) To be sure of enough current supply for both Vdd + LED B/L

d. E/L B/L driven from A.K cable directly

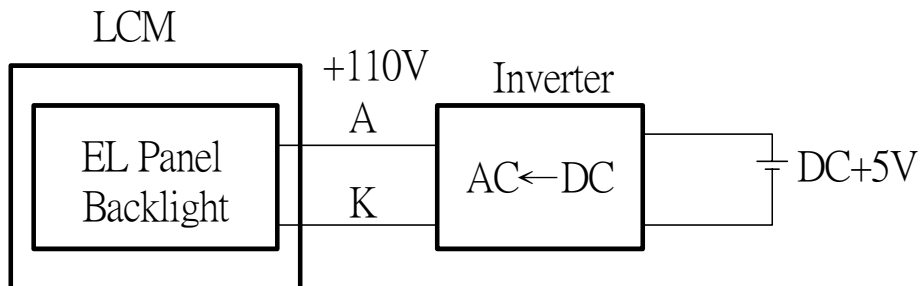



## 10. Quality Assurance

### 10.1 Inspection conditions

The LCD shall be inspected under 40W white fluorescent light.

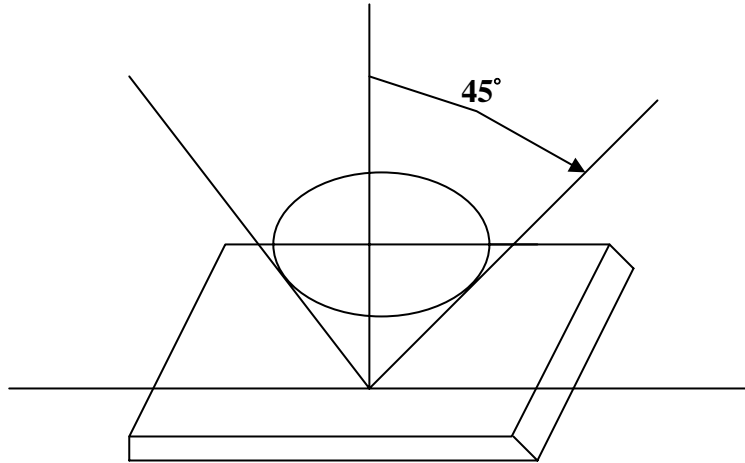

### Definition of applicable Zones

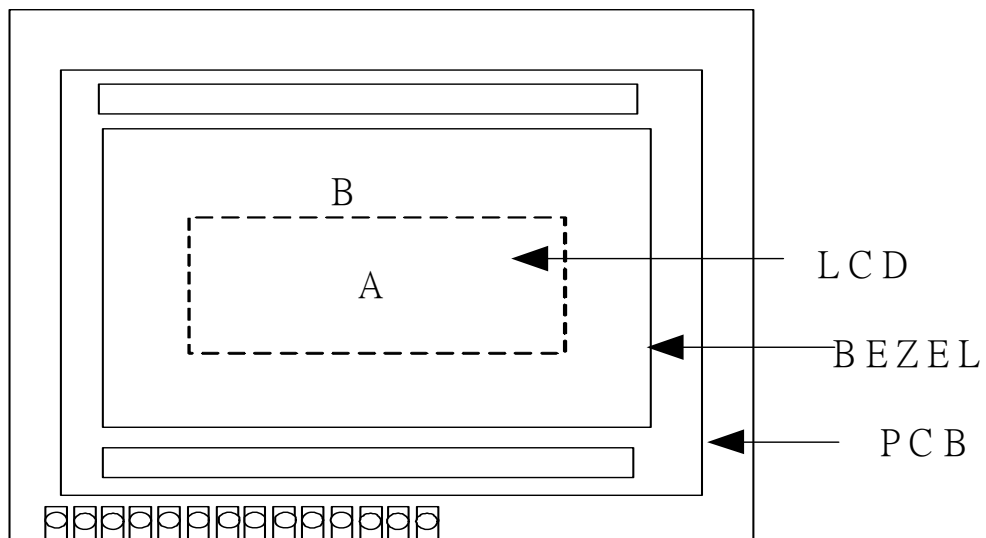

A : Display Area

B : Non-Display Area



10.2 Inspection Parameters

| NO.                    | Parameter                               | Criteria  |                     |                   |                   |                  |                  |                  |   |               |   |   |       |               |                        |   |       |                        |              |               |              |   |              |               |   |   |   |           |   |   |
|------------------------|---|---|---------------------|-------------------|-------------------|------------------|------------------|------------------|---|---------------|---|---|-------|---------------|------------------------|---|-------|------------------------|--------------|---------------|--------------|---|--------------|---------------|---|---|---|-----------|---|---|
| 1                      | Black or White spots                    | <table border="1"> <thead> <tr> <th rowspan="2">Zone<br/>Dimension</th> <th colspan="2">Acceptable Number</th> <th rowspan="2">Class Of Defects</th> <th rowspan="2">Acceptable Level</th> </tr> <tr> <th>A</th> <th>B</th> </tr> </thead> <tbody> <tr> <td><math>D &lt; 0.15</math></td> <td>*</td> <td>*</td> <td rowspan="4">Minor</td> <td rowspan="4">2.5</td> </tr> <tr> <td><math>0.15 \leq D \leq 0.2</math></td> <td>4</td> <td>4</td> </tr> <tr> <td><math>0.2 \leq D \leq 0.25</math></td> <td>2</td> <td>2</td> </tr> <tr> <td><math>D \leq 0.3</math></td> <td>0</td> <td>1</td> </tr> </tbody> </table> <p><math>D = (\text{Long} + \text{Short})/2</math>      *: Disregard</p>  | Zone<br>Dimension   | Acceptable Number |                   | Class Of Defects | Acceptable Level | A                | B | $D < 0.15$    | * | * | Minor | 2.5           | $0.15 \leq D \leq 0.2$ | 4 | 4     | $0.2 \leq D \leq 0.25$ | 2            | 2             | $D \leq 0.3$ | 0 | 1            |               |   |   |   |           |   |   |
| Zone<br>Dimension      | Acceptable Number                       |   |                     | Class Of Defects  | Acceptable Level  |                  |                  |                  |   |               |   |   |       |               |                        |   |       |                        |              |               |              |   |              |               |   |   |   |           |   |   |
|                        | A                                       | B   |                     |                   |                   |                  |                  |                  |   |               |   |   |       |               |                        |   |       |                        |              |               |              |   |              |               |   |   |   |           |   |   |
| $D < 0.15$             | *                                       | *   | Minor               | 2.5               |                   |                  |                  |                  |   |               |   |   |       |               |                        |   |       |                        |              |               |              |   |              |               |   |   |   |           |   |   |
| $0.15 \leq D \leq 0.2$ | 4                                       | 4   |                     |                   |                   |                  |                  |                  |   |               |   |   |       |               |                        |   |       |                        |              |               |              |   |              |               |   |   |   |           |   |   |
| $0.2 \leq D \leq 0.25$ | 2                                       | 2   |                     |                   |                   |                  |                  |                  |   |               |   |   |       |               |                        |   |       |                        |              |               |              |   |              |               |   |   |   |           |   |   |
| $D \leq 0.3$           | 0                                       | 1   |                     |                   |                   |                  |                  |                  |   |               |   |   |       |               |                        |   |       |                        |              |               |              |   |              |               |   |   |   |           |   |   |
| 2                      | Scratch, Substances                     | <table border="1"> <thead> <tr> <th colspan="2">Zone<br/>X(mm) Y(mm)</th> <th colspan="2">Acceptable Number</th> <th rowspan="2">Class Of Defects</th> <th rowspan="2">Acceptable Level</th> </tr> <tr> <th>A</th> <th>B</th> <th>A</th> <th>B</th> </tr> </thead> <tbody> <tr> <td>*</td> <td><math>0.04 \geq W</math></td> <td>*</td> <td>*</td> <td rowspan="4">Minor</td> <td rowspan="4">2.5</td> </tr> <tr> <td><math>3.0 \geq L</math></td> <td><math>0.06 \geq W</math></td> <td>4</td> <td>4</td> </tr> <tr> <td><math>2.0 \geq L</math></td> <td><math>0.08 \geq W</math></td> <td>2</td> <td>3</td> </tr> <tr> <td>—</td> <td><math>0.1 &lt; W</math></td> <td>0</td> <td>1</td> </tr> </tbody> </table> <p>X: Length    Y: Width    *: Disregard<br/>Total defects should not exceed 4/module</p> | Zone<br>X(mm) Y(mm) |                   | Acceptable Number |                  | Class Of Defects | Acceptable Level | A | B             | A | B | *     | $0.04 \geq W$ | *                      | * | Minor | 2.5                    | $3.0 \geq L$ | $0.06 \geq W$ | 4            | 4 | $2.0 \geq L$ | $0.08 \geq W$ | 2 | 3 | — | $0.1 < W$ | 0 | 1 |
| Zone<br>X(mm) Y(mm)    |   | Acceptable Number   |                     | Class Of Defects  | Acceptable Level  |                  |                  |                  |   |               |   |   |       |               |                        |   |       |                        |              |               |              |   |              |               |   |   |   |           |   |   |
| A                      | B                                       | A   | B                   |                   |                   |                  |                  |                  |   |               |   |   |       |               |                        |   |       |                        |              |               |              |   |              |               |   |   |   |           |   |   |
| *                      | $0.04 \geq W$                           | *   | *                   | Minor             | 2.5               |                  |                  |                  |   |               |   |   |       |               |                        |   |       |                        |              |               |              |   |              |               |   |   |   |           |   |   |
| $3.0 \geq L$           | $0.06 \geq W$                           | 4   | 4                   |                   |                   |                  |                  |                  |   |               |   |   |       |               |                        |   |       |                        |              |               |              |   |              |               |   |   |   |           |   |   |
| $2.0 \geq L$           | $0.08 \geq W$                           | 2   | 3                   |                   |                   |                  |                  |                  |   |               |   |   |       |               |                        |   |       |                        |              |               |              |   |              |               |   |   |   |           |   |   |
| —                      | $0.1 < W$                               | 0   | 1                   |                   |                   |                  |                  |                  |   |               |   |   |       |               |                        |   |       |                        |              |               |              |   |              |               |   |   |   |           |   |   |
| 3                      | Air Bubbles (between glass & polarizer) | <table border="1"> <thead> <tr> <th rowspan="2">Zone<br/>Dimension</th> <th colspan="2">Acceptable Number</th> <th rowspan="2">Class Of Defects</th> <th rowspan="2">Acceptable Level</th> </tr> <tr> <th>A</th> <th>B</th> </tr> </thead> <tbody> <tr> <td><math>D \leq 0.15</math></td> <td>*</td> <td>*</td> <td rowspan="3">Minor</td> <td rowspan="3">2.5</td> </tr> <tr> <td><math>0.15 &lt; D \leq 0.25</math></td> <td>2</td> <td>*</td> </tr> <tr> <td><math>0.25 &lt; D</math></td> <td>0</td> <td>1</td> </tr> </tbody> </table> <p>*: Disregard<br/>Total defects shall not excess 3/module.</p>  | Zone<br>Dimension   | Acceptable Number |                   | Class Of Defects | Acceptable Level | A                | B | $D \leq 0.15$ | * | * | Minor | 2.5           | $0.15 < D \leq 0.25$   | 2 | *     | $0.25 < D$             | 0            | 1             |              |   |              |               |   |   |   |           |   |   |
| Zone<br>Dimension      | Acceptable Number                       |   |                     | Class Of Defects  | Acceptable Level  |                  |                  |                  |   |               |   |   |       |               |                        |   |       |                        |              |               |              |   |              |               |   |   |   |           |   |   |
|                        | A                                       | B   |                     |                   |                   |                  |                  |                  |   |               |   |   |       |               |                        |   |       |                        |              |               |              |   |              |               |   |   |   |           |   |   |
| $D \leq 0.15$          | *                                       | *   | Minor               | 2.5               |                   |                  |                  |                  |   |               |   |   |       |               |                        |   |       |                        |              |               |              |   |              |               |   |   |   |           |   |   |
| $0.15 < D \leq 0.25$   | 2                                       | *   |                     |                   |                   |                  |                  |                  |   |               |   |   |       |               |                        |   |       |                        |              |               |              |   |              |               |   |   |   |           |   |   |
| $0.25 < D$             | 0                                       | 1   |                     |                   |                   |                  |                  |                  |   |               |   |   |       |               |                        |   |       |                        |              |               |              |   |              |               |   |   |   |           |   |   |

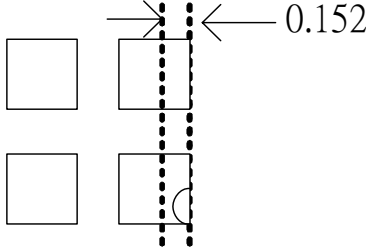
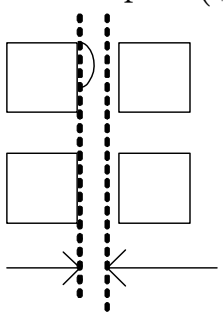
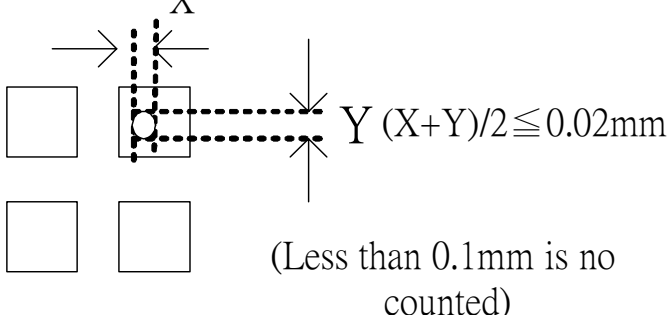
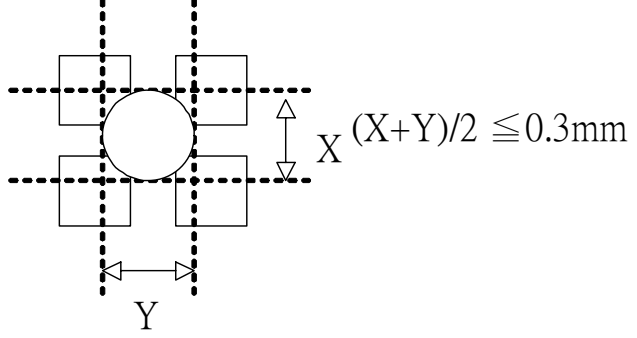

|   |            |   |
|---|------------|---|
| 4 | Uniformity | <p>(1) Pixel shape (with Dent)</p>  <p>(2) Pixel shape (With Projection)</p>  <p>Should not be connected to next pixel</p> <p>(3) Pin hole</p>  <p><math>(X+Y)/2 \leq 0.02\text{mm}</math></p> <p>(Less than 0.1mm is no counted)</p> <p>(4) Deformation</p>  <p><math>(X+Y)/2 \leq 0.3\text{mm}</math></p> <p>Total acceptable number : 1/pixel,5/cell</p> |
|---|------------|---|



## 11. Reliability

### Content of Reliability Test

| Environmental Test |   |  |   |                     |
|--------------------|---|--|---|---------------------|
| No.                | Test Item                               | Content of Test  | Test Condition  | Applicable Standard |
| 1                  | High Temperature storage                | Endurance test applying the high storage temperature for a long time.  | 60°C<br>200hrs  | —                   |
| 2                  | Low Temperature storage                 | Endurance test applying the high storage temperature for a long time.  | -20°C<br>200hrs   | —                   |
| 3                  | High Temperature Operation              | Endurance test applying the electric stress (Voltage & Current) and the thermal stress to the element for a long time.   | 50°C<br>200hrs  | —                   |
| 4                  | Low Temperature Operation               | Endurance test applying the electric stress under low temperature for a long time.   | 0°C<br>200hrs   | —                   |
| 5                  | High Temperature/<br>Humidity Storage   | Endurance test applying the high temperature and high humidity storage for a long time.  | 60°C, 90%RH<br>96hrs                                    | —                   |
| 6                  | High Temperature/<br>Humidity Operation | Endurance test applying the electric stress (Voltage & Current) and temperature / humidity stress to the element for a long time.  | 40°C, 90%RH<br>96hrs                                    | —                   |
| 7                  | Temperature Cycle                       | Endurance test applying the low and high temperature cycle.<br><div style="text-align: center;"> <math>\leftarrow</math> -20°C    25°C    60°C <math>\rightarrow</math><br/>           30min    5min    30min<br/>           ───────────<br/>           1 cycle         </div> | -20°C/60°C<br>10 cycles                                 | —                   |
| Mechanical Test    |   |  |   |                     |
| 8                  | Vibration test                          | Endurance test applying the vibration during transportation and using.   | 10~22Hz→1.5mmp-p<br>22~500Hz→1.5G<br>Total 0.5hrs       | —                   |
| 9                  | Shock test                              | Constructional and mechanical endurance test applying the shock during transportation.   | 50G Half sign wave 11 msdc<br>3 times of each direction | —                   |
| 10                 | Atmospheric pressure test               | Endurance test applying the atmospheric pressure during transportation by air.   | 115mbar<br>40hrs  | —                   |
| Others             |   |  |   |                     |
| 11                 | Static electricity test                 | Endurance test applying the electric stress to the terminal.   | VS=800V, RS=1.5kΩ<br>CS=100pF<br>1 time                 | —                   |

\*\*\*Supply voltage for logic system=5V. Supply voltage for LCD system =Operating voltage at 25°C



12. Appendix ( Drawing , EL inverter data , KS0066 controller data)

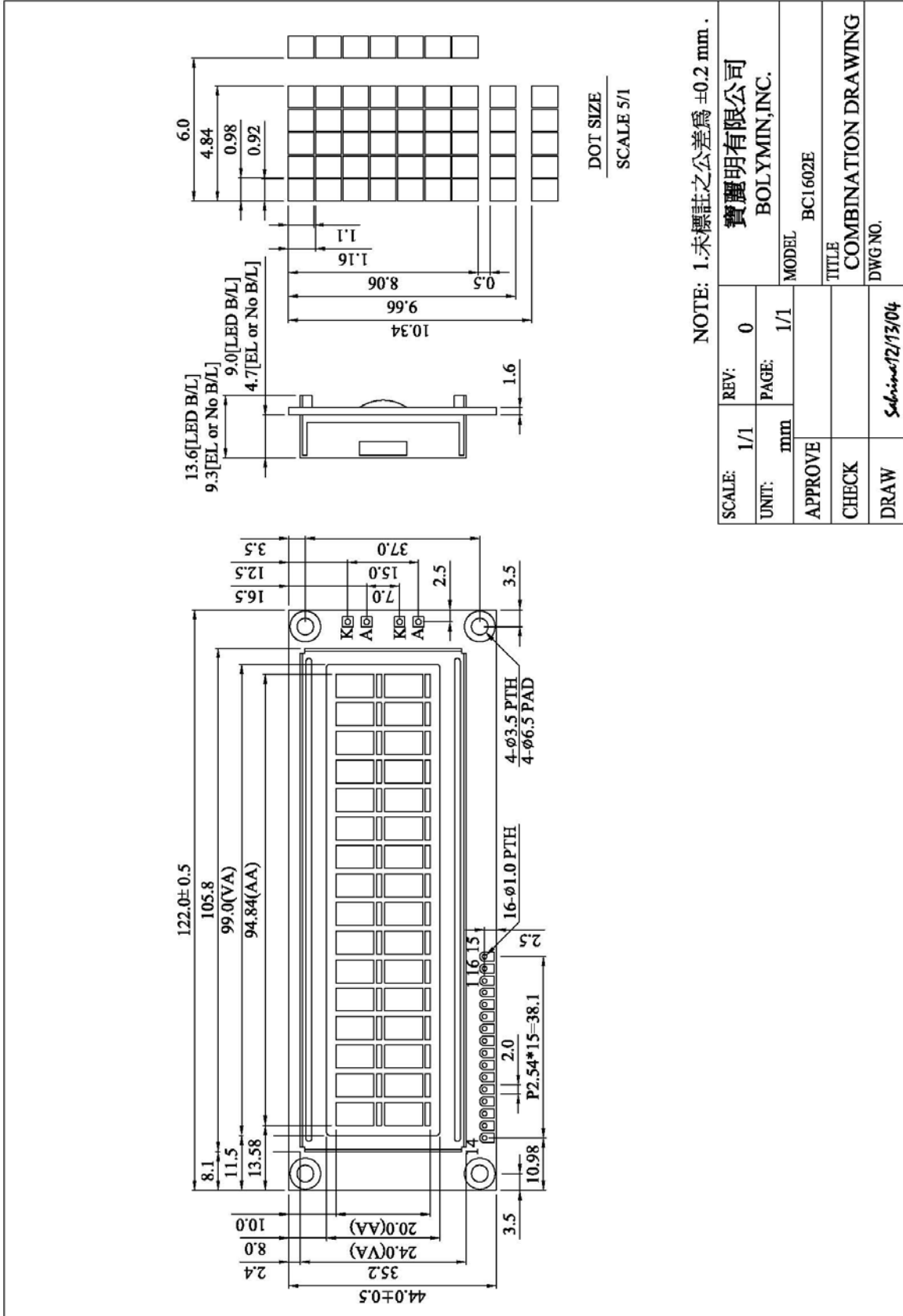



**12-2. KS0066 controller data**

12-2.1 Function description

The LCD display Module is built in a LSI controller, the controller has two 8-bit registers, an instruction register (IR) and a data register (DR).

The IR stores instruction codes, such as display clear and cursor shift, and address information for display data RAM (DDRAM) and character generator (CGRAM). The IR can only be written from the MPU. The DR temporarily stores data to be written or read from DDRAM or CGRAM. When address information is written into the IR, then data is stored into the DR from DDRAM or CGRAM. By the register selector (RS) signal, these two registers can be selected.

| RS | R/W | Operation   |
|----|-----|---|
| 0  | 0   | IR write as an internal operation (display clear, etc.) |
| 0  | 1   | Read busy flag (DB7) and address counter (DB0 to DB7)   |
| 1  | 0   | Write data to DDRAM or CGRAM (DR to DDRAM or CGRAM)     |
| 1  | 1   | Read data from DDRAM or CGRAM (DDRAM or CGRAM to DR)    |

Busy Flag (BF)

When the busy flag is 1, the controller LSI is in the internal operation mode, and the next instruction will not be accepted. When RS=0 and R/W=1, the busy flag is output to DB7. The next instruction must be written after ensuring that the busy flag is 0.

Address Counter (AC)

The address counter (AC) assigns addresses to both DDRAM and CGRAM

Display Data RAM (DDRAM)

This DDRAM is used to store the display data represented in 8-bit character codes. Its extended capacity is 80x8 bits or 80 characters. Below figure is the relationship between DDRAM addresses and positions on the liquid crystal display.

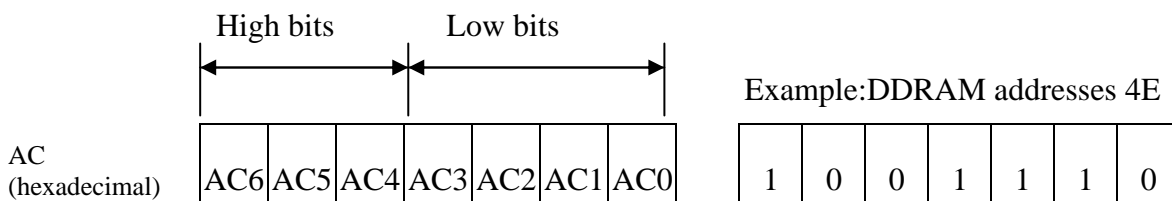



DDRAM Address

Display position DDRAM address

1 2 3 4 5 6 7 8 9 10 11 12 13 14 15 16

|    |    |    |    |    |    |    |    |    |    |    |    |    |    |    |    |
|----|----|----|----|----|----|----|----|----|----|----|----|----|----|----|----|
| 00 | 01 | 02 | 03 | 04 | 05 | 06 | 07 | 08 | 09 | 0A | 0B | 0C | 0D | 0E | 0F |
| 40 | 41 | 42 | 43 | 44 | 45 | 46 | 47 | 48 | 49 | 4A | 4B | 4C | 4D | 4E | 4F |

Example: 2-Line by 16-Character Display

Character Generator ROM (CGROM)

The CGROM generate 5×8 dot or 5×10 dot character patterns from 8-bit character codes. See Table 2.

Character Generator RAM (CGRAM)

In CGRAM, the user can rewrite character by program. For 5×8 dots, eight character patterns can be written, and for 5×10 dots, four character patterns can be written.

Write into DDRAM the character code at the addresses shown as the left column of table 1. To show the character patterns stored in CGRAM.



Relationship between CGRAM Addresses, Character Codes (DDRAM) and Character Patterns (CGRAM Data)

For 5 \* 8 dot character patterns

| Character Codes ( DDRAM data ) |   |   |   |     |   |   |   | CGRAM Address |  |  |     |  |  | Character Patterns ( CGRAM data ) |       |  |   |     |  |   |  |  |                        |                |  |
|--------------------------------|---|---|---|-----|---|---|---|---------------|--|--|-----|--|--|-----------------------------------|-------|--|---|-----|--|---|--|--|------------------------|----------------|--|
| 7                              | 6 | 5 | 4 | 3   | 2 | 1 | 0 | 5             |  |  | 4   |  |  | 3                                 |       |  | 2 |     |  | 1 |  |  | 0                      |                |  |
| High                           |   |   |   | Low |   |   |   | High          |  |  | Low |  |  | High                              |       |  |   | Low |  |   |  |  |                        |                |  |
| 0 0 0 0 * 0 0 0                |   |   |   |     |   |   |   | 0 0 0         |  |  |     |  |  | 0 0 0                             | * * * |  |   |     |  |   |  |  | Character pattern( 1 ) |                |  |
|                                |   |   |   |     |   |   |   |               |  |  |     |  |  | 0 0 1                             | * * * |  |   |     |  |   |  |  | 0 0 0                  | Cursor pattern |  |
|                                |   |   |   |     |   |   |   |               |  |  |     |  |  | 0 1 0                             | * * * |  |   |     |  |   |  |  | 0 0 0                  |                |  |
|                                |   |   |   |     |   |   |   |               |  |  |     |  |  | 0 1 1                             | * * * |  |   |     |  |   |  |  | 0 0 0                  |                |  |
|                                |   |   |   |     |   |   |   |               |  |  |     |  |  | 1 0 0                             | * * * |  |   |     |  |   |  |  | 0 0 0                  |                |  |
|                                |   |   |   |     |   |   |   |               |  |  |     |  |  | 1 0 1                             | * * * |  |   |     |  |   |  |  | 0 0 0                  |                |  |
|                                |   |   |   |     |   |   |   |               |  |  |     |  |  | 1 1 0                             | * * * |  |   |     |  |   |  |  | 0 0 0                  |                |  |
|                                |   |   |   |     |   |   |   |               |  |  |     |  |  | 1 1 1                             | * * * |  |   |     |  |   |  |  | 0 0 0                  |                |  |
|                                |   |   |   |     |   |   |   |               |  |  |     |  |  | 0 0 0                             | * * * |  |   |     |  |   |  |  | 0 0 0                  |                |  |
|                                |   |   |   |     |   |   |   |               |  |  |     |  |  | 0 0 1                             | * * * |  |   |     |  |   |  |  | 0 0 0                  |                |  |
| 0 0 0 0 * 0 0 1                |   |   |   |     |   |   |   | 0 0 1         |  |  |     |  |  | 0 1 0                             | * * * |  |   |     |  |   |  |  | Character pattern( 2 ) |                |  |
|                                |   |   |   |     |   |   |   |               |  |  |     |  |  | 0 1 1                             | * * * |  |   |     |  |   |  |  | 0 0 0                  |                |  |
|                                |   |   |   |     |   |   |   |               |  |  |     |  |  | 1 0 0                             | * * * |  |   |     |  |   |  |  | 0 0 0                  |                |  |
|                                |   |   |   |     |   |   |   |               |  |  |     |  |  | 1 0 1                             | * * * |  |   |     |  |   |  |  | 0 0 0                  |                |  |
|                                |   |   |   |     |   |   |   |               |  |  |     |  |  | 1 1 0                             | * * * |  |   |     |  |   |  |  | Cursor pattern         |                |  |
|                                |   |   |   |     |   |   |   |               |  |  |     |  |  | 1 1 1                             | * * * |  |   |     |  |   |  |  | 0 0 0                  |                |  |
|                                |   |   |   |     |   |   |   |               |  |  |     |  |  | 0 0 0                             | * * * |  |   |     |  |   |  |  | 0 0 0                  |                |  |
|                                |   |   |   |     |   |   |   |               |  |  |     |  |  | 0 0 1                             | * * * |  |   |     |  |   |  |  | 0 0 0                  |                |  |
| 0 0 0 0 * 1 1 1                |   |   |   |     |   |   |   | 1 1 1         |  |  |     |  |  | 1 0 0                             | * * * |  |   |     |  |   |  |  |                        |                |  |
|                                |   |   |   |     |   |   |   |               |  |  |     |  |  | 1 0 1                             | * * * |  |   |     |  |   |  |  |                        |                |  |
|                                |   |   |   |     |   |   |   |               |  |  |     |  |  | 1 1 0                             | * * * |  |   |     |  |   |  |  |                        |                |  |
|                                |   |   |   |     |   |   |   |               |  |  |     |  |  | 1 1 1                             | * * * |  |   |     |  |   |  |  |                        |                |  |

For 5 \* 10 dot character patterns

| Character Codes ( DDRAM data ) |   |   |   |   |     |   |   |   |  | CGRAM Address |   |  |     |   |  | Character Patterns ( CGRAM data ) |       |  |  |   |     |  |   |  |  |  |  |                   |  |
|--------------------------------|---|---|---|---|-----|---|---|---|--|---------------|---|--|-----|---|--|-----------------------------------|-------|--|--|---|-----|--|---|--|--|--|--|-------------------|--|
| 7                              | 6 | 5 | 4 | 3 | 2   | 1 | 0 | 5 |  |               | 4 |  |     | 3 |  |                                   | 2     |  |  | 1 |     |  | 0 |  |  |  |  |                   |  |
| High                           |   |   |   |   | Low |   |   |   |  | High          |   |  | Low |   |  | High                              |       |  |  |   | Low |  |   |  |  |  |  |                   |  |
| 0 0 0 0 * 0 0 0                |   |   |   |   |     |   |   |   |  | 0 0           |   |  |     |   |  | 0 0 0 0                           | * * * |  |  |   |     |  |   |  |  |  |  | Character pattern |  |
|                                |   |   |   |   |     |   |   |   |  |               |   |  |     |   |  | 0 0 0 1                           | * * * |  |  |   |     |  |   |  |  |  |  | 0 0 0 0           |  |
|                                |   |   |   |   |     |   |   |   |  |               |   |  |     |   |  | 0 0 1 0                           | * * * |  |  |   |     |  |   |  |  |  |  | 0 0 0 0           |  |
|                                |   |   |   |   |     |   |   |   |  |               |   |  |     |   |  | 0 0 1 1                           | * * * |  |  |   |     |  |   |  |  |  |  | 0 0 0 0           |  |
|                                |   |   |   |   |     |   |   |   |  |               |   |  |     |   |  | 0 1 0 0                           | * * * |  |  |   |     |  |   |  |  |  |  | 0 0 0 0           |  |
|                                |   |   |   |   |     |   |   |   |  |               |   |  |     |   |  | 0 1 0 1                           | * * * |  |  |   |     |  |   |  |  |  |  | 0 0 0 0           |  |
|                                |   |   |   |   |     |   |   |   |  |               |   |  |     |   |  | 0 1 1 0                           | * * * |  |  |   |     |  |   |  |  |  |  | 0 0 0 0           |  |
|                                |   |   |   |   |     |   |   |   |  |               |   |  |     |   |  | 0 1 1 1                           | * * * |  |  |   |     |  |   |  |  |  |  | 0 0 0 0           |  |
|                                |   |   |   |   |     |   |   |   |  |               |   |  |     |   |  | 1 0 0 0                           | * * * |  |  |   |     |  |   |  |  |  |  | 0 0 0 0           |  |
|                                |   |   |   |   |     |   |   |   |  |               |   |  |     |   |  | 1 0 0 1                           | * * * |  |  |   |     |  |   |  |  |  |  | 0 0 0 0           |  |
|                                |   |   |   |   |     |   |   |   |  |               |   |  |     |   |  | 1 0 1 0                           | * * * |  |  |   |     |  |   |  |  |  |  | Cursor pattern    |  |
|                                |   |   |   |   |     |   |   |   |  |               |   |  |     |   |  | 1 0 1 0                           | * * * |  |  |   |     |  |   |  |  |  |  | 0 0 0 0           |  |
|                                |   |   |   |   |     |   |   |   |  |               |   |  |     |   |  | 1 1 1 1                           | * * * |  |  |   |     |  |   |  |  |  |  |                   |  |
|                                |   |   |   |   |     |   |   |   |  |               |   |  |     |   |  | 1 1 1 1                           | * * * |  |  |   |     |  |   |  |  |  |  | * * * * *         |  |

■ : " High "



Code E: English - European Font

| Upper<br>4 bit<br>Lower<br>4 bit | LLLL               | LLLH | LLHL | LLHH | LHLL | LHLH | LHHL | LHHH | HLLL | HLLH | HLHL | HLHH | HHLL | HHLH | HHHL | HHHH |
|----------------------------------|--------------------|------|------|------|------|------|------|------|------|------|------|------|------|------|------|------|
| LLLL                             | CG<br>RAM<br>( 1 ) |      |      |      |      |      |      |      |      |      |      |      |      |      |      |      |
| LLLH                             | CG<br>RAM<br>( 2 ) |      |      |      |      |      |      |      |      |      |      |      |      |      |      |      |
| LLHL                             | CG<br>RAM<br>( 3 ) |      |      |      |      |      |      |      |      |      |      |      |      |      |      |      |
| LLHH                             | CG<br>RAM<br>( 4 ) |      |      |      |      |      |      |      |      |      |      |      |      |      |      |      |
| LHLL                             | CG<br>RAM<br>( 5 ) |      |      |      |      |      |      |      |      |      |      |      |      |      |      |      |
| LHLH                             | CG<br>RAM<br>( 6 ) |      |      |      |      |      |      |      |      |      |      |      |      |      |      |      |
| LHHL                             | CG<br>RAM<br>( 7 ) |      |      |      |      |      |      |      |      |      |      |      |      |      |      |      |
| LHHH                             | CG<br>RAM<br>( 8 ) |      |      |      |      |      |      |      |      |      |      |      |      |      |      |      |
| HLLL                             | CG<br>RAM<br>( 1 ) |      |      |      |      |      |      |      |      |      |      |      |      |      |      |      |
| HLLH                             | CG<br>RAM<br>( 2 ) |      |      |      |      |      |      |      |      |      |      |      |      |      |      |      |
| HLHL                             | CG<br>RAM<br>( 3 ) |      |      |      |      |      |      |      |      |      |      |      |      |      |      |      |
| HLHH                             | CG<br>RAM<br>( 4 ) |      |      |      |      |      |      |      |      |      |      |      |      |      |      |      |
| HHLL                             | CG<br>RAM<br>( 5 ) |      |      |      |      |      |      |      |      |      |      |      |      |      |      |      |
| HHLH                             | CG<br>RAM<br>( 6 ) |      |      |      |      |      |      |      |      |      |      |      |      |      |      |      |
| HHHL                             | CG<br>RAM<br>( 7 ) |      |      |      |      |      |      |      |      |      |      |      |      |      |      |      |
| HHHH                             | CG<br>RAM<br>( 8 ) |      |      |      |      |      |      |      |      |      |      |      |      |      |      |      |



## 12-2.3 Instruction table

| Instruction                | Instruction Code |     |     |     |     |     |     |     |     |     | Description | Execution time<br>(fosc=270Khz)  |            |
|----------------------------|------------------|-----|-----|-----|-----|-----|-----|-----|-----|-----|-------------|--|------------|
|                            | RS               | R/W | DB7 | DB6 | DB5 | DB4 | DB3 | DB2 | DB1 | DB0 |             |  |            |
| Clear Display              | 0                | 0   | 0   | 0   | 0   | 0   | 0   | 0   | 0   | 0   | 1           | Write "00H" to DDRAM and set DDRAM address to "00H" from AC  | 1.53ms     |
| Return Home                | 0                | 0   | 0   | 0   | 0   | 0   | 0   | 0   | 0   | 1   | —           | Set DDRAM address to "00H" from AC and return cursor to its original position if shifted. The contents of DDRAM are not changed.   | 1.53ms     |
| Entry Mode Set             | 0                | 0   | 0   | 0   | 0   | 0   | 0   | 0   | 1   | I/D | SH          | Assign cursor moving direction and enable the shift of entire display.   | 39 $\mu$ s |
| Display ON/OFF Control     | 0                | 0   | 0   | 0   | 0   | 0   | 0   | 1   | D   | C   | B           | Set display (D), cursor (C), and blinking of cursor (B) on/off control bit.  | 39 $\mu$ s |
| Cursor or Display Shift    | 0                | 0   | 0   | 0   | 0   | 0   | 1   | S/C | R/L | —   | —           | Set cursor moving and display shift control bit, and the direction, without changing of DDRAM data.                                | 39 $\mu$ s |
| Function Set               | 0                | 0   | 0   | 0   | 0   | 1   | DL  | N   | F   | —   | —           | Set interface data length (DL:8-bit/4-bit), numbers of display line (N:2-line/1-line)and, display font type (F:5×11 dots/5×8 dots) | 39 $\mu$ s |
| Set CGRAM Address          | 0                | 0   | 0   | 1   | AC5 | AC4 | AC3 | AC2 | AC1 | AC0 |             | Set CGRAM address in address counter.  | 39 $\mu$ s |
| Set DDRAM Address          | 0                | 0   | 1   | AC6 | AC5 | AC4 | AC3 | AC2 | AC1 | AC0 |             | Set DDRAM address in address counter.  | 39 $\mu$ s |
| Read Busy Flag and Address | 0                | 1   | BF  | AC6 | AC5 | AC4 | AC3 | AC2 | AC1 | AC0 |             | Whether during internal operation or not can be known by reading BF. The contents of address counter can also be read.             | 0 $\mu$ s  |
| Write Data to RAM          | 1                | 0   | D7  | D6  | D5  | D4  | D3  | D2  | D1  | D0  |             | Write data into internal RAM (DDRAM/CGRAM).  | 43 $\mu$ s |
| Read Data from RAM         | 1                | 1   | D7  | D6  | D5  | D4  | D3  | D2  | D1  | D0  |             | Read data from internal RAM (DDRAM/CGRAM).   | 43 $\mu$ s |

\* "—" : don't care



## 12-2.4 Timing characteristics

### 12-2.4.1 Write Operation

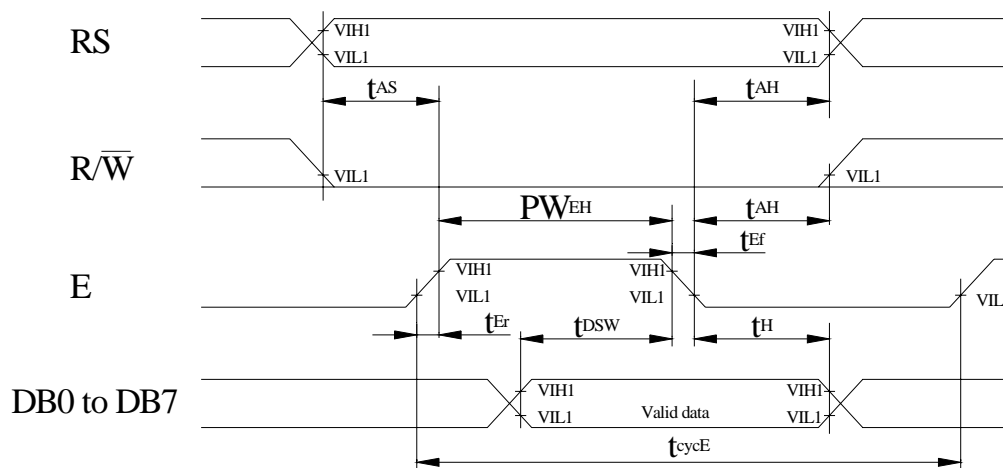

$T_a=25^{\circ}\text{C}, V_{dd}=5.0\pm 0.5\text{V}$

| Item                               | Symbol           | Min | Typ | Max | Unit |
|------------------------------------|------------------|-----|-----|-----|------|
| Enable cycle time                  | $t_{cycE}$       | 500 | —   | —   | ns   |
| Enable pulse width (high level)    | $PW_{EH}$        | 230 | —   | —   | ns   |
| Enable rise/fall time              | $t_{Er}, t_{Ef}$ | —   | —   | 20  | ns   |
| Address set-up time (RS, R/W to E) | $t_{AS}$         | 40  | —   | —   | ns   |
| Address hold time                  | $t_{AH}$         | 10  | —   | —   | ns   |
| Data set-up time                   | $t_{DSW}$        | 80  | —   | —   | ns   |
| Data hold time                     | $t_H$            | 10  | —   | —   | ns   |



### 12-2.4.2 Read Operation

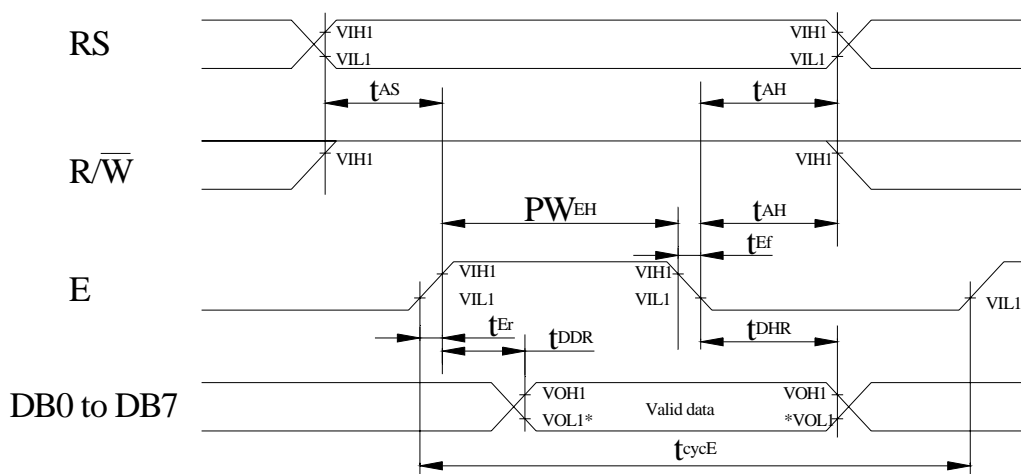

NOTE: \*VOL1 is assumed to be 0.8V at 2 MHz operation.

$T_a=25^{\circ}C, V_{dd}=5.0\pm 0.5V$

| Item                               | Symbol           | Min | Typ | Max | Unit |
|------------------------------------|------------------|-----|-----|-----|------|
| Enable cycle time                  | $t_{cycE}$       | 500 | —   | —   | ns   |
| Enable pulse width (high level)    | $PW_{EH}$        | 230 | —   | —   | ns   |
| Enable rise/fall time              | $t_{Er}, t_{Df}$ | —   | —   | 20  | ns   |
| Address set-up time (RS, R/W to E) | $t_{AS}$         | 40  | —   | —   | ns   |
| Address hold time                  | $t_{AH}$         | 10  | —   | —   | ns   |
| Data delay time                    | $t_{DDR}$        | —   | —   | 100 | ns   |
| Data hold time                     | $t_{DHR}$        | 5   | —   | —   | ns   |



## 12-2.5 Initializing soft ware of LCM

### 12-2.5.1 8-bit interface

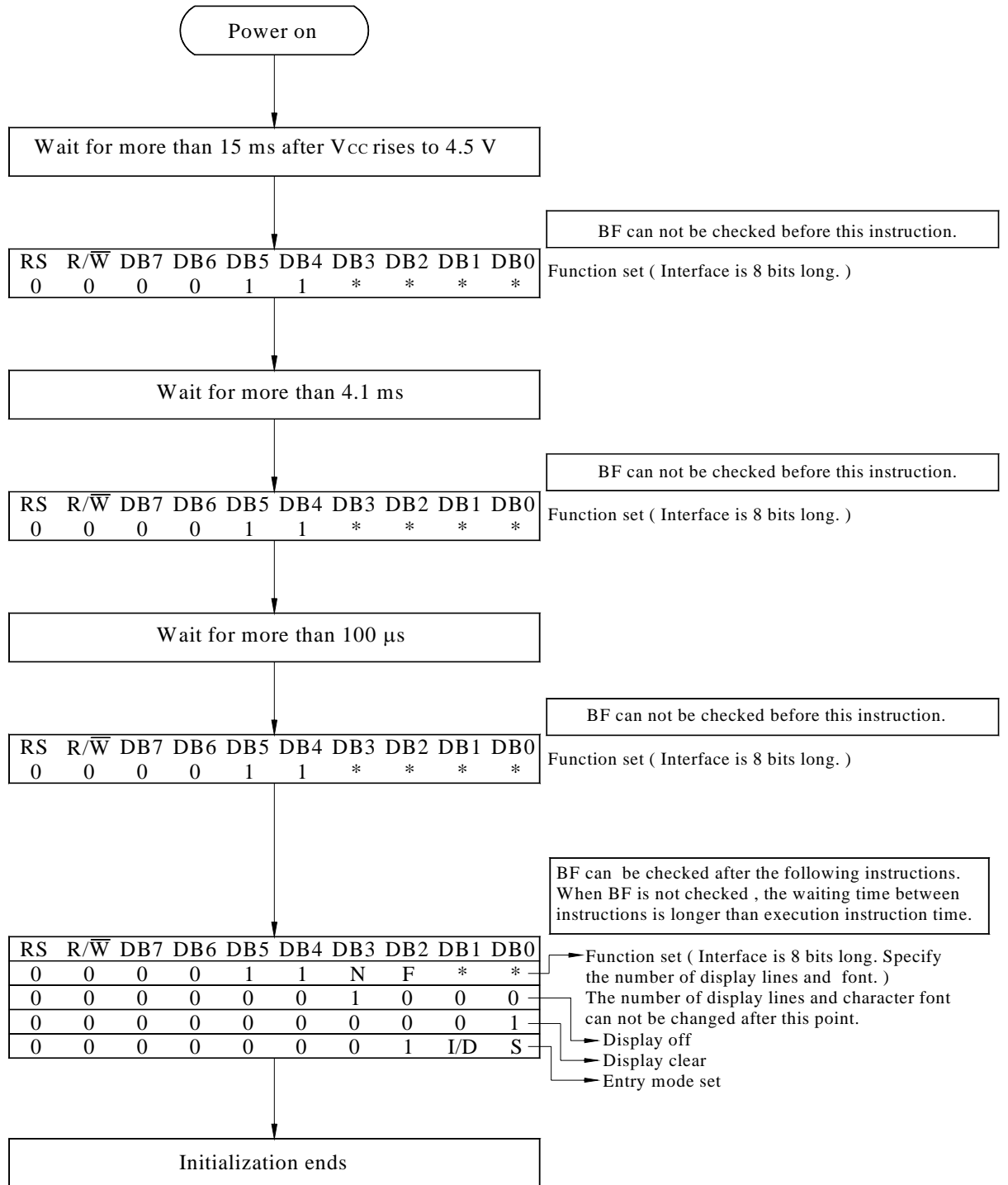

8-Bit Ineterface



12-2.5.2 4-bit interface

