

**TOP SMD LED**

# **JZ-S35280SY-CT**

## **DATA SHEET**

**DOCUMENT NO.:** WI-RD-SDS-S35280SY-CT  
**RELEASE DATE:** 2007- 04-21  
**VERSION:** A/0

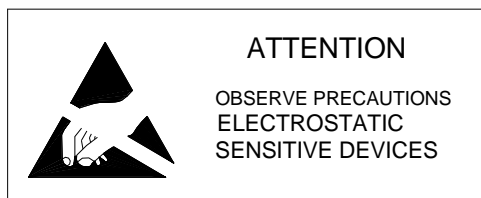

## PART NO.: JZ-S35280SY-CT

### Features:

- LENS COLOR : WATER CLEAR
- EMITTING COLOR : YELLOW
- VIEWING ANGLE : 120°
- ROHS AND CE COMPLIANT
- LOW POWER CONSUMPTION
- WIDE VIEWING ANGLE.
- VARIOUS COLORS AVAILABLE
- PACKAGE: 1500PCS/REEL

### Application:

Indicator  
Back-light  
Decoration  
others

### Description

The Yellow source color devices are made with AlGaInP Light Emitting Diode.

### Package Dimensions

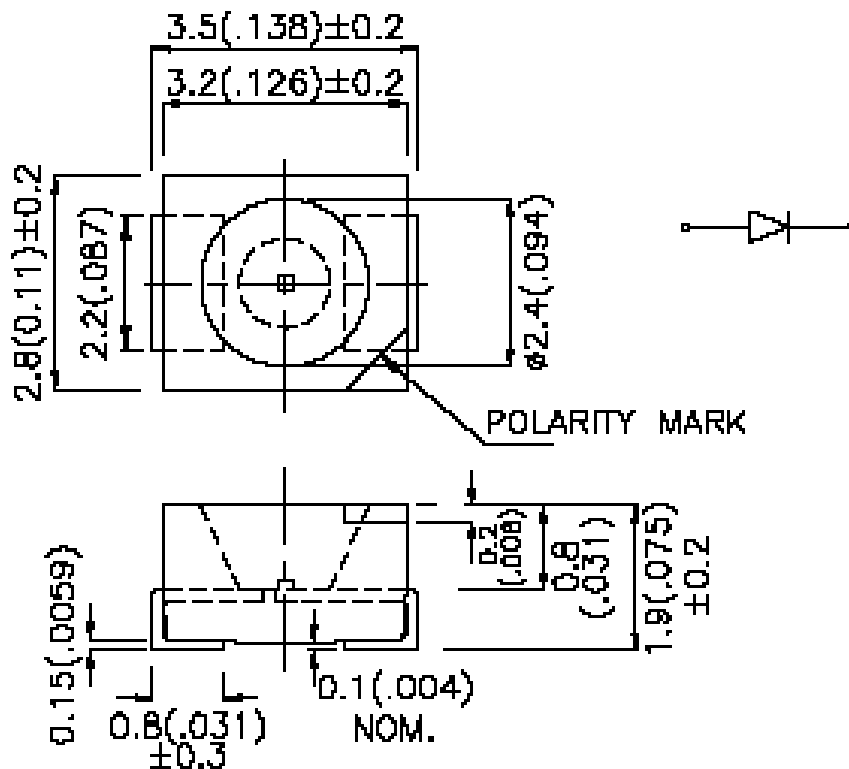

### Notes:

1. All dimension are in millimeters and(Inch)tolerance is  $\pm 0.1$  ( 0.004" ) unless otherwise noted.
- 2.Specifications are subject to change without notice.

## PART NO.:JZ-S35280SY-CT

### Absolute Maximum Rating at=Ta=25°C

Power Dissipation	100	mW
Peak Forward Current (1/10 Duty Cycle, 0.1ms Pulse Width)	120	mA
Forward Current	25	mA
Operating Temperature Range	-30°C to +85°C	
Storage Temperature Range	-40°C to +100°C	

### Electrical /Optical Characteristics at Ta=25°C

Description	Symbol	Conditions	Min.	Typ.	Max.	Unit
Forward Voltage	V <sub>F</sub>	I <sub>F</sub> =20mA	1.8	2.0	2.4	V
Reverse Current	I <sub>R</sub>	V <sub>R</sub> =5V	/	/	10	μA
Dominant Wavelength	λ <sub>D</sub>	I <sub>F</sub> =20mA	585	588	/	nm
Luminous Intensity	I <sub>v</sub>	I <sub>F</sub> =20mA	150	220	290	mcd
Half V-angle	2θ <sub>1/2</sub>	I <sub>F</sub> =20mA	/	120	/	deg

1. V<sub>f</sub> maximum tolerance for each bin Include is ±0.1V.
2. I<sub>v</sub> maximum tolerance for each bin Include is ±15%.
3. λ<sub>D</sub> maximum tolerance for each bin Include is ±1nm.

**PART NO.:JZ-S35280SY-CT**

**Typical Optical-Electronic Characteristic Curves**

$I_f$ (mA)

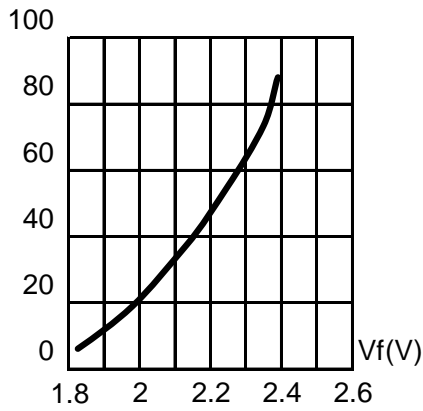

CURRENT VS. FORWARD VOLTAGE.

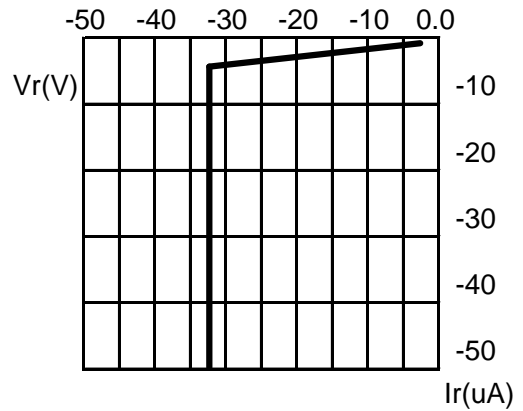

CURRENT VS. REVERSE VOLTAGE.

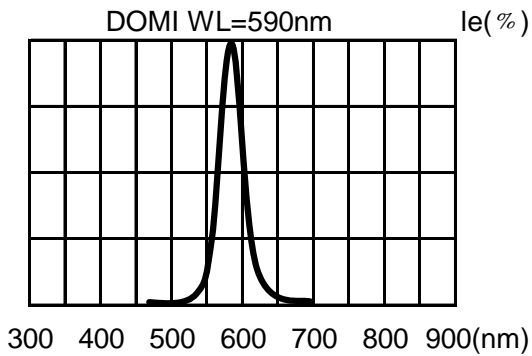
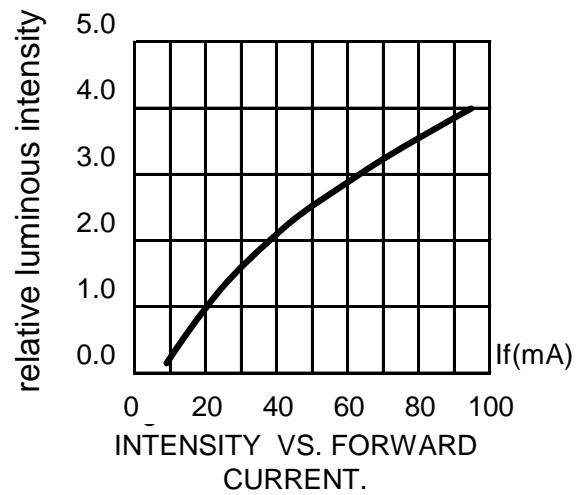

Fig.4 RELATIVE LUMINOUS INTENSITY VS. WAVELENGTH.



INTENSITY VS. FORWARD CURRENT.

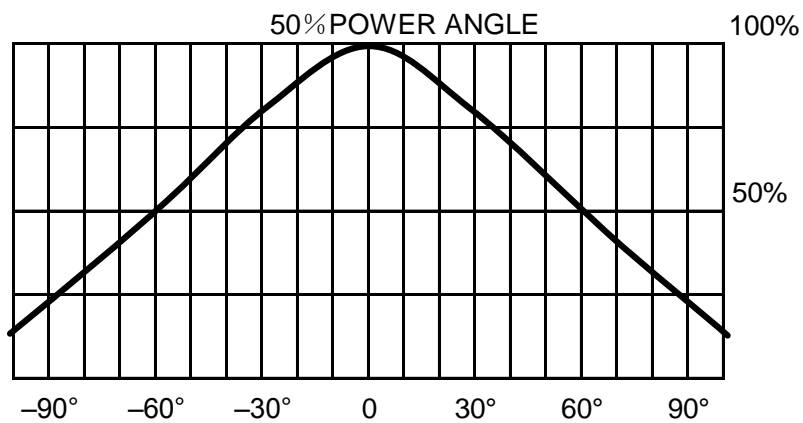
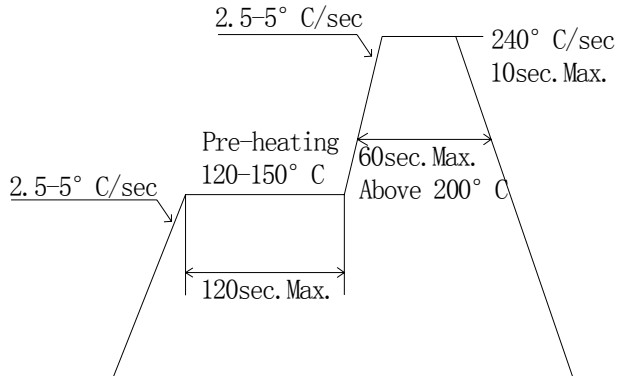

Fig.5 FAR FIELD PATTERN

## SMT Reflow Soldering Instructions

Number of reflow process shall be less than 2 times and cooling process to normal temperature is required between first and second soldering process.

### 1. Lead Solder



### 2. Lead-free Solder

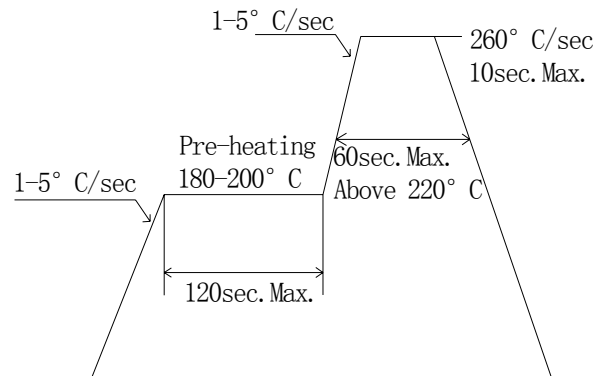

## Recommended Soldering Pattern

<Units:mm>

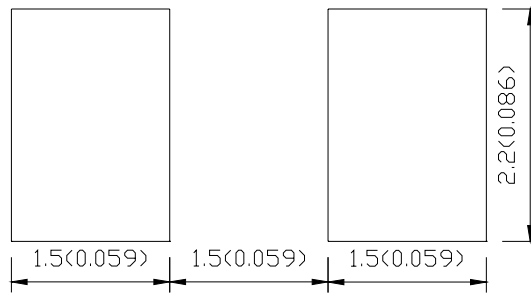

## Tape Specifications

<Units:mm>

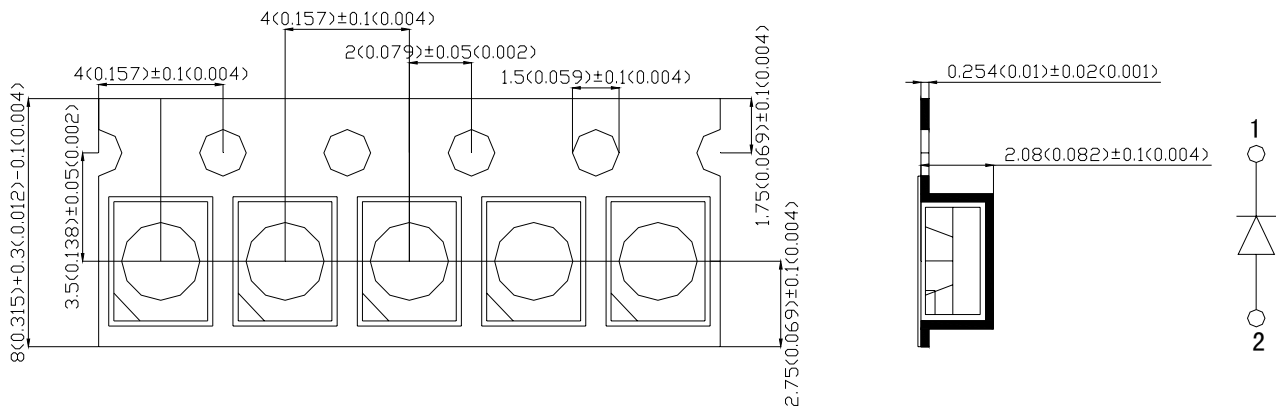

## **CAUTIONS:**

### **Storage time**

1. The operation of Temperatures and RH are: 5°C~35°C, RH60%.
2. Once the package is opened, the products should be used within a week.  
Otherwise, they should be kept in a damp proof box with desiccating agent.  
Considering the tape life, we suggest our customers to use our products within a year(from production date).
3. If opened more than one week in an atmosphere 5°C~ 35°C, RH60%, they should be treated at 60°C±5 °Cfor 15hours.

### **Cleaning**

Use alcohol-based cleaning solvents such as isopropyl alcohol to clean the LED.

### **ESD(Electrostatic Discharge)**

Static Electricity or power surge will damage the LED. Use of a conductive wrist band or anti-electrosatic glove is recommended when handing these LED. All devices, equipment and machinery must be properly grounded.

**(1)Test Items And Results**

Test Item	Standard Test Method	Test Conditions	Note	Number of Damaged
Resistance to Soldering Heat	JEITA ED-4701 300 302	Tsld=260± 5°C,10sec. 3mm from the base of the epoxy bulb	1time	0/100
Solderability	JEITA ED-4701 300 303	Tsld=235+ 5°C,5sec. (using flux)	1time over 95%	0/100
Thermal Shock	JEITA ED-4701 300 307	-40°C/15min.~100°C/15min.	100cycles	0/100
Temperature Cycle	JEITA ED-4701 100 105	-40°C/30min.~25°C/5min. ~100°C/30min.~25°C/5min.	100cycles	0/100
Moisture Resistance Cyclic	JEITA ED-4701 200 203	25°C~65°C~-10°C 90%RH 24hrs./1cycle	10cycles	0/100
Terminal Strength(bending test)	JEITA ED-4701 400 401	Load 5N(0.5kgf) 0°~90°~0°bend 2 times	No noticeable damage	0/100
Terminal Strength(pull test)	JEITA ED-4701 400 401	Load 10N(1kgf)10±1sec.	No noticeable damage	0/100
High temperature Storage	JEITA ED-4701 200 201	Ta=100°C	1000hrs.	0/100
Temperature Humidity Storage	JEITA ED-4701 100 103	Ta=60°C,RH=90%	1000hrs.	0/100
Low Temperature Storage	JEITA ED-4701 200 202	Ta=-40°C	1000hrs.	0/100
Steady state Operating Life		Ta=25°C,IF=20mA	1000hrs.	0/100
Steady State Operating Life of High Humidity Heat		60°C,RH=90%,IF=20mA	500hrs.	0/100
Steady State Operating Life of Low Temperature		Ta=-30°C,IF=20mA	1000hrs.	0/100
Resistance to UV Beam		365nm/75W/mm	192hrs.	0/100

**(2)Criteria For Judging The Damage**

Item	Symbol	Test Conditions	Criteria for Judgement	
			Min.	Max.
Forward Voltage	Vf	IF=20mA	-	U.S.L.*) x 1.1
Reverse Current	Ir	VR=5V	-	U.S.L.*) x 2.0
Luminous Intensity	Iv	IF=20mA	L.S.L.**)	x 0.7
*)U.S.L.:Upper Standard Level			**)L.S.L.:Lower Standard Level	