

ROUND 3MM LED LAMP [3MM 圆头二极管]

JZL-PG304C-A5

DATA SHEET

规格书

DOCUMENT NO.: WI-RD-LDS-PG304C-A5
文件编号

RELEASE DATE: 2007- 12-25
制作日期

VERSION: A/0
版次



ATTENTION

OBSERVE PRECAUTIONS
ELECTROSTATIC
SENSITIVE DEVICES

PART NO [产品型号].: JZL-PG304C-A5

Features:

- 3mm Round lamp
- Lens color: Water Clear
- Emitting color: Green
- viewing angle: 15°
- Leads with stand-offs: NO
- RoHS compliant

Application:

- Indicator
- Decoration
- keyboard
- others

描述:

- 3mm 圆灯
- 外观胶色: 无色透明
- 发光颜色: 绿光
- 发光角度: 15°
- 引脚有无卡位: 无
- 符合 RoHS 标准

适用于:

- 指示器
- 装饰
- 照明
- 其它

Package Dimensions [产品外观尺寸]

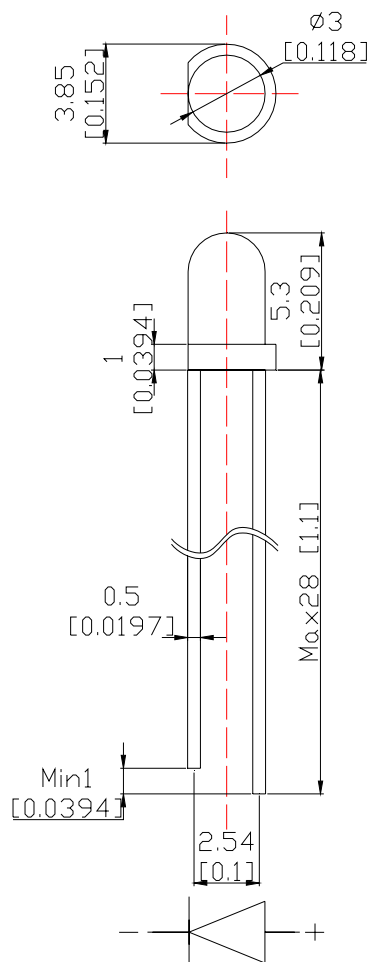

Notes [备注]:

1. All dimension are in millimeters and(Inch)tolerance is ± 0.25 mm unless otherwise noted.
未注明的公差尺寸以毫米或英寸为单位, 不超过 ± 0.25 mm.
2. Specifications are subject to change without notice.
· 没有得到通知时规格书我司有权作任何修改。

PART NO[产品型号].: JZL-PG304C-A5

Absolute Maximum Rating at Ta=25°C

[在 25°C 环境下最大额定值]

Power Dissipation [最大功率]	120	mW
Peak Forward Current [正向峰值电流] (1/10 Duty Cycle, 0.1ms Pulse Width)	120	mA
Forward Current [正向电流]	25	mA
Operating Temperature Range [工作温度]	-30°C to +85°C	
Storage Temperature Range [储存温度]	-40°C to +100°C	
Lead Soldering Temperature [3mm From Body] [焊接温度]	260°C for 3 Seconds	

Electrical /Optical Characteristics at Ta=25°C

[在 25°C 环境下电性/光学特性]

Description 描述	Symbol 符号	Conditions 条件	Min. 最小值	Typ. 典型值	Max. 最大值	Unit 单位
Forward Voltage 正向电压	VF	IF=20mA	2.8	3.2	4.0	V
Reverse Current 反向电流	IR	VR=5V	/	/	10	μA
Dominant Wavelength 主波长	λD	IF=20mA	/	525	/	
Luminous Intensity 发光亮度	Iv	IF=20mA	/	9000	/	mcd
Half V-angle 发光角度	2θ1/2H-H	IF=20mA	/	15	/	deg
	2θ1/2V-V	IF=20mA	/	/	/	deg

1. Vf maximum tolerance for each bin include is ±0.1V.
(每个 BIN 的电压最大误差 ±0.1V)
2. Iv maximum tolerance for each bin Include is ±15%.
(每个 BIN 的亮度最大误差 ±15%)
3. λD maximum tolerance for each bin Include is ±1nm.
(每个 BIN 的波长最大误差 ±1nm)

Typical Optical-Electronic Characteristic Curves

典型光电特征曲线图

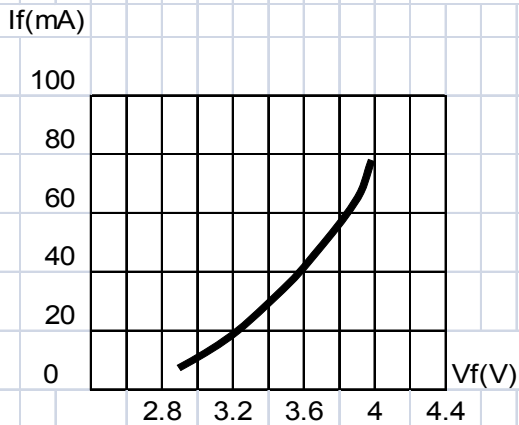

Fig.1 FORWARD CURRENT VS. FORWARD VOLTAGE
电压与电流关系曲线图

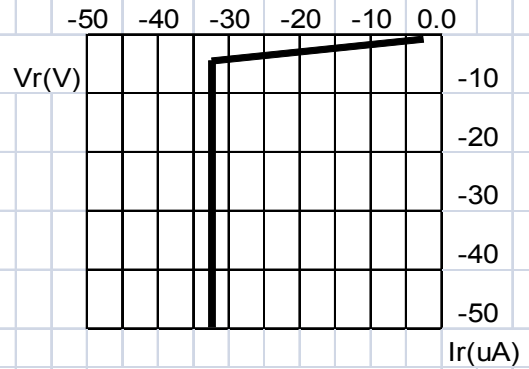

Fig.2 REVERSE CURRENT VS. REVERSE VOLTAGE.
反相电流与反相电压关系曲线图

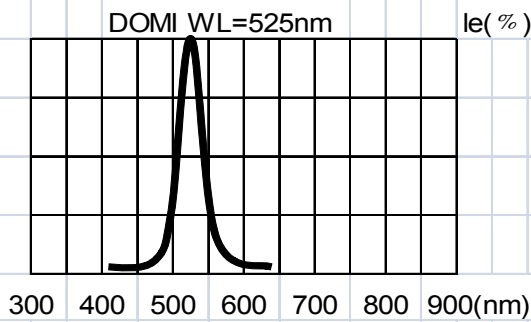

Fig.4 RELATIVE LUMINOUS INTENSITY VS. WAVELENGTH.
亮度与波长关系曲线图

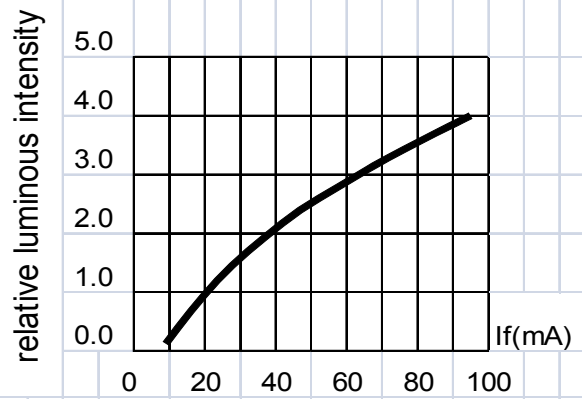

Fig.3 RELATIVE LUMINOUS INTENSITY VS. FORWARD CURRENT
相对发光亮度与正向电流关系曲线图

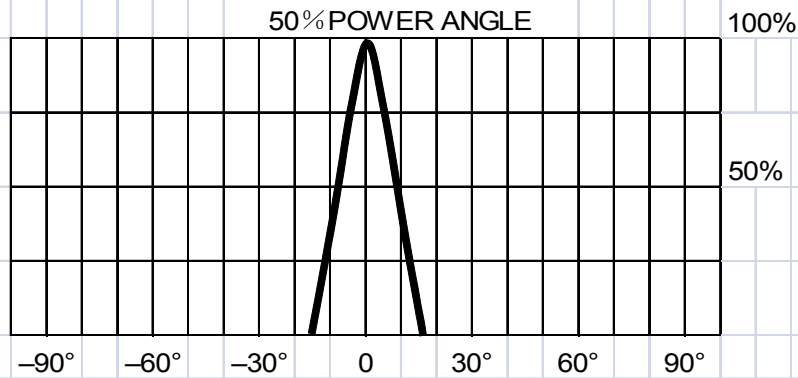

Fig.5 FAR FIELD PATTERN
发光曲线模式

CAUTIONS:

Storage time

1. The operation of Temperatures and RH are: 5°C~35°C, RH60%.
2. Once the package is opened, the products should be used within a week. Otherwise, they should be kept in a damp proof box with desiccating agent. Considering the Led life, we suggest our customers to use our products within a year(from production date).
3. If opened more than one week in an atmosphere 5°C~ 35°C, RH60%, they should be treated at 60°C±5 °Cfor 15hours.

Cleaning

Use alcohol-based cleaning solvents such as isopropyl alcohol to clean the LED.

ESD(Electrostatic Discharge)

Static Electricity or power surge will damage the LED. Use of a conductive wrist band or anti-electrosatic glove is recommended when handing these LED. All devices, equipment and machinery must be properly grounded

注意:

储藏时间

1. 温度和湿度条件为: 5 °C-35 °C, 60%RH.
2. 包装被打开后, 产品应该在一个星期内用完, 否则, 应该以原包装的样式保存在防潮柜中;
考虑使用的寿命, 我们建议客户在一年内将产品使用完(从制造日期起);
3. 如果在大气温度 5°C-35 °C、湿度 60% RH 的环境中打开超过一个星期, 则应该用 60 °C ±5°C 的温度处理 15 小时后再使用.

清洁

使用酒精或以酒精为主的清洁溶剂清理该产品。

ESD(静电的防范)

静电会损坏发光二极管, 拿发光二极管的过程中请使用防静电手腕或戴防备静电手套. 所有装置、仪器和机器必须完好接地.

Reliability Test:

(1)Test Items And Results

Test Item	Standard Test Method	Test Conditions	Note	Number of Damaged
Resistance to Soldering Heat	JEITA ED-4701 300 302	Tsld=260± 5°C,10sec. 3mm from the base of the epoxy bulb	1time	0/100
Solderability	JEITA ED-4701 300 303	Tsld=235+ 5°C,5sec. (using flux)	1time over 95%	0/100
Thermal Shock	JEITA ED-4701 300 307	-40°C/15min.~100°C/15min.	100cycles	0/100
Temperature Cycle	JEITA ED-4701 100 105	-40°C/30min.~25°C/5min. ~100°C/30min.~25°C/5min.	100cycles	0/100
Moisture Resistance Cyclic	JEITA ED-4701 200 203	25°C~65°C~-10°C 90%RH 24hrs./1cycle	10cycles	0/100
Terminal Strength(bending test)	JEITA ED-4701 400 401	Load 5N(0.5kgf) 0°~90°~0°bend 2 times	No noticeable damage	0/100
Terminal Strength(pull test)	JEITA ED-4701 400 401	Load 10N(1kgf)10+1sec.	No noticeable damage	0/100
High temperature Storage	JEITA ED-4701 200 201	Ta=100°C	1000hrs.	0/100
Temperature Humidity Storage	JEITA ED-4701 100 103	Ta=60°C,RH=90%	1000hrs.	0/100
Low Temperature Storage	JEITA ED-4701 200 202	Ta=-40°C	1000hrs.	0/100
Steady state Operating Life		Ta=25°C,IF=20mA	1000hrs.	0/100
Steady State Operating Life of High Humidity Heat		60°C,RH=90%,IF=20mA	500hrs.	0/100
Steady State Operating Life of Low Temperature		Ta=-30°C,IF=20mA	1000hrs.	0/100
Resistance to UV Beam		365nm/75W/mm	192hrs.	0/100

(2)Criteria For Judging The Damage

Item	Symbol	Test Conditions	Criteria for Judgement	
			Min.	Max.
Forward Voltage	Vf	IF=20mA	-	U.S.L.*) x 1.1
Reverse Current	Ir	VR=5V	-	U.S.L.*) x 2.0
Luminous Intensity	Iv	IF=20mA	-	Inifial value x 0.7

*)U.S.L.:Upper Standard Level

**)L.S.L.:Lower Standard Level

可靠性测试:

(1) 测试项目和结果

测试项目	测试标准	测试条件	说明	允收数/样本数
回流焊	JEITA ED-4701 300 302	Tsld=260± 5°C, 10sec. 3mm from the base of the epoxy bulb	1time	0/100
焊接能力 (回流焊)	JEITA ED-4701 300 303	Tsld=235+ 5°C, 5sec. (using flux)	1time over 95%	0/100
冷热冲击	JEITA ED-4701 300 307	-40°C/15min.~100°C/15min.	100cycles	0/100
冷热循环	JEITA ED-4701 100 105	-40°C/30min.~25°C/5min. ~100°C/30min.~25°C/5min.	100cycles	0/100
高温储存	JEITA ED-4701 200 203	25°C~65°C~-10°C 90%RH 24hrs./1cycle	10cycles	0/100
抗拉强度 (弯曲实验)	JEITA ED-4701 400 401	Load 5N(0.5kgf) 0°~90°~0°bend 2 times	No noticeable damage	0/100
抗拉强度 (拉力实验)	JEITA ED-4701 400 401	Load 10N(1kgf)10±1sec.	No noticeable damage	0/100
高温贮存	JEITA ED-4701 200 201	Ta=100°C	1000hrs.	0/100
高温高湿	JEITA ED-4701 100 103	Ta=60°C,RH=90%	1000hrs.	0/100
恒温恒湿	JEITA ED-4701 200 202	Ta=-40°C	1000hrs.	0/100
常规老化实验		Ta=25°C,IF=20mA	1000hrs.	0/100
高温高湿老化实验		60°C,RH=90%,IF=20mA	500hrs.	0/100
低温才能化实验		Ta=-30°C,IF=20mA	1000hrs.	0/100
抗紫外线能力		365nm/75W/mm	192hrs.	0/100

(2) 用下列标准使用:

项目	符号	测试条件	判定标准	
			最小	最大
正向电压	Vf	IF=20mA	-	U.S.L.*) x 1.1
反向电	Ir	VR=5V	-	U.S.L.*) x 2.0
发光亮度	Iv	IF=20mA	-	Inifial value x 0.7
*)U.S.L:Upper Standard Level			**)L.S.L:Lower Standard Level	

SICHUAN JIUSHOU APPLIED ELECTRONICS CO., LTD.
SHENZHEN JIUSHOU OPTOELECTRONICS CO., LTD.

Jiuzhou Optoelectronics and the Jiuzhou logo are trademarks of Shenzhen Jiuzhou Optoelectronics, Corporation Limited in the People`s Republic of China and other countries.

Date subject to change. Copyright©2007 Shenzhen Jiuzhou Optoelectronics Corporation Limited.

All rights reserved.