

**SEVEN SEGMENT DISPLAY**

# **JZD028105R-BW**

## **DATA SHEET**

**DOCUMENT NO.: WI-RD-LDS-028105R-BW**

**RELEASE DATE: 2007-9-28**

**VERSION: A/0**

**RD No.: JZD20070928001**

# PART NO.: JZD028105R-BW

## Package Dimensions

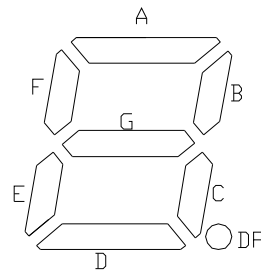
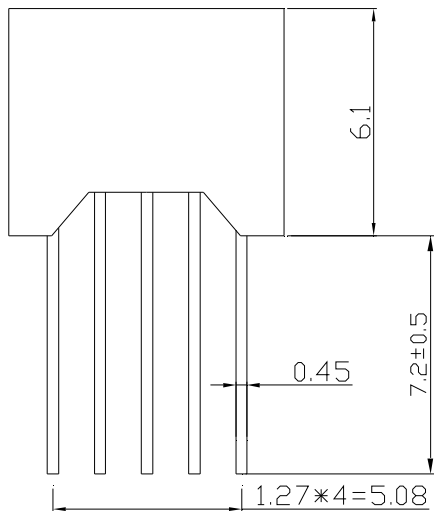
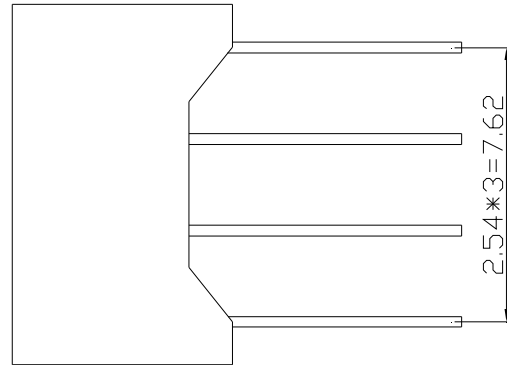
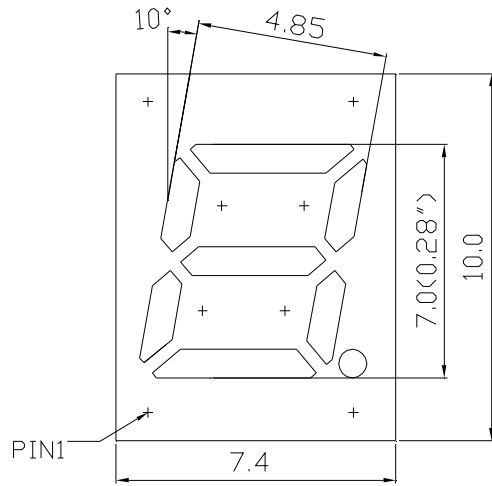

### Notes:

1. All dimension are in millimeters and(Inch)tolerance is  $\pm 0.25$ mm unless otherwise noted.
2. Specifications are subject to change without notice.

**PART NO.: JZD028105R-BW**

**Internal Circuit Diagram**

**JZD028106R-BW**

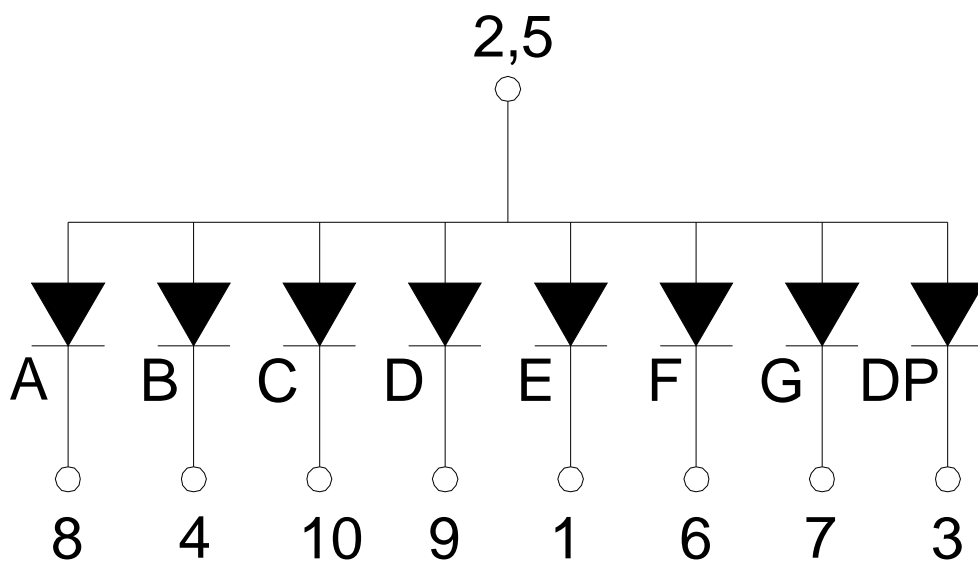

**JZD028105R-BW**

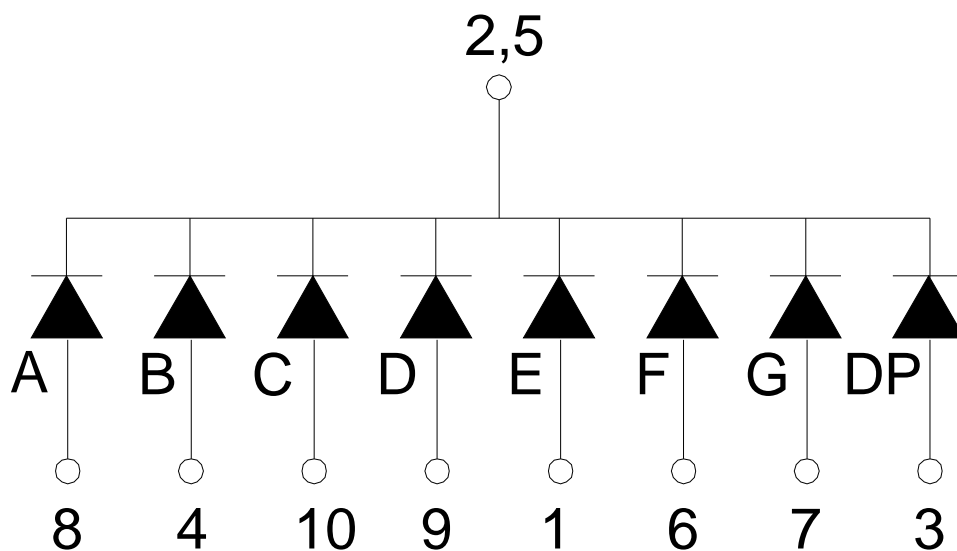

**PART NO.: JZD028105R-BW****Electrical Connection**

PIN NO.	JZD028106R-BW	PIN NO.	JZD028105R-BW
1	E segment cathode	1	E segment anode
2	Digital common anode	2	Digital common cathode
3	DP segment cathode	3	DP segment anode
4	B segment cathode	4	B segment anode
5	Digital common anode	5	Digital common cathode
6	F segment cathode	6	F segment anode
7	G segment cathode	7	G segment anode
8	A segment cathode	8	A segment anode
9	D segment cathode	9	D segment anode
10	C segment cathode	10	C segment anode
11		11	
12		12	
13		13	
14		14	
15		15	
16		16	

**Absolute Maximum Rating at=Ta=25°C**

Parameter	Symbol	Ratings	UNIT
		SGM	
Forward Current Per Chip	IF	30	mA
Peak Forward Current Per Chip*1	IFP	100	mA
Power Dissipation Per Chip	PD	100	mW
Reverse Current Per Any Chip	Ir	50	uA
Electrostatic Discharge*2	ESD	1000	V
Operating Temperature	Topr	-25~+85	°C
Storage Temperature	Tstg	-25~+85	°C

Solder Temperature 1/16 Inch Below Seating Plane For 3 Seconds At 260°C

\*1:Duty 1/10,0.1ms Pulse With

\*2:Static Electricity or power surge will damage the LED. Use of a conductive wrist band or anti-electrosatic glove is recommended when handing these LED. All devices, equipment and machinery must be properly grounded.

## PART NO.: JZD028105R-BW

### Part selection And Application Information(Ratings at 25°C)

PART NO.	COLOR ( EPOX Y/SURF ACE )	CHIP		Common cathode or anode	WD (nm )	Electrical				IV- M
		Material	Emitted			Vf(v)		Iv(mcd)		
						Typ.	Max.	Min.	Typ.	
JZD028105R-BW	WHITE DIFFUS E/BLAC K	GaP	RED	Common cathode	644	1.9	2.4	9	10	1: 1.1

Note:1.The forward voltage data did not including  $\pm 0.01V$  testing tolerance.

2.The luminous intensity data did not including  $\pm 15\%$  testing tolerance.

### Test Condition For Each Parameter

Parameter	Symbol	Unit	Test Condition
Forward Voltage Per Chip	Vf	volt	If=20mA
Luminous Intensity Per Chip	Iv	mcd	If=20mA
Peak Wavelength	WP	nm	If=20mA
Dominant Wavelength	WD	nm	If=20mA
Spectral Line Half-Width	$\Delta W$	nm	If=20mA
Reverse Current Any Chip	Ir	$\mu A$	If=20mA
Luminous Intensity Matching Ratio	IV-M		

# Typical Optical-Electronic Characteristic Curves

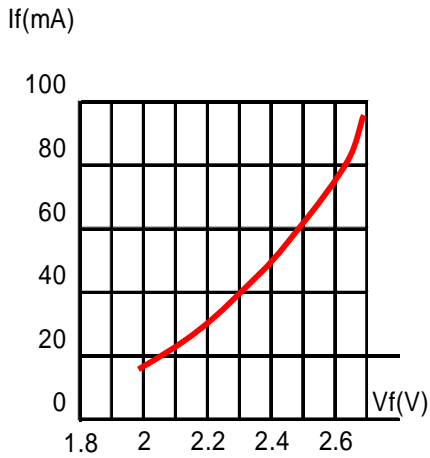
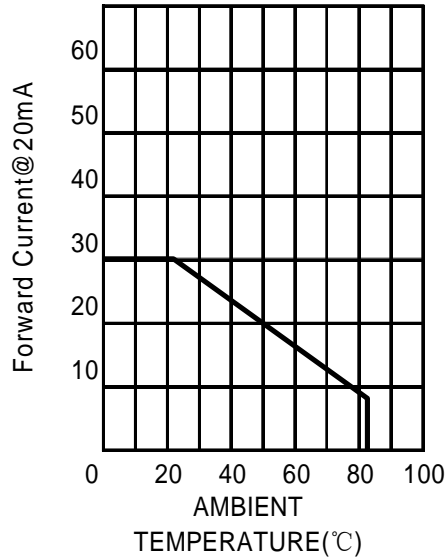

Fig.1 FORWARD CURRENT VS. FORWARD



AMBIENT TEMPERATURE(°C)

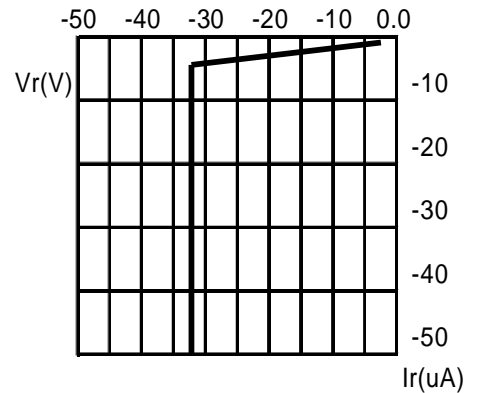

Fig.2 REVERSE CURRENT VS. REVERSE VOLTAGE.

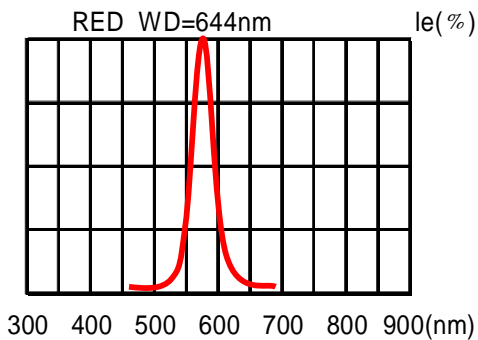
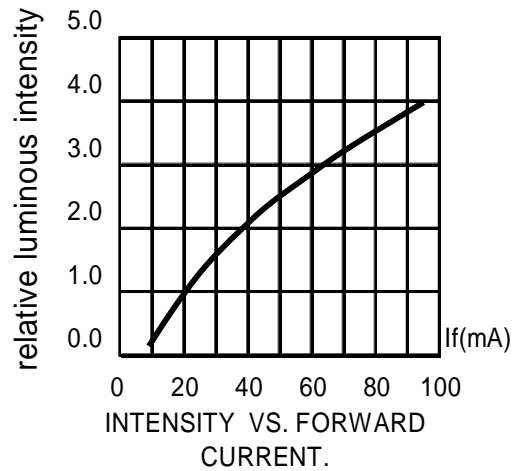

Fig.4 RELATIVE LUMINOUS INTENSITY VS. WAVELENGTH.



INTENSITY VS. FORWARD CURRENT.

## Soldering Condition (Pb-Free)

### 1. Iron:

Soldering Iron: 30W Max

Temperature 350°C Max

Soldering Time: 3 Seconds Max (One time only)

Distance: Solder Temperature 1/16Inch Below Seating Plane

For 3 Seconds At 260°C

### 2. Wave Soldering Profile

Dip Soldering

Preheat: 120°C Max

Preheat time: 60 seconds Max

Ramp-up

2°C/sec(max)

Ramp-Down: -5°C/sec(max)

Solder Bath: 260°C Max

Dipping Time: 3 seconds Max

Distance: Solder Temperature 1/16Inch Below Seating Plane for 3 Seconds At 260°C

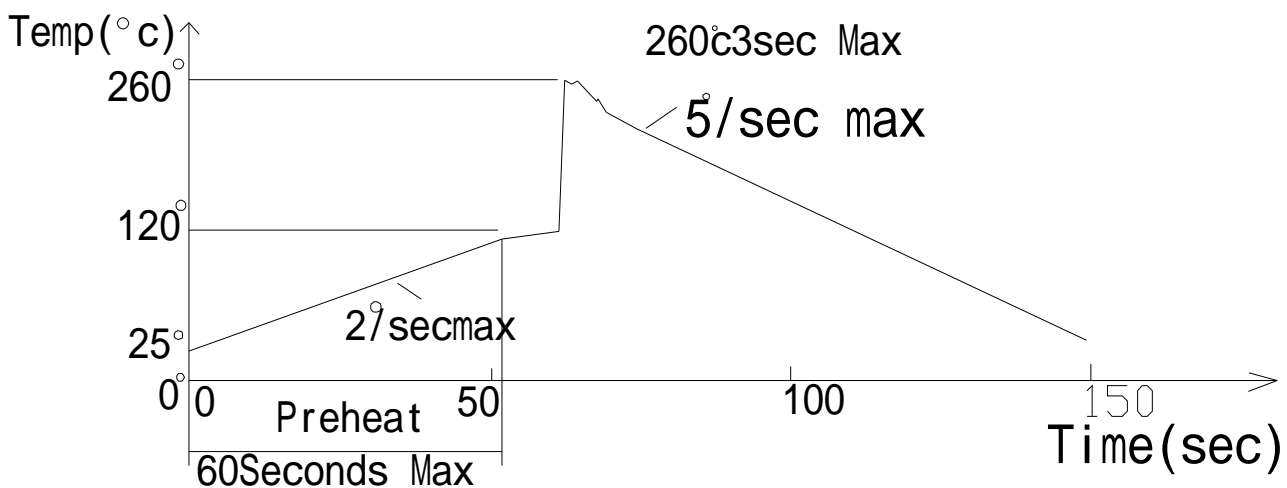

Note: 1. Wave solder should not be made more than one time.

2. You can just only select one of the soldering conditions as above.

## Reliability Test:

Test Item	Standard Test Method	Test Condition	Description
Operating Life Test	JIS C7021:B-1 MIL-STD-750:1026 MIL-STD-883:1005	1. Under Room Temperature 2. If=10 mA 3. t=1000hrs(-24hrs,+72hrs)	This test is conducted for the purpose of deteming the resistance of a part in electrical and themal stressed.
High Temperature Storage Test	JIS C 7021:B-10 MIL-STD-883:1008	1. Ta=105°C±5°C 2. t=1000hrs(-24hrs,+72hrs)	The purpose of this is the resistance of the device which is laid under condition of high temperature for hours.
Low Temperature Storage Test	JIS C 7021:B-12	1. Ta=-40°C±5°C 2. t=1000hrs(-24hrs,+72hrs)	The purpose of this is the resistance of the device which is laid under condition of low temperature for hours.
High Temperature High Humidity Test	JIS C 7021:B-11 MIL-STD-202:103B	1. Ta=65°C±5°C 2. RH=90%~95% 3. Tt=240hrs±2hrs	The purpose of this id the resistance of the device which is laid under condition of low temperature for hours.
Thermal Shock Test	MIL-STD-202:107D MIL-STD-750:1051 MIL-STD-883:1011	1. Ta=105 °C ±5 °C & -40 °C ±5 °C (10min)(10min)	The purpose of this is the resistance of the device to sudden extreme changes in high and low temperature.
Solder Resistance Test	JIS C 7021:A-1 MIL-STD-202:210A MIL-STD-750:2031	1.T.Sol=260°C±5°C 2.Dwell time=10±1sec.	This test intended to determine the thermal characteristic resistance of the device to sudden exposures at ex treme changes in temperature when soldering the lead wire.
Solderability Test	JIS C 7021:A-2 MIL-STD-202:208D MIL-STD-750:2026 MIL-STD-883:2003	1.T.Sol=230°C±5°C 2.Dwell time=5±1sec.	This test intended to see soldering well performed or not.

**SICHUAN JIUZHOU APPLIED ELECTRONICS CO., LTD.**

**SHENZHEN JIUZHOU OPTOELECTRONICS CO., LTD.**

Add: Building 7,(Lantian Technology Park) Shaer Industry Ditang Road,  
Shajing Street, Baoan District Shenzhen City, China

Tel: +86 755 33806780 33806781 33806782

Fax: +86 755 33806789

ZIP Code:518104

[www.jz-led.com](http://www.jz-led.com)

For product information and a complete list of distributors, please visit our website.

For technical assistance call:

Domestic Tel: +86 755 33806780 33806781 33806782 ext: 8787

Overseas Tel: +86 755 83456976

Jiuzhou Optoelectronics and the Jiuzhou logo are trademarks of Shenzhen Jiuzhou Optoelectronics,Corporation Limited in the Pepole`s Republic of China and other countries.

Date subject to change. Copyright©2007 Shenzhen Jiuzhou Optoelectronics Corporation Limited.

All right reserved.