

LTS028R-ASBW-E2

Features:

- 0.28"height, Four Digital
- Emitting Color: Red 624nm
- White diffused segment, Gray surface
- Low current operation
- Common Anode
- ROHS compliant

Dice Material: GaP



Package Dimension

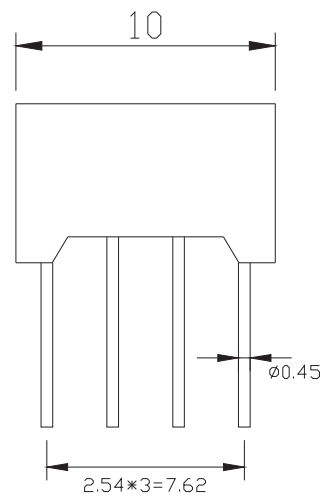
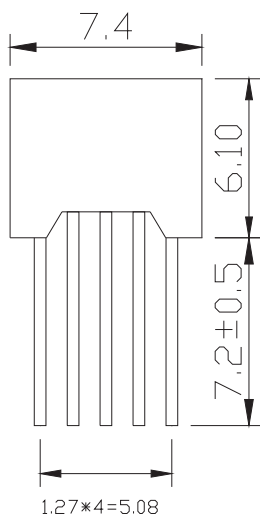
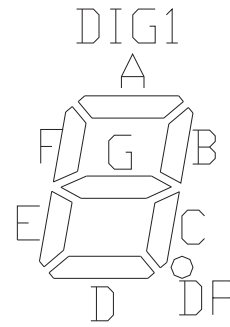
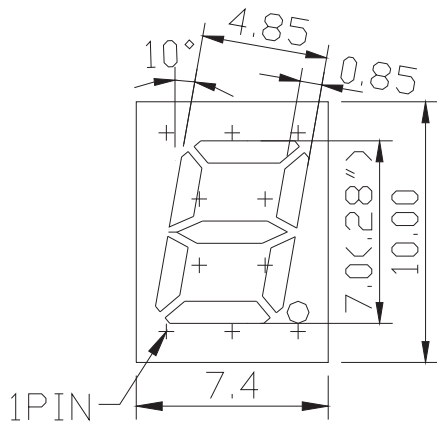

Internal Circuit Diagram

COMMON ANODE

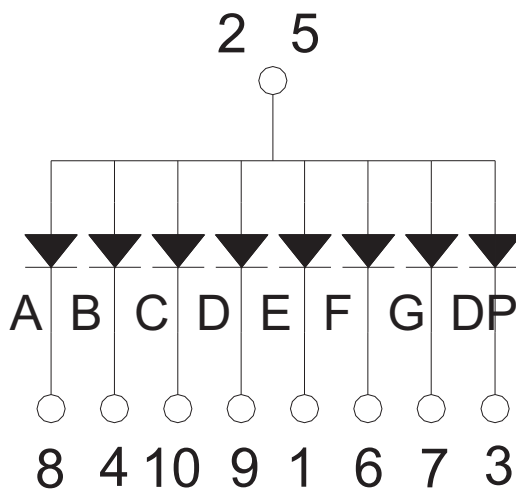

COMMON ANODE	
PIN NO.	FUNCTION
1	E segment cathode
2	Digital common anode
3	Digital common anode
4	C segment cathode
5	DP segment cathode
6	B segment cathode
7	A segment cathode
8	Digital common anode
9	F segment cathode
10	G segment cathode

Absolute Maximum Ratings @Ta=25°C

Parameter	Dark Red	Unit
Power Dissipation Per Segment	75	mW
Peak Forward Current Per Segment	120	mA
Continuous Forward Current Per Segment Derating Linear From 25°C Per Segment	25	mA
	0.20	mA/°C
Reverse Voltage Per Segment	5	V
Operating Temperature Range	-25°C +85°C	
Storage Temperature Range	-25°C +85°C	

Electrical/Optical Characteristics @Ta=25°C

Parameters	Symbol	Min	Typ	Max	Unit	Test Condition
Average Luminous Intensity	I _v	80	90	--	mcd	If=20mA
Emissions Wavelength	λ _D	620	624	--	nm	If=20mA
Forward Voltage, Per Dot	V _f	1.8	2.0	2.4	V	If=20mA
Reverse Current, Per Dot	I _R	/	/	50	uA	Vr=5V
Luminous Intensity Matching Ratio	I _{v-m}		/	1:1.2	/	If=10mA

Important Notes:

1. V_f maximum tolerance include is ±0.1V.
2. I_v maximum tolerance include is ±15%.
3. λ_D maximum tolerance include is ±1nm.

Typical Optical-Electronic Characteristic Curves

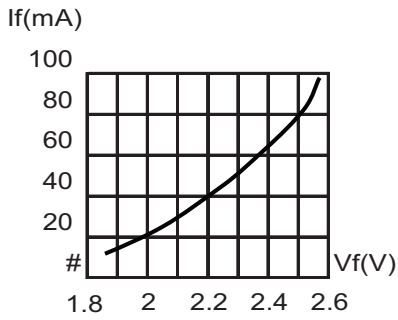
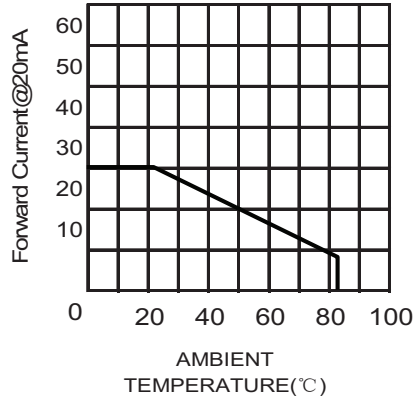

Fig.1 FORWARD CURRENT VS. FORWARD VOLTAGE.



AMBIENT TEMPERATURE(°C)

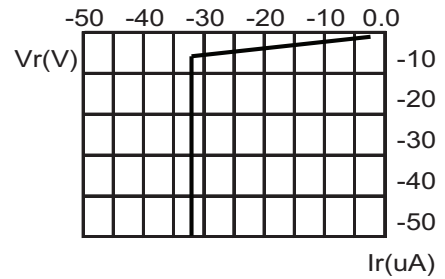

Fig.2 REVERSE CURRENT VS. REVERSE VOLTAGE.

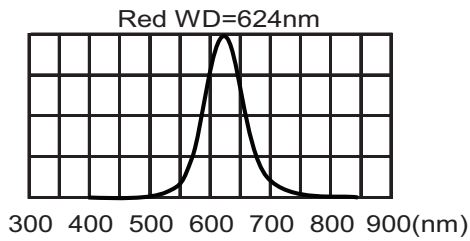

Fig.4 RELATIVE LUMINOUS INTENSITY VS. WAVELENGTH.

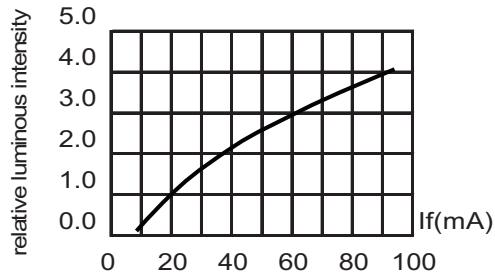

Fig.3 RELATIVE LUMINOUS INTENSITY VS. FORWARD CURRENT.

Items	Signatures	Date
Prepared by	Zeng Yo Xian	04-25-2009
Checked by	Guo Lo	04-25-2009
Approved by	Qang Shi	04-25-2009
FCN#	/	

Revision History		
Rev. No.	Date	Change Description
/	/	/