



# SPECIFICATIONS FOR LCD MODULE

**MODEL NO.**  
**TP320240AAC0**  
**VER.01**

FOR MESSRS:

---

ON DATE OF:

---

APPROVED BY:

---

**BOLYMIN, INC.**  
13F-1, 20, TA-LONG RD., TAICHUNG CITY 403, TAIWAN, R.O.C.  
WEB SITE:<http://www.bolymin.com.tw> TEL:+886-4-23293029 FAX:+886-4-23293055



# TABLE OF CONTENTS

1. FEATURES.....	Page4
2. GENERAL SPECIFICATION.....	Page4
3. ENVIRONMENTAL CHARACTERISTICS.....	Page5
4. OPTICAL CHARACTERISTICS.....	Page5
5. ELECTRICAL CHARACTERISITCS.....	Page5
6. MECHANICAL CHARACTERISTICS.....	Page6
7. RELIABILITY.....	Page6
8. DURABILITY.....	Page6
9. INSPECTION METHODS.....	Page7
10. APPEARANCE INSPECTION.....	Page8
11. ATTENSION FOR MOUNTING CONDITION.....	Page9
12. GUARANTY.....	Page9
13. CAUTIONS.....	Page10
14. APPENDICES.....	Page10
15. APPENDIX I : APPEARANCE SPECIFICATION .....	Page11
16. APPENDIX II : DURABILITY TEST METHOD.....	Page12
17. APPENDIX III : CAUTIONS FOR PRODUCT HANDING..... ;	Page13

## 1. FEATURES

Type	Four-Wire Analog Resistive Touch Panel		
Structure	Material	Thickness	Type
	ITO/PET	188um	Non-Glare
	ITO/GLASS	1.1mm	Normal type
Input Mode	Stylus or Finger		
Connector	FPC		

## 2. GENERAL SPECIFICATION

Item	Specification (unit in mm except as noted)
(1) Frame Size	137.50 ± 0.30 × 107.50 ± 0.30
(2) View Area	122.60 ± 0.20 × 93.80 ± 0.20
(3) Active Area	116.20 ± 0.20 × 87.30 ± 0.20
(4) Total Thickness	1.35 ± 0.15
(5) Tail Length	79.10 ± 1.00

### 【Engineering Drawing】

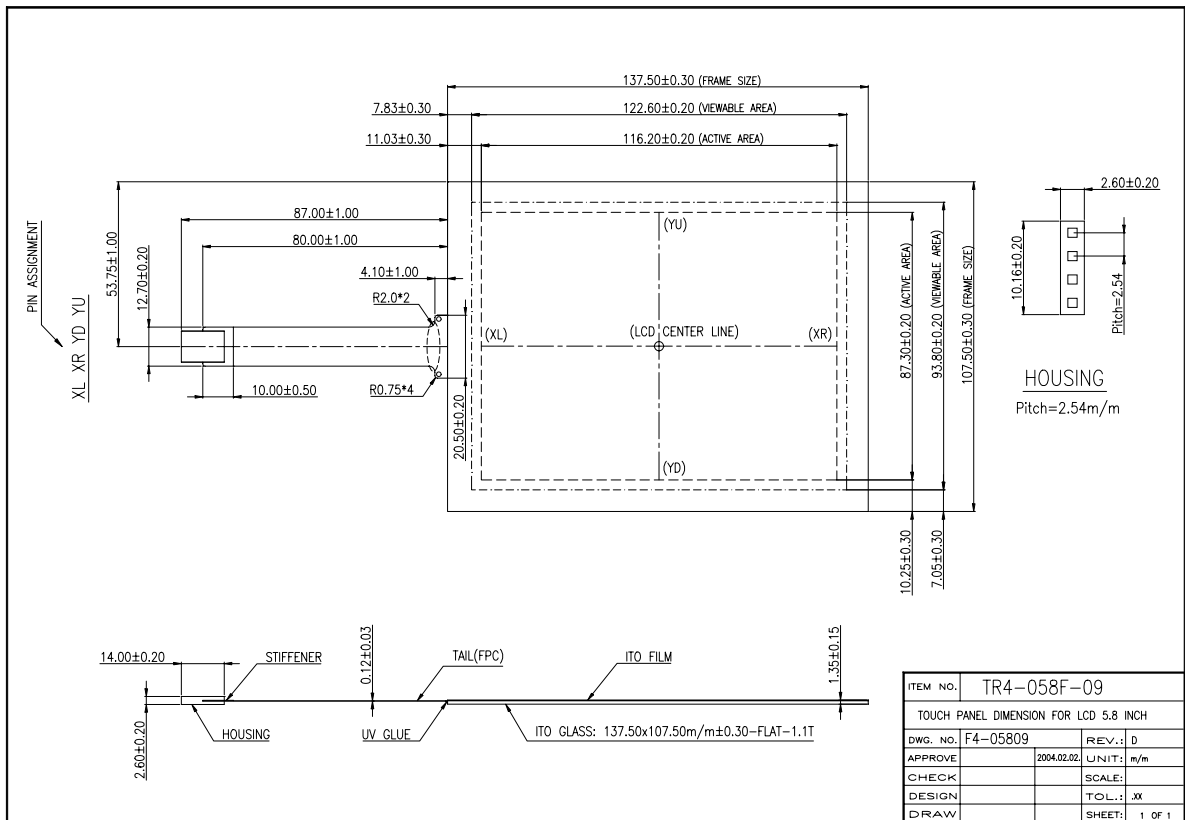

**3. ENVIRONMENTAL CHARACTERISTICS**

Status	Temperature	Humidity (No Condensation)
(1) Operation	0°C ~ +50°C	20% - 85%RH
(2) Storage	-20°C ~ +70°C	10% - 90%RH

*Note: The environment is of normal atmosphere pressure.*

**4. OPTICAL CHARACTERISTICS**

Item	Specification
(1) Transparency	$\geq 78\%$ @wave length 550nm
(2) Newton Ring	As per actual samples provided

*Note1: Transparency and Haze is measured by using BYK-Gardner instrument.*

*Note2: Test method-satisfy(2) of Item 10.*

**5. ELECTRICAL CHARACTERISTICS**

Item	Specification
(1) Terminal Resistance	Up : 200~700Ω,Down : 500~1000Ω
(2) Linearity	X axis $\leq 1.5\%$ ,Y axis $\leq 1.5\%$ (Test method reference Item 9)
(3) Chattering	$\leq 30\text{ms}$
(4) Insulation	$\geq 20\text{M}\Omega/25\text{V(DC)}$
(5) Endurance	No arcing damage at DC 25V/60sec.
(6) Operative Resistance	$\leq 2\text{K}\Omega$

**6. MECHANICAL CHARACTERISTICS**

	Item	Condition	Specification
(1)	Operation Force	Stylus = R0.8	≤ 50g
(2)	Impact	13.0 φ DIA. Steel Ball/9g Height = 30cm	1 time, no damage (Impact at center area)
(3)	Static Load	5kg at φ 10 mm area for 30 Sec	Satisfy (1),(2),(4) Of Item 5 and (1) of Item 6
(4)	Hardness	3H pencil, pressure 1n/45 ° (JIS K5400)	≥ 3H
(5)	Peeling	800g/cm by 90 degree	Satisfy (1) Of Item 5
(6)	Bending	10 times by radius R:1mm 500g left & right 135 degree	Satisfy (1) Of Item 5

**7. RELIABILITY**

	Item	Condition	Specification
(1)	Constant Temperature / Humidity	60°C/90%RH ,120 hrs and normalized for 4 hrs	Satisfy (1),(2), of Item 4; (1),(2),(4) Of Item 5; (1) of Item 6
(2)	Heat Cycle	70°C/120 hrs and normalized for 4 hrs	Same as above
(3)	Cold Cycle	-20°C/120 hrs and normalized for 4 hrs	Same as above
(4)	Thermal Cycle	-20°C~+70°C(0.5hr each), 10 Cycles (within 24 hr) and normalized for 4 hrs	Same as above

**8. DURABILITY**

	Item	Condition	Specification
(1)	Write Test	100,000 times, Force 250g , R0.8	Satisfy(1),(2),(4) of Item 5; (1) of Item 6
(2)	Knock Test	1,000,000 times , Force 250g , 3HZ, R8/HS60	Same as above

**9.INSPECTION  
METHODS**

(1) Linearity Condition

Voltage (DC 5V) is applied to X1 or Y2 and ground (0V) is applied to X2 or Y1.

Using stylus to draw straight lines (LX and LY) at 5 mm intervals within active area and detect the voltage at Y2 or X1.  
To Measure the voltage differences between X1 and X2 or Y1 and Y2.

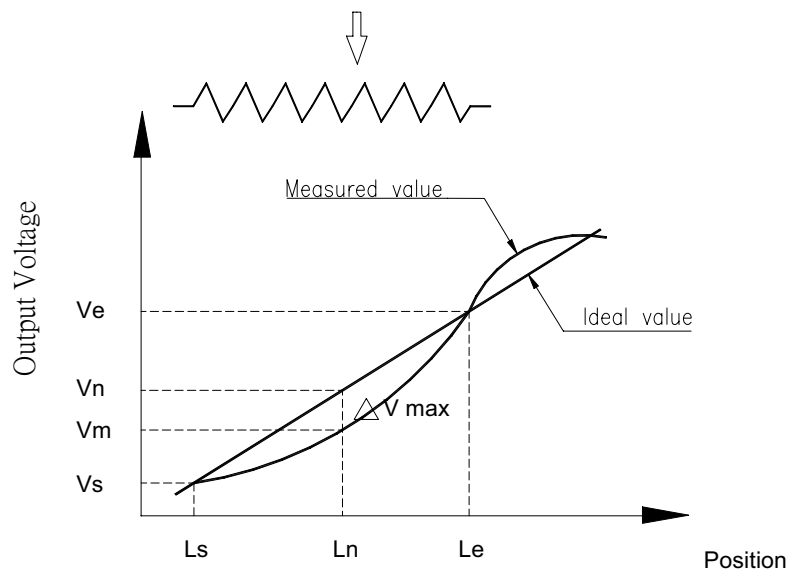
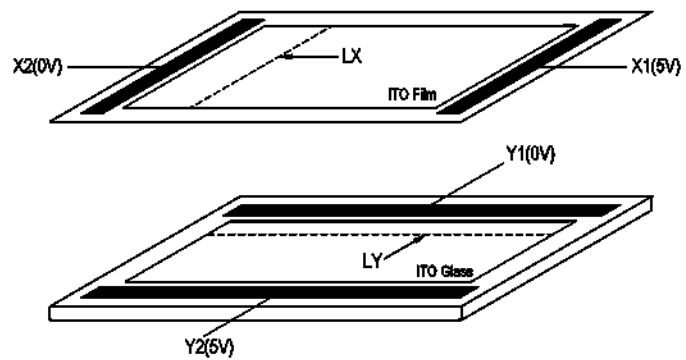

$$\text{Linearity} = \frac{\Delta V \text{ max}}{(Ve-Vs)} \times 100\%$$

**10.APPEARANCE INSPECTION**

- (1) The flaws and impurities are allowed outside viewing area except for those affecting electrical functions.
- (2) The inspection shall be performed by using one 17w fluorescent lamp as back or side light. The panel shall be placed at 30cm away from eyes (as illustrated in the followings).

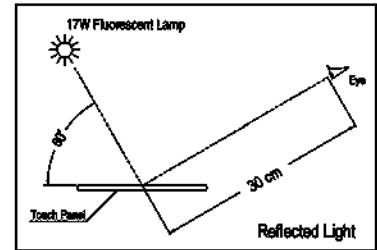
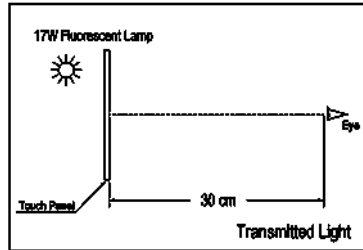

(3) Glass flaw

Corner flaw		$X \leq 3.0\text{mm}$ $Y \leq 3.0\text{mm}$ $Z \leq T$
Edge flaw		$X \leq 3.0\text{mm}$ $Y \leq 3.0\text{mm}$ $Z \leq T$
Progressive flaw		None allowed

T=Glass thickness

Please refer to Appendix I : Appearance Specification.

## 11.ATTENTION FOR MOUNTING CONDITION

(1) The Support which fixes the touch panel must be designed outside of Viewable Area.

To avoid accidental pressing on touch panel, Enclosure must be designed with enough clearance to panel surface.

(2) Bezel opening must be between Viewable Area and Active Area..  
Bezel opening must not touch Viewable Area.

(3) We recommend elastic material made Support.

(4) Do not use adhesive to bond Top Surface (ITO Film) of touch panel with Enclosure.

(5) Edges of touch panel is conductive.

Do not touch it with metal after mounting.

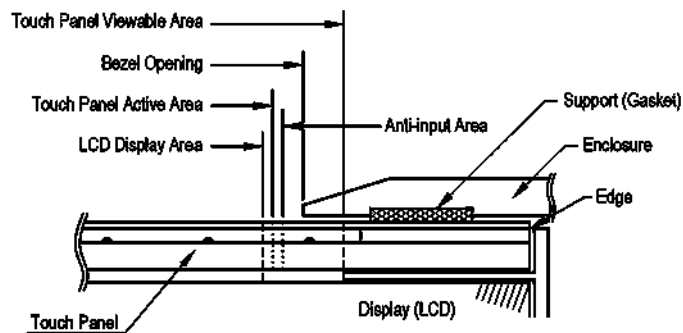

## 12.GUARANTY

With the exceptions listed below, all Liyitec's products are guaranteed free of manufacturing defects for a period of up to one year. All defected products will be repaired or exchanged free of charge if determined to be the responsibility of Liyitec. Liyitec reserves the sole discretion in determining the causes and the responsibilities of any defects or damages.

List of Exceptions:

1. Damages caused by improper handling of clients, including and not limited to, during shipping or manufacturing processes.
2. Damages caused by disasters, either by natural causes or human factors, after the delivery of products.
3. Any repairs, modifications or disassembling of Liyitec's products without prior notification to and the consent of Liyitec.

### 13.CAUTIONS

Storage	(1) Store packaged products at the temperature and humidity mentioned in the specification with care. Do not expose products to direct sunlight or stress such as that caused by piling.
Unpacking	(1) Check for the correct vertical direction of the package before unpacking.
Handling	(1) Clean finger sacks or gloves and mask are required during handling to prevent finger-prints or stain on the products and damages to the products caused by sharp edges. (2) Do not handle the viewing area of the panel. (3) Do not handle the panel at the tail (connector) to prevent detachment of the tail to the panel.
Cleaning	(1) Clean and soft clothes with neutral detergent or with ethanol may be used for cleaning. (2) Do not use any chemical solvent, acidic or alkali solution. (3) Do not allow liquid from soaking into the joint of film and glass which may result in peeling or malfunctioning.
Installing and Assembling	(1) Excessive force or strain to the panel or the tail is prohibited. (2) Provide a clearance of at least 0.3mm between panel and display module. (3) The panel is designed with air groove. Insulation and cushioning pads should be designed around the edges of the panel to prevent liquid penetration or dust gathering.
Operating	(1) Operate with a stylus (tip R0.8 or over), or with a finger without applying excessive load. Sharp edged or hard articles are prohibited. (2) The gathering of dew in the panel may occur with abrupt temperature or humidity changes. A stable environment condition is recommended.
Others	(1) Keep the surface clean. No adhesives should be applied. (2) Avoid high voltage and static charge. (3) Liyitec reserves the right to substitute materials with the same grade and specification.

絕對禁止沿著機殼四周邊緣做劃線動作，如此會令 PET/FILM 因承受極大的壓力而破壞，更會因此而使得 Touch Panel 喪失功能。如圖。

It is absolutely forbidden to draw lines along with the edge of the housing because the extreme force will damage the PET/FILM and cause the failure of the touch panel.

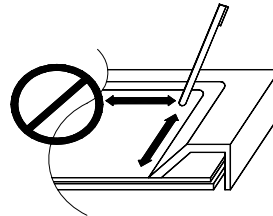

### 14.APPENDICES

Appendix I	Appearance Specification	1 page
Appendix II	Durability Test Method	1 page
Appendix III	Cautions for Product Handling	1 page

# Appearance Specification

**【Appendix-1】**

Unit : mm Page:1/1

<b>Particle</b>	( 1 ) Diameter $\leq 0.2$ , Total $\leq 3$ particles → OK ( 2 ) $0.2 < \text{Diameter} \leq 0.25$ , Total $\leq 3$ particles → OK ( 3 ) Diameter $> 0.25$ → NG
<b>Blur Stain</b>	( 1 ) Diameter $\leq 0.2$ , Total $\leq 3$ particles → OK ( 2 ) $0.2 < \text{Diameter} \leq 0.25$ , Total $\leq 3$ particles → OK ( 3 ) Diameter $> 0.25$ → NG
<b>Linear Object</b>	( 1 ) Width $\leq 0.05$ and Length $\leq 12$ → OK ( 2 ) Total $\leq 3$ objects → OK ( 3 ) Total $> 3$ objects → NG ( 4 ) Curled objects are regarded as particles
<b>Blister</b>	( 1 ) Not allowed
<b>Fish Eye (Spread White Spots)</b>	( 1 ) Diameter $\leq 0.3$ and total $\leq 3$ Spots → OK ( 2 ) Diameter $> 0.3$ → NG
<b>Newton Ring</b>	( 1 ) As per actual samples provided
<b>Color Tone</b>	( 1 ) As per actual samples provided
<b>Scratch</b>	( 1 ) Width $\leq 0.025$ and Length $\leq 12$ , Total $\leq 3$ scratches → OK ( 2 ) Width $\leq 0.05$ and Length $\leq 12$ , Total $\leq 1$ scratches → OK ( 3 ) Width $> 0.05$ or Length $> 12$ → NG
<b>Interference Pattern</b>	( 1 ) Inspection according to the standard testing methods
<b>Damages to Glass</b> A. Corner B. Edge	( 1 ) Length $\leq 2$ , Width $\leq 2$ , Depth $\leq 1/3T$ , Total 2 damages → OK ( 2 ) Damages with possible worsening disallowed

## 【Appendix- II】

### 1. Write Test :

- Test Position : Center in Active Area 20mm×20mm (Fig 1)
- Test Speed : 100mm/sec
- Load Force : 250g
- Test pen : R0.8 polyacetal Stylus , (Fig 2)
- Test method : Write 100,000 characters in active area °

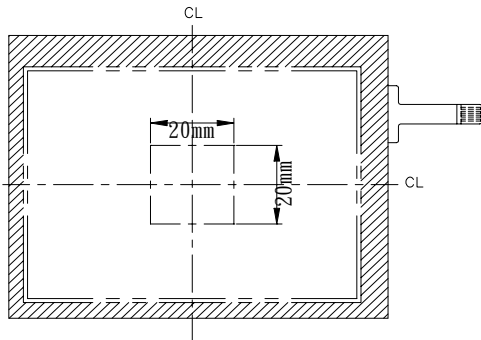

【Fig 1】

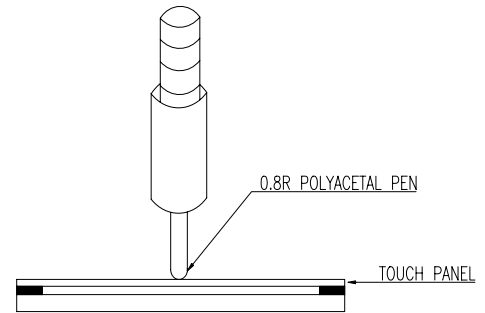

【Fig 2】

### 2. Knock Test :

- Test Position : Center in Active Area (Fig 3)
- Test Speed : 3 Hz
- Load Force : 250g
- Test pen : R8.0 Silicon Rubber Hs60°(Fig 4)
- Test method : 1,000,000 times in same position

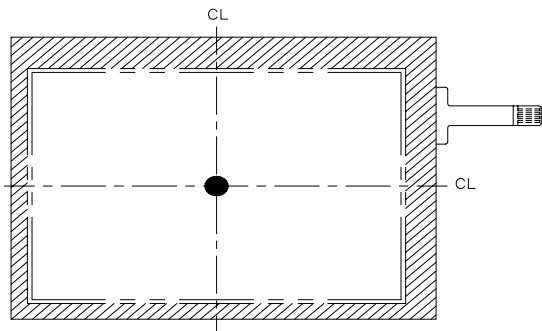

【Fig 3】

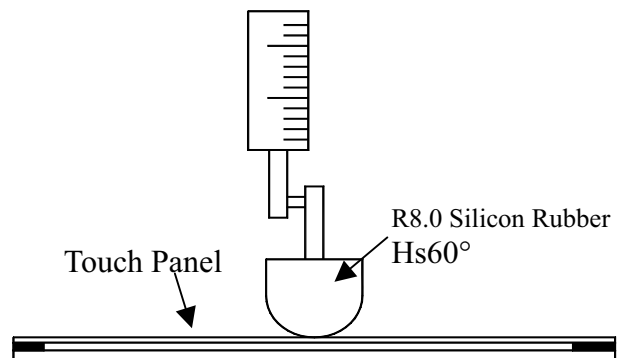

【Fig 4】