

# L. S. TECH Co., Ltd.

Professional Varistors Maker

MOV

VARISTORS

Zinc Oxide Varistors

ZOV

METAL OXIDE VARISTORS

**CONTENT**

» General Introduction .....	2
» Part Numbering System .....	3
» Marking .....	4
» Certifications List of Standard Series .....	5
» Taping Specification for 05D & 07D .....	6
» Taping Specification for 10D, 14D & 20D .....	7
» Packaging .....	8
» 05D Specification .....	9
» 07D Specification .....	10
» 10D Specification .....	11
» 14D Specification .....	12
» 20D Specification .....	13
» 25D Specification .....	14
» 32D Specification / Dimension .....	15
» 40D Specification / Dimension .....	16
» 53D Specification / Dimension .....	17
» 34S Specification / Dimension .....	18
» 34S Dual-discs Specification / Dimension .....	19
» 34B Specification / Dimension .....	20
» 60B Specification / Dimension .....	21
» Terminology and General Characteristics Definition / Electrical .....	22
» Terminology and General Characteristics Definition / Mechanical .....	24
» Terminology and General Characteristics Definition / Environmental .....	25
» How to Select A Varistor .....	26

► **Introduction**

Zinc Oxide Varistors(ZOV, aka MOV) are nonlinear two-electrode semiconductor voltage-dependant resistors, which are designed for transient voltage suppression and surge energy absorption. Transient over-voltages are major causes for malfunction or total failure of electronic circuitry and equipment. Therefore, varistors can be widely applied in different areas. Our products perform very reliably and experience low failure rates. Most of them are UL, CSA and VDE approved. Now RoHS complaint varistors are also available.



File no. E207368



File no. LR115266



File no. 4005858







Features
<ul style="list-style-type: none"> <li>■ Wide Operating voltage range, Vdc form 14V to 1465V</li> <li>■ Large absorbing transient energy capability</li> <li>■ Very short response time</li> <li>■ Low clamping ratio and no follow-on current</li> <li>■ High resistance insulation material prevents the electric arching to the adjacent devices.</li> </ul>
Applications
<ul style="list-style-type: none"> <li>■ Transistor, diode, IC, thyristor or triac semiconductor protection</li> <li>■ Surge protection in consumer electronics</li> <li>■ Surge protection in industrial electronics</li> <li>■ Surge protection in communication, measuring and controller electronics</li> <li>■ Surge protection in electronic home appliances and gas/petroleum appliances.</li> <li>■ Electrostatic discharge and noise spike suppression</li> <li>■ Relay and electromagnetic valve surge absorption</li> </ul>

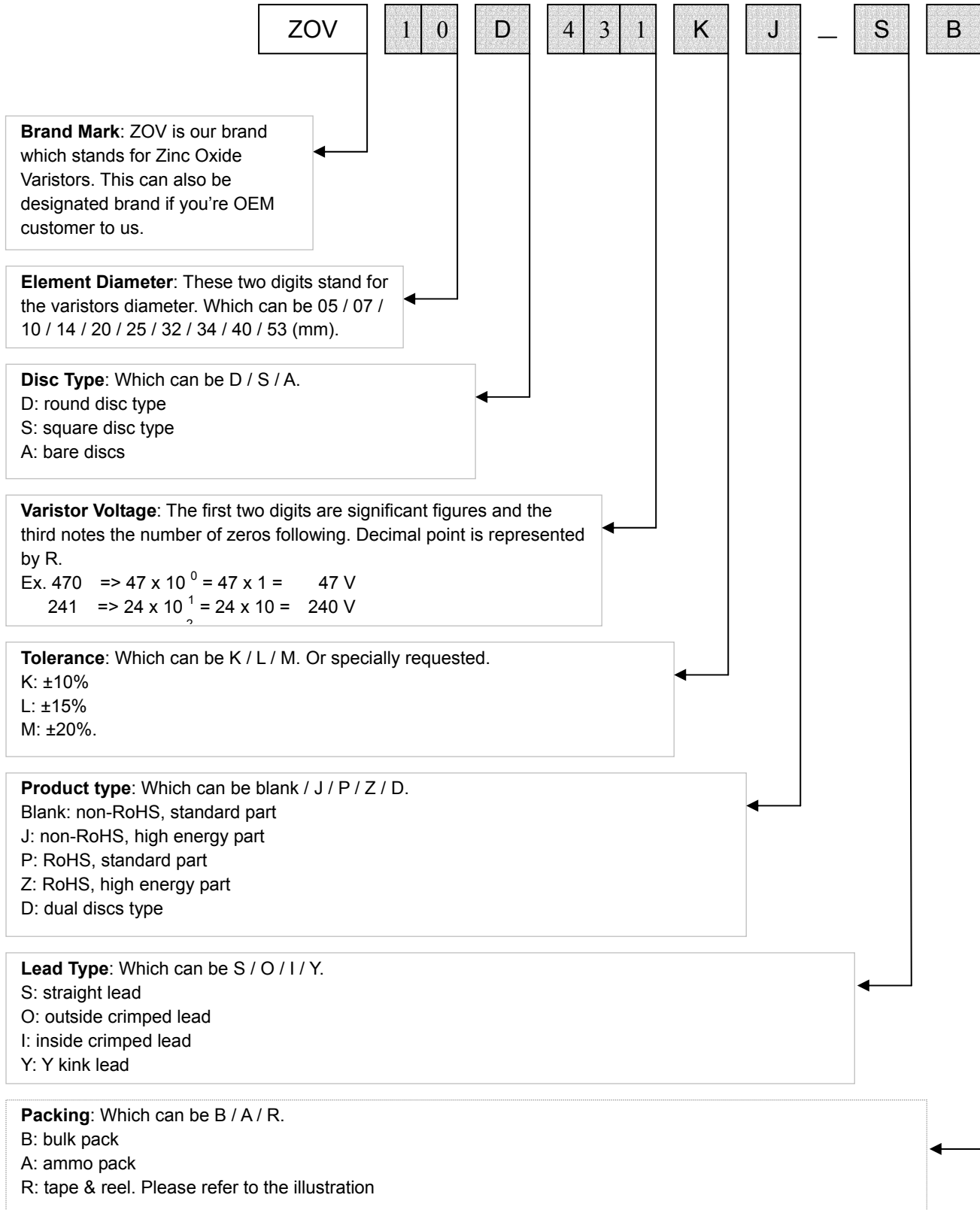



## ► Part Numbering System

Please refer to the following part numbering system when you place order.



► **Marking**

GREEN epoxy coating for RoHS compliant		
Standard Part		High Energy
		
Row	Marking	Description
1 <sup>st</sup>	ZOV	Brand of varistors
2 <sup>nd</sup>	10D431K	10mm, varistor voltage 430V with +/-10% tolerance
3 <sup>rd</sup>	 F01P(Z)	UL marking, CSA marking if any F01: date code, F stands for year 2006 and 01 are calendar week of the year P / Z: standard or high energy part
4 <sup>th</sup>		VDE marking if any

BLUE epoxy coating for non-RoHS compliant		
Standard Part		High Energy
		
Row	Marking	Description
1 <sup>st</sup>	ZOV	Brand of varistors
2 <sup>nd</sup>	10D431K	10mm, varistor voltage 430V with +/-10% tolerance
3 <sup>rd</sup>	 F01(blank)Z	UL marking, CSA marking F01: date code, F stands for year 2006 and 01 are calendar week of the year blank / J: standard or high energy part
4 <sup>th</sup>		VDE marking

## ► Certifications List of Standard Series

Disc Part no.	05D			07D			10D			14D			20D		
	UL	CSA	VDE	UL	CSA	VDE	UL	CSA	VDE	UL	CSA	VDE	UL	CSA	VDE
180K	☆	☆	☆	☆	☆	☆	☆	☆	☆	☆	☆	☆	☆	☆	☆
220K	☆	☆	☆	☆	☆	☆	☆	☆	☆	☆	☆	☆	☆	☆	☆
270K	☆	☆	☆	☆	☆	☆	☆	☆	☆	☆	☆	☆	☆	☆	☆
330K	☆	☆	☆	☆	☆	☆	☆	☆	☆	☆	☆	☆	☆	☆	☆
470K	☆	☆	☆	☆	☆	☆	☆	☆	☆	☆	☆	☆	☆	☆	☆
560K	☆	☆	☆	☆	☆	☆	☆	☆	☆	☆	☆	☆	☆	☆	☆
680K	☆	☆	☆	☆	☆	☆	☆	☆	☆	☆	☆	☆	☆	☆	☆
820K	☆	☆	☆	☆	☆	☆	☆	☆	☆	☆	☆	☆	☆	☆	☆
101K	☆	☆	☆	☆	☆	☆	☆	☆	☆	☆	☆	☆	☆	☆	☆
121K	☆	☆	☆	☆	☆	☆	☆	☆	☆	☆	☆	☆	☆	☆	☆
151K	☆	☆	☆	☆	☆	☆	☆	☆	☆	☆	☆	☆	☆	☆	☆
181K	☆	☆	☆	☆	☆	☆	☆	☆	☆	☆	☆	☆	☆	☆	☆
201K	☆	☆	☆	☆	☆	☆	☆	☆	☆	☆	☆	☆	☆	☆	☆
221K	☆	☆	☆	☆	☆	☆	☆	☆	☆	☆	☆	☆	☆	☆	☆
241K	☆	☆	☆	☆	☆	☆	☆	☆	☆	☆	☆	☆	☆	☆	☆
271K	☆	☆	☆	☆	☆	☆	☆	☆	☆	☆	☆	☆	☆	☆	☆
301K	☆	☆	☆	☆	☆	☆	☆	☆	☆	☆	☆	☆	☆	☆	☆
331K	☆	☆	☆	☆	☆	☆	☆	☆	☆	☆	☆	☆	☆	☆	☆
361K	☆	☆	☆	☆	☆	☆	☆	☆	☆	☆	☆	☆	☆	☆	☆
391K	☆	☆	☆	☆	☆	☆	☆	☆	☆	☆	☆	☆	☆	☆	☆
431K	☆	☆	☆	☆	☆	☆	☆	☆	☆	☆	☆	☆	☆	☆	☆
471K	☆	☆	☆	☆	☆	☆	☆	☆	☆	☆	☆	☆	☆	☆	☆
511K	☆	☆	☆	☆	☆	☆	☆	☆	☆	☆	☆	☆	☆	☆	☆
561K	☆	☆	☆	☆	☆	☆	☆	☆	☆	☆	☆	☆	☆	☆	☆
621K				☆	☆	☆	☆	☆	☆	☆	☆	☆	☆	☆	☆
681K				☆	☆	☆	☆	☆	☆	☆	☆	☆	☆	☆	☆
751K							☆	☆	☆	☆	☆	☆	☆	☆	☆
781K							☆	☆	☆	☆	☆	☆	☆	☆	☆
821K							☆	☆	☆	☆	☆	☆	☆	☆	☆
911K							☆	☆	☆	☆	☆	☆	☆	☆	☆
102K							☆	☆	☆	☆	☆	☆	☆	☆	☆
112K							☆	☆	☆	☆	☆	☆	☆	☆	☆
122K											☆	☆		☆	☆
182K											☆			☆	

► Taping Specification for 05D & 07D

Straight Leads		Crimped Leads	
Symbol	Parameter (mm)	Element Diameter	
		05D	07D
P	Pitch of component	12.7±1.0	12.7±1.0
P <sub>0</sub>	Feed hole pitch	12.7±0.3	12.7±0.3
P <sub>1</sub>	Feed hole center to lead	3.85±0.7	3.85±0.7
P <sub>2</sub>	Hole center to component center	6.35±1.3	6.35±1.3
F	Lead to lead distance	5.0±0.8	5.0±0.8
h	Component alignment	0±2	0±2
W	Tape width	18.0±1.0	18.0±1.0
W <sub>0</sub>	Hold down tape width	12.0±1.0	12.0±1.0
W <sub>1</sub>	Hold position	9.0±0.5	9.0±0.5
W <sub>2</sub>	Hold down tape position	Max. 3.0	Max. 3.0
H <sub>0</sub>	Height from tape center to the bottom of crimp lead	16.0±1.0	16.0±1.0
H	Height from tape center to bottom of pant-leg	20.0±2.0	20.0±2.0
I	Length of clipped lead	Max. 1.0	Max. 1.0
D <sub>0</sub>	Feed hole diameter	4.0±0.2	4.0±0.2
t	Total tape thickness	0.6±0.3	0.6±0.3
B	Height from tape center to top of the component	Max. 32	Max. 32

► Taping Specification for 10D, 14D & 20D

Straight Leads		Crimped Leads		
Symbol	Parameter (mm)	Element Diameter		
		10D	14D	20D
P	Pitch of component	25.4±1.0	25.4±1.0	25.4±1.0
P <sub>0</sub>	Feed hole pitch	12.7±1.0	12.7±1.0	12.7±1.0
P <sub>1</sub>	Feed hole center to lead	8.95±0.7	8.95±0.7	7.7±0.7
P <sub>2</sub>	Hole center to component center	12.7±1.3	12.7±1.3	12.7±1.3
F	Lead to lead distance	7.5±0.8	7.5±0.8	10±0.8
h	Component alignment	0±2	0±4	0±4
W	Tape width	18.0±1.0	18.0±1.0	18.0±1.0
W <sub>0</sub>	Hold down tape width	12.0±1.0	12.0±1.0	12.0±1.0
W <sub>1</sub>	Hold position	9.0±0.5	9.0±0.5	9.0±0.5
W <sub>2</sub>	Hold down tape position	Max. 3.0	Max. 3.0	Max. 3.0
H <sub>0</sub>	Height from tape center to the bottom of crimped lead	16.0±1.0	16.0±1.0	16.0±1.0
H	Height from tape center to the bottom of pant-leg	20.0±2.0	20.0±2.0	20.0±2.0
I	Length of clipped lead	Max. 1.0	Max. 1.0	Max. 1.0
D <sub>0</sub>	Feed hole diameter	4.0±0.2	4.0±0.2	4.0±0.2
t	Total tape thickness	0.6±0.3	0.6±0.3	0.6±0.3
B	Height from tape center to the top of component	Max. 36	Max. 40	Max. 45

► Packaging

		Bulk Pack(straight / trimmed)		Tape & Reel	Ammo	Boxes / Carton
		Pcs / Bag	Bags / Box	Pcs / Box	Pcs / Box	
05D	180K~331K	1000	2	1500	1500	8
	361K~391K					
	431K~561K					
07D	180K~331K					
	361K~391K					
	431K~681K					
10D	180K~391K	500		750	750	
	431K~621K	400		N/A	N/A	
	681K~112K	300		N/A	N/A	
	182K					
14D	180K~331K	400		750	750	
	361K~621K	300		N/A	N/A	
	681K~112K	250				
	182K	150				
20D	180K~301K	250	N/A	N/A		
	331K~561K	200				
	621K~112K	150				
	182K	100				
25D	201K~621K	100	N/A	N/A		
	681K~122K	50				

## ►► 05D Specification

ZOV05D Part No.		Max. Allowable Voltage		Varistor Voltage		Max. Clamping Voltage		Max. Peak Current		Max. Energy		Rated Power (W)	Typical Capacitance @ 1 KHz (pf)	Max. Thickness (mm)	Certificate Status		
		Acrms (V)	DC (V)	V @ 1Ma (V)		VC (V)	IP (A)	@ 8/20µs	@ 10/1000µs (J)	UL	CSA				VDE		
180K	J	11	14	18	(15-21)	40	1	100	250	0.4	0.6	0.01	1400	4.5	⊙	⊙	⊙
220K	J	14	18	22	(20-24)	48	1	100	250	0.5	0.7	0.01	1150	4.6	⊙	⊙	⊙
270K	J	17	22	27	(24-30)	60	1	100	250	0.6	0.9	0.01	930	4.7	⊙	⊙	⊙
330K	J	20	26	33	(30-36)	73	1	100	250	0.8	1.1	0.01	760	4.9	⊙	⊙	⊙
390K	J	25	31	39	(35-43)	80	1	100	250	0.9	1.2	0.01	640	4.8	⊙	⊙	⊙
470K	J	30	38	47	(42-52)	104	1	100	250	1.1	1.5	0.01	530	4.9	⊙	⊙	⊙
560K	J	35	45	56	(50-62)	123	1	100	250	1.3	1.8	0.01	450	5.0	⊙	⊙	⊙
680K	J	40	56	68	(61-75)	150	1	100	250	1.6	2.2	0.01	370	5.2	⊙	⊙	⊙
820K	J	50	65	82	(74-90)	145	5	400	800	2.5	4.0	0.10	300	4.1	⊙	⊙	⊙
101K	J	60	85	100	(90-110)	175	5	400	800	3.0	4.1	0.10	250	4.3	⊙	⊙	⊙
121K	J	75	100	120	(108-132)	210	5	400	800	4.0	4.9	0.10	210	4.5	⊙	⊙	⊙
151K	J	95	125	150	(135-165)	260	5	400	800	4.8	6.5	0.10	165	4.8	⊙	⊙	⊙
181K	J	115	150	180	(162-198)	320	5	400	800	5.9	7.5	0.10	140	4.3	⊙	⊙	⊙
201K	J	130	170	200	(185-225)	355	5	400	800	6.5	8.5	0.10	125	4.4	⊙	⊙	⊙
221K	J	140	180	220	(198-242)	380	5	400	800	7.0	9.0	0.10	110	4.5	⊙	⊙	⊙
241K	J	150	200	240	(216-264)	415	5	400	800	8.0	10.5	0.10	100	4.6	⊙	⊙	⊙
271K	J	175	225	270	(243-297)	475	5	400	800	8.5	11.0	0.10	95	4.9	⊙	⊙	⊙
301K	J	190	250	300	(270-330)	520	5	400	800	9.0	12.0	0.10	85	5.0	⊙	⊙	⊙
331K	J	210	275	330	(297-363)	570	5	400	800	9.5	13.0	0.10	75	5.1	⊙	⊙	⊙
361K	J	230	300	360	(324-396)	620	5	400	800	10.0	16.0	0.10	70	5.2	⊙	⊙	⊙
391K	J	250	320	390	(351-429)	675	5	400	800	12.0	17.0	0.10	65	5.4	⊙	⊙	⊙
431K	J	275	350	430	(387-473)	745	5	400	800	13.0	20.0	0.10	60	5.7	⊙	⊙	⊙
471K	J	300	385	470	(423-517)	810	5	400	800	15.0	21.0	0.10	55	6.0	⊙	⊙	⊙
511K	J	320	415	510	(459-561)	845	5	400	800	16.0	22.5	0.10	50	6.2	⊙	⊙	⊙
561K	J	350	460	560	(504-616)	920	5	400	800	16.0	24.0	0.10	45	6.5	⊙	⊙	⊙

Note: Part no. with "J" represents high surge parts which values are highlighted in light blue.

## ► 07D Specification

ZOV07D Part No.		Max. Allowable Voltage		Varistor Voltage		Max. Clamping Voltage		Max. Peak Current		Max. Energy		Rated Power (W)	Typical Capacitance @ 1 KHz (pf)	Max. Thickness (mm)	Certificate Status		
		Acrms (V)	DC (V)	V @ 1Ma (V)		VC (V)	IP (A)	@ 8/20µs		@ 10/1000µs (J)					UL	CSA	VDE
180K	J	11	14	18	(15-21)	36	2.5	250	500	0.9	2.0	0.02	2800	4.5	⊙	⊙	⊙
220K	J	14	18	22	(20-24)	43	2.5	250	500	1.1	2.4	0.02	2300	4.6	⊙	⊙	⊙
270K	J	17	22	27	(24-30)	53	2.5	250	500	1.4	3.0	0.02	1800	4.7	⊙	⊙	⊙
330K	J	20	26	33	(30-36)	65	2.5	250	500	1.7	3.5	0.02	1500	4.9	⊙	⊙	⊙
390K	J	25	31	39	(35-43)	77	2.5	250	500	2.1	4.0	0.02	1300	4.8	⊙	⊙	⊙
470K	J	30	38	47	(42-52)	93	2.5	250	500	2.5	5.0	0.02	1100	4.9	⊙	⊙	⊙
560K	J	35	45	56	(50-62)	110	2.5	250	500	3.1	6.0	0.02	890	5.0	⊙	⊙	⊙
680K	J	40	56	68	(61-75)	135	2.5	250	500	3.6	7.0	0.02	740	5.2	⊙	⊙	⊙
820K	J	50	65	82	(74-90)	135	10	1200	1750	5.5	10	0.02	600	4.1	⊙	⊙	⊙
101K	J	60	85	100	(90-110)	165	10	1200	1750	6.5	12	0.25	500	4.3	⊙	⊙	⊙
121K	J	75	100	120	(108-132)	200	10	1200	1750	7.8	13	0.25	420	4.5	⊙	⊙	⊙
151K	J	95	125	150	(135-165)	250	10	1200	1750	9.7	13	0.25	330	4.8	⊙	⊙	⊙
181K	J	115	150	180	(162-198)	300	10	1200	1750	11.7	16	0.25	280	4.3	⊙	⊙	⊙
201K	J	130	170	200	(185-225)	340	10	1200	1750	13.0	17	0.25	250	4.4	⊙	⊙	⊙
221K	J	140	180	220	(198-242)	360	10	1200	1750	14.0	19	0.25	230	4.5	⊙	⊙	⊙
241K	J	150	200	240	(216-264)	395	10	1200	1750	15.0	21	0.25	210	4.6	⊙	⊙	⊙
271K	J	175	225	270	(243-297)	455	10	1200	1750	18.0	24	0.25	185	4.9	⊙	⊙	⊙
301K	J	190	250	300	(270-330)	500	10	1200	1750	20.0	26	0.25	165	5.0	⊙	⊙	⊙
331K	J	210	275	330	(297-363)	550	10	1200	1750	23.0	28	0.25	150	5.1	⊙	⊙	⊙
361K	J	230	300	360	(324-396)	595	10	1200	1750	25.0	32	0.25	140	5.2	⊙	⊙	⊙
391K	J	250	320	390	(351-429)	650	10	1200	1750	25.0	35	0.25	130	5.4	⊙	⊙	⊙
431K	J	275	350	430	(387-473)	710	10	1200	1750	28.0	40	0.25	115	5.7	⊙	⊙	⊙
471K	J	300	385	470	(423-517)	775	10	1200	1750	30.0	42	0.25	105	6.0	⊙	⊙	⊙
511K	J	320	415	510	(459-561)	845	10	1200	1750	30.0	45	0.25	100	6.2	⊙	⊙	⊙
561K	J	350	460	560	(504-616)	925	10	1200	1750	30.0	49	0.25	90	6.5	⊙	⊙	⊙
621K	J	385	505	620	(558-682)	1025	10	1200	1750	33.0	55	0.25	80	7.1	⊙	⊙	⊙
681K	J	420	560	680	(612-748)	1120	10	1200	1750	33.0	60	0.25	75	7.3	⊙	⊙	⊙

Note: Part no. with "J" represents high surge parts which values are highlighted in light blue.

►► 10D Specification

ZOV10D Part No.		Max. Allowable Voltage		Varistor Voltage		Max. Clamping Voltage		Max. Peak Current		Max. Energy		Rated Power (W)	Typical Capacitance @ 1 KHz (pf)	Max. Thickness (mm)	Certificate Status		
		Acrms (V)	DC (V)	V @ 1Ma (V)		VC (V)	IP (A)	@ 8/20µs		@ 10/1000µs (J)					UL	CSA	VDE
180K	J	11	14	18	(15-21)	36	5	500	1000	2.1	3.5	0.05	5600	4.6	⊗	⊗	⊗
220K	J	14	18	22	(20-24)	43	5	500	1000	2.5	5.0	0.05	4500	4.7	⊗	⊗	⊗
270K	J	17	22	27	(24-30)	53	5	500	1000	3.0	6.0	0.05	3700	4.8	⊗	⊗	⊗
330K	J	20	26	33	(30-36)	65	5	500	1000	4.0	7.0	0.05	3000	5.0	⊗	⊗	⊗
390K	J	25	31	39	(35-43)	77	5	500	1000	4.6	9.0	0.05	2400	5.3	⊗	⊗	⊗
470K	J	30	38	47	(42-52)	93	5	500	1000	5.5	11.0	0.05	2100	5.4	⊗	⊗	⊗
560K	J	35	45	56	(50-62)	110	5	500	1000	7.0	13.0	0.05	1800	5.5	⊗	⊗	⊗
680K	J	40	56	68	(61-75)	135	5	500	1000	8.2	15.0	0.05	1500	5.6	⊗	⊗	⊗
820K	J	50	65	82	(74-90)	135	25	2500	3500	12.0	17.0	0.40	1200	4.7	⊗	⊗	⊗
101K	J	60	85	100	(90-110)	165	25	2500	3500	15.0	18.0	0.40	1000	4.9	⊗	⊗	⊗
121K	J	75	100	120	(108-132)	200	25	2500	3500	18.0	21.0	0.40	830	5.1	⊗	⊗	⊗
151K	J	95	125	150	(135-165)	250	25	2500	3500	22.0	25.0	0.40	670	5.4	⊗	⊗	⊗
181K	J	115	150	180	(162-198)	300	25	2500	3500	27.0	30.0	0.40	560	4.8	⊗	⊗	⊗
201K	J	130	170	200	(185-225)	340	25	2500	3500	30.0	35.0	0.40	500	5.0	⊗	⊗	⊗
221K	J	140	180	220	(198-242)	360	25	2500	3500	32.0	39.0	0.40	450	5.1	⊗	⊗	⊗
241K	J	150	200	240	(216-264)	395	25	2500	3500	35.0	42.0	0.40	420	5.2	⊗	⊗	⊗
271K	J	175	225	270	(243-297)	455	25	2500	3500	40.0	49.0	0.40	370	5.4	⊗	⊗	⊗
301K	J	190	250	300	(270-330)	500	25	2500	3500	40.0	54.0	0.40	330	5.5	⊗	⊗	⊗
331K	J	210	275	330	(297-363)	550	25	2500	3500	43.0	58.0	0.40	300	5.8	⊗	⊗	⊗
361K	J	230	300	360	(324-396)	595	25	2500	3500	47.0	65.0	0.40	280	6.0	⊗	⊗	⊗
391K	J	250	320	390	(351-429)	650	25	2500	3500	60.0	70.0	0.40	260	6.2	⊗	⊗	⊗
431K	J	275	350	430	(387-473)	710	25	2500	3500	65.0	80.0	0.40	230	6.5	⊗	⊗	⊗
471K	J	300	385	470	(423-517)	775	25	2500	3500	70.0	85.0	0.40	210	6.7	⊗	⊗	⊗
511K	J	320	415	510	(459-561)	845	25	2500	3500	70.0	90.0	0.40	200	6.8	⊗	⊗	⊗
561K	J	350	460	560	(504-616)	925	25	2500	3500	70.0	92.0	0.40	180	7.0	⊗	⊗	⊗
621K	J	385	505	620	(558-682)	1025	25	2500	3500	70.0	95.0	0.40	160	7.3	⊗	⊗	⊗
681K	J	420	560	680	(612-748)	1120	25	2500	3500	70.0	98.0	0.40	150	7.6	⊗	⊗	⊗
751K	J	460	615	750	(675-825)	1240	25	2500	3500	75.0	100.0	0.40	130	8.0	⊗	⊗	⊗
781K	J	485	640	780	(702-858)	1290	25	2500	3500	80.0	105.0	0.40	130	8.1	⊗	⊗	⊗
821K	J	510	670	820	(738-902)	1355	25	2500	3500	85.0	110.0	0.40	120	8.3	⊗	⊗	⊗
911K	J	550	745	910	(819-1001)	1500	25	2500	3500	93.0	130.0	0.40	110	8.8	⊗	⊗	⊗
102K	J	625	825	1000	(900-1100)	1650	25	2500	3500	102.0	140.0	0.40	100	9.3	⊗	⊗	⊗
112K	J	680	895	1100	(990-1210)	1815	25	2500	3500	115.0	155.0	0.40	90	9.9	⊗	⊗	⊗

Note: Part no. with "J" represents high surge parts which values are highlighted in light blue.

► 14D Specification

ZOV14D Part No.		Max. Allowable Voltage		Varistor Voltage		Max. Clamping Voltage		Max. Peak Current		Max. Energy		Rated Power (W)	Typical Capacitance @ 1 KHz (pf)	Max. Thickness (mm)	Certificate Status		
		Acrms (V)	DC (V)	V @ 1Ma (V)		VC (V)	IP (A)	@ 8/20µs		@ 10/1000µs (J)					UL	CSA	VDE
180K	J	11	14	18	(15-21)	36	10	1000	2000	4	7	0.1	11100	4.6	⊙	⊙	⊙
220K	J	14	18	22	(20-24)	43	10	1000	2000	5	8	0.1	9100	4.7	⊙	⊙	⊙
270K	J	17	22	27	(24-30)	53	10	1000	2000	6	10	0.1	7400	4.8	⊙	⊙	⊙
330K	J	20	26	33	(30-36)	65	10	1000	2000	7	12	0.1	6100	5.0	⊙	⊙	⊙
390K	J	25	31	39	(35-43)	77	10	1000	2000	8	13	0.1	5100	5.3	⊙	⊙	⊙
470K	J	30	38	47	(42-52)	93	10	1000	2000	10	17	0.1	4300	5.4	⊙	⊙	⊙
560K	J	35	45	56	(50-62)	110	10	1000	2000	11	20	0.1	3600	5.5	⊙	⊙	⊙
680K	J	40	56	68	(61-75)	135	10	1000	2000	14	24	0.1	2900	5.6	⊙	⊙	⊙
820K	J	50	65	82	(74-90)	135	50	4500	6000	22	27	0.6	2400	4.7	⊙	⊙	⊙
101K	J	60	85	100	(90-110)	165	50	4500	6000	28	33	0.6	2000	4.9	⊙	⊙	⊙
121K	J	75	100	120	(108-132)	200	50	4500	6000	32	40	0.6	1700	5.1	⊙	⊙	⊙
151K	J	95	125	150	(135-165)	250	50	4500	6000	40	53	0.6	1300	5.4	⊙	⊙	⊙
181K	J	115	150	180	(162-198)	300	50	4500	6000	50	60	0.6	1100	4.8	⊙	⊙	⊙
201K	J	130	170	200	(185-225)	340	50	4500	6000	57	70	0.6	1000	5.0	⊙	⊙	⊙
221K	J	140	180	220	(198-242)	360	50	4500	6000	60	78	0.6	900	5.1	⊙	⊙	⊙
241K	J	150	200	240	(216-264)	395	50	4500	6000	63	84	0.6	830	5.2	⊙	⊙	⊙
271K	J	175	225	270	(243-297)	455	50	4500	6000	70	99	0.6	740	5.4	⊙	⊙	⊙
301K	J	190	250	300	(270-330)	500	50	4500	6000	77	108	0.6	670	5.5	⊙	⊙	⊙
331K	J	210	275	330	(297-363)	550	50	4500	6000	85	115	0.6	610	5.8	⊙	⊙	⊙
361K	J	230	300	360	(324-396)	595	50	4500	6000	93	130	0.6	560	6.0	⊙	⊙	⊙
391K	J	250	320	390	(351-429)	650	50	4500	6000	100	140	0.6	510	6.2	⊙	⊙	⊙
431K	J	275	350	430	(387-473)	710	50	4500	6000	115	155	0.6	460	6.5	⊙	⊙	⊙
471K	J	300	385	470	(423-517)	775	50	4500	6000	125	175	0.6	430	6.7	⊙	⊙	⊙
511K	J	320	415	510	(459-561)	845	50	4500	6000	125	180	0.6	390	6.8	⊙	⊙	⊙
561K	J	350	460	560	(504-616)	925	50	4500	6000	125	185	0.6	360	7.0	⊙	⊙	⊙
621K	J	385	505	620	(558-682)	1025	50	4500	6000	125	190	0.6	320	7.3	⊙	⊙	⊙
681K	J	420	560	680	(612-748)	1120	50	4500	6000	130	200	0.6	290	7.6	⊙	⊙	⊙
751K	J	460	615	750	(675-825)	1240	50	4500	6000	143	210	0.6	270	8.0	⊙	⊙	⊙
781K	J	485	640	780	(702-858)	1290	50	4500	6000	148	220	0.6	260	8.1	⊙	⊙	⊙
821K	J	510	670	820	(738-902)	1355	50	4500	6000	157	235	0.6	240	8.3	⊙	⊙	⊙
911K	J	550	745	910	(819-1001)	1500	50	4500	6000	175	255	0.6	220	8.8	⊙	⊙	⊙
102K	J	625	825	1000	(900-1100)	1650	50	4500	6000	190	280	0.6	200	9.3	⊙	⊙	⊙
112K	J	680	895	1100	(990-1210)	1815	50	4500	6000	213	310	0.6	180	9.9	⊙	⊙	⊙
122K	J	750	990	1200	(1080-1320)	1980	50	4500	6000	213	310	0.6	150	10.4		⊙	⊙
182K	J	1100	146	1800	(1620-1980)	2970	50	5000	6000	250	335	0.6	130	13.0		⊙	

Note: Part no. with "J" represents high surge parts which values are highlighted in light blue.

## ►► 20D Specification

ZOV20D Part No.		Max. Allowable Voltage		Varistor Voltage		Max. Clamping Voltage		Max. Peak Current		Max. Energy		Rated Power (W)	Typical Capacitance @ 1 KHz (pf)	Max. Thickness (mm)	Certificate Status		
		Acrms (V)	DC (V)	V @ 1Ma (V)		VC (V)	IP (A)	@ 8/20µs		@ 10/1000µs (J)					UL	CSA	VDE
180K	J	11	14	18	(15-21)	36	20	2000	3000	11	13	0.2	28500	4.8	⊙	⊙	⊙
220K	J	14	18	22	(20-24)	43	20	2000	3000	14	16	0.2	18500	4.9	⊙	⊙	⊙
270K	J	17	22	27	(24-30)	53	20	2000	3000	16	19	0.2	13000	5.0	⊙	⊙	⊙
330K	J	20	26	33	(30-36)	65	20	2000	3000	23	24	0.2	11500	5.2	⊙	⊙	⊙
390K	J	25	31	39	(35-43)	77	20	2000	3000	26	28	0.2	8500	5.5	⊙	⊙	⊙
470K	J	30	38	47	(42-52)	93	20	2000	3000	30	34	0.2	7400	5.6	⊙	⊙	⊙
560K	J	35	45	56	(50-62)	110	20	2000	3000	41	41	0.2	6500	5.7	⊙	⊙	⊙
680K	J	40	56	68	(61-75)	135	20	2000	3000	46	49	0.2	5800	5.8	⊙	⊙	⊙
820K	J	50	65	82	(74-90)	135	100	6500	10000	38	56	1.0	4900	4.9	⊙	⊙	⊙
101K	J	60	85	100	(90-110)	165	100	6500	10000	45	70	1.0	4000	5.1	⊙	⊙	⊙
121K	J	75	100	120	(108-132)	200	100	6500	10000	55	85	1.0	3300	5.3	⊙	⊙	⊙
151K	J	95	125	150	(135-165)	250	100	6500	10000	70	106	1.0	2700	5.6	⊙	⊙	⊙
181K	J	115	150	180	(162-198)	300	100	6500	10000	85	130	1.0	2200	5.0	⊙	⊙	⊙
201K	J	130	170	200	(185-225)	340	100	6500	10000	95	140	1.0	2000	5.2	⊙	⊙	⊙
221K	J	140	180	220	(198-242)	360	100	6500	10000	100	155	1.0	1800	5.3	⊙	⊙	⊙
241K	J	150	200	240	(216-264)	395	100	6500	10000	108	168	1.0	1650	5.4	⊙	⊙	⊙
271K	J	175	225	270	(243-297)	455	100	6500	10000	127	190	1.0	1500	5.6	⊙	⊙	⊙
301K	J	190	250	300	(270-330)	500	100	6500	10000	136	210	1.0	1300	5.7	⊙	⊙	⊙
331K	J	210	275	330	(297-363)	550	100	6500	10000	150	228	1.0	1200	6.0	⊙	⊙	⊙
361K	J	230	300	360	(324-396)	595	100	6500	10000	163	255	1.0	1100	6.2	⊙	⊙	⊙
391K	J	250	320	390	(351-429)	650	100	6500	10000	180	275	1.0	1000	6.4	⊙	⊙	⊙
431K	J	275	350	430	(387-473)	710	100	6500	10000	190	305	1.0	930	6.7	⊙	⊙	⊙
471K	J	300	385	470	(423-517)	775	100	6500	10000	220	350	1.0	850	6.9	⊙	⊙	⊙
511K	J	320	415	510	(459-561)	845	100	6500	1000	220	360	1.0	780	7.0	⊙	⊙	⊙
561K	J	350	460	560	(504-616)	925	100	6500	1000	220	380	1.0	710	7.2	⊙	⊙	⊙
621K	J	385	505	620	(558-682)	1025	100	6500	1000	220	390	1.0	650	7.5	⊙	⊙	⊙
681K	J	420	560	680	(612-748)	1120	100	6500	10000	230	400	1.0	600	7.8	⊙	⊙	⊙
751K	J	460	615	750	(675-825)	1240	100	6500	10000	255	420	1.0	530	8.2	⊙	⊙	⊙
781K	J	485	640	780	(702-858)	1290	100	6500	10000	265	440	1.0	510	8.3	⊙	⊙	⊙
821K	J	510	670	820	(738-902)	1355	100	6500	10000	282	460	1.0	500	8.5	⊙	⊙	⊙
911K	J	550	745	910	(819-1001)	1500	100	6500	10000	310	510	1.0	440	9.0	⊙	⊙	⊙
102K	J	625	825	1000	(900-1100)	1650	100	6500	10000	342	565	1.0	400	9.5	⊙	⊙	⊙
112K	J	680	895	1100	(990-1210)	1815	100	6500	10000	383	620	1.0	360	10.1	⊙	⊙	⊙
122K	J	750	990	1200	(1080-1320)	1980	100	6500	10000	408	660	1.0	320	10.6		⊙	⊙
182K	J	1100	1465	1800	(1620-1980)	2970	100	6500	10000	625	660	1.0	320	13.2		⊙	

Note: Part no. with "J" represents high surge parts which values are highlighted in light blue.

► 25D Specification

ZOV25D Part No.		Max. Allowable Voltage		Varistor Voltage		Max. Clamping Voltage		Max. Peak Current		Max. Energy		Rated Power (W)	Typical Capacitance @ 1 KHz (pf)	Max. Thickness (mm)	Certificate Status		
		Acrms (V)	DC (V)	V @ 1Ma (V)		VC (V)	IP (A)	@ 8/20µs		@ 10/1000µs (J)					UL	CSA	VDE
180K	J	11	14	18	(15-21)	36	30	3000	4500	13	20	0.25	45000	4.8		⊗	⊗
220K	J	14	18	22	(20-24)	43	30	3000	4500	16	25	0.25	29000	4.9		⊗	⊗
270K	J	17	22	27	(24-30)	53	30	3000	4500	19	30	0.25	26500	5.0		⊗	⊗
330K	J	20	26	33	(30-36)	65	30	3000	4500	24	35	0.25	18000	5.2		⊗	⊗
390K	J	25	31	39	(35-43)	77	30	3000	4500	28	40	0.25	13500	5.5		⊗	⊗
470K	J	30	38	47	(42-52)	93	30	3000	4500	34	50	0.25	11500	5.6		⊗	⊗
560K	J	35	45	56	(50-62)	110	30	3000	4500	41	60	0.25	10500	5.7		⊗	⊗
680K	J	40	56	68	(61-75)	135	30	3000	4500	49	70	0.25	9050	5.8		⊗	⊗
820K	J	50	65	82	(74-90)	135	30	3000	4500	56	80	0.25	7700	4.9		⊗	⊗
101K	J	60	85	100	(90-110)	165	150	15000	18000	70	100	1.20	6300	5.1		⊗	⊗
121K	J	75	100	120	(108-132)	200	150	15000	18000	85	120	1.20	5200	5.3		⊗	⊗
151K	J	95	125	150	(135-165)	250	150	15000	18000	106	160	1.20	4300	5.6		⊗	⊗
181K	J	115	150	180	(162-198)	300	150	15000	18000	130	175	1.20	3500	5.2		⊗	⊗
201K	J	130	170	200	(185-225)	340	150	15000	18000	140	190	1.20	3200	5.4	⊗	⊗	⊗
221K	J	140	180	220	(198-242)	360	150	15000	18000	155	200	1.20	2900	5.5	⊗	⊗	⊗
241K	J	150	200	240	(216-264)	395	150	15000	18000	168	220	1.20	2650	5.6	⊗	⊗	⊗
271K	J	175	225	270	(243-297)	455	150	15000	18000	190	255	1.20	2400	5.8	⊗	⊗	⊗
301K	J	190	250	300	(270-330)	500	150	15000	18000	210	275	1.20	2100	5.9	⊗	⊗	⊗
331K	J	210	275	330	(297-363)	550	150	15000	18000	228	300	1.20	1900	6.1	⊗	⊗	⊗
361K	J	230	300	360	(324-396)	595	150	15000	18000	255	330	1.20	1750	6.4	⊗	⊗	⊗
391K	J	250	320	390	(351-429)	650	150	15000	18000	275	360	1.20	1600	6.6	⊗	⊗	⊗
431K	J	275	350	430	(387-473)	710	150	15000	18000	305	380	1.20	1500	6.9	⊗	⊗	⊗
471K	J	300	385	470	(423-517)	775	150	15000	18000	350	400	1.20	1400	7.1	⊗	⊗	⊗
511K	J	320	415	510	(459-561)	845	150	15000	18000	382	420	1.20	1250	7.2	⊗	⊗	⊗
561K	J	350	460	560	(504-616)	925	150	15000	18000	380	440	1.20	1150	7.4	⊗	⊗	⊗
621K	J	385	505	620	(558-682)	1025	150	15000	18000	380	450	1.20	1050	7.7	⊗	⊗	⊗
681K	J	420	560	680	(612-748)	1120	150	15000	18000	380	460	1.20	950	8.0	⊗	⊗	⊗
751K	J	460	615	750	(675-825)	1240	150	15000	18000	380	510	1.20	850	8.4	⊗	⊗	⊗
781K	J	485	640	780	(702-858)	1290	150	15000	18000	440	530	1.20	800	8.5	⊗	⊗	⊗
821K	J	510	670	820	(738-902)	1355	150	15000	18000	460	570	1.20	750	8.7	⊗	⊗	⊗
911K	J	550	745	910	(819-1001)	1500	150	15000	18000	510	620	1.20	700	9.2	⊗	⊗	⊗
102K	J	625	825	1000	(900-1100)	1650	150	15000	18000	565	685	1.20	650	9.7	⊗	⊗	⊗
112K	J	680	895	1100	(990-1210)	1815	150	15000	18000	620	770	1.20	600	10.3	⊗	⊗	⊗
122K	J	750	990	1200	(1080-1320)	1980	150	15000	18000	631	770	1.20	550	10.8		⊗	⊗
142K	J	880	1140	1400	(1260-1540)	2310	150	15000	18000	697	850	1.20	500	-		⊗	
162K	J	1000	1280	1600	(1440-1760)	2640	150	15000	18000	805	970	1.20	450	-		⊗	

Note: Part no. with "J" represents high surge parts which values are highlighted in light blue.

►► 32D Specification

ZOV32D Part No.	Max. Allowable Voltage		Varistor Voltage		Max. Clamping Voltage		Max. Peak Current @ 8/20µs		Max. Energy @ 10/1000µs	Typical Capacitance	Max. Thickness	Certificate Status	
	Acrms (V)	DC (V)	V @ 1Ma (V)		VC (V)	IP (A)	1 time (A)	2 times (A)	@10/1000µs (J)	@ 1 KHz (pf)	(mm)	UL	CSA
201K	130	170	200	(185-225)	340	200	25000	20000	250	5200	6.2	⊙	⊙
221K	140	180	220	(198-242)	395	200	25000	20000	290	5100	6.4	⊙	⊙
241K	150	200	240	(216-264)	455	200	25000	20000	300	4800	6.6	⊙	⊙
271K	175	225	270	(243-297)	550	200	25000	20000	360	4300	6.9	⊙	⊙
331K	210	275	330	(297-363)	595	200	25000	20000	380	3900	7.1	⊙	⊙
361K	230	300	360	(324-396)	650	200	25000	20000	400	3200	7.3	⊙	⊙
391K	250	320	390	(351-429)	710	200	25000	20000	430	3100	7.5	⊙	⊙
431K	275	350	430	(387-473)	775	200	25000	20000	460	2800	7.8	⊙	⊙
471K	300	385	470	(423-517)	845	200	25000	20000	510	2700	8.0	⊙	⊙
511K	320	415	510	(459-561)	1025	200	25000	20000	570	2400	8.7	⊙	⊙
621K	385	505	620	(558-682)	1120	200	25000	20000	600	2200	9.0	⊙	⊙
681K	420	560	680	(612-748)	1240	200	25000	20000	620	2000	9.4	⊙	⊙
751K	460	615	750	(675-825)	1290	200	25000	20000	660	1900	9.6	⊙	⊙
781K	485	640	780	(702-858)	1355	200	25000	20000	700	1800	9.8	⊙	⊙
821K	510	670	820	(738-902)	1500	200	25000	20000	750	1300	10.4	⊙	⊙
911K	550	745	910	(819-1001)	1570	200	25000	20000	780	1200	10.6	⊙	⊙
102K	625	825	1000	(900-1100)	1650	200	25000	20000	810	1100	11.2	⊙	⊙
112K	680	895	1100	(990-1210)	1815	200	25000	20000	910	1000	11.8	⊙	⊙
122K	750	990	1200	(1080-1320)	1980	200	25000	20000	960	920	12.3		⊙
142K	880	1140	1400	(1260-1540)	2310	200	25000	20000	1020	800	13.3		⊙
162K	1000	1280	1600	(1440-1760)	2640	200	25000	20000	1080	700	14.3		⊙

►► 32D Dimension

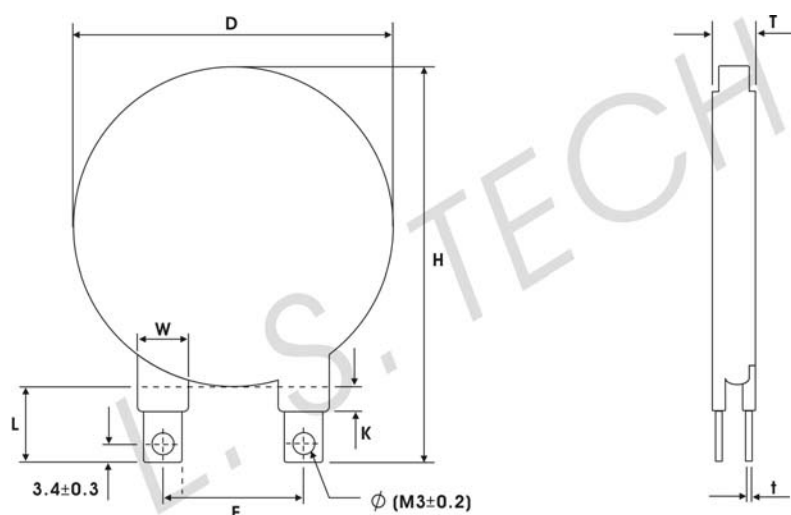

D	38.0	Max.
H	56.3	Max.
T	See above chart	Max.
F	25.4	±0.5
t	0.5	±0.1
L	16.5	Min.
K	3.18	Max.
W	7.0	±0.5
φ	3.8	M3±0.2

► 40D Specification

ZOV40D Part No.	Max. Allowable Voltage		Varistor Voltage		Max. Clamping Voltage		Max. Peak Current @ 8/20µs		Max. Energy @ 10/1000µs	Typical Capacitance	Max. Thickness	Certificate Status	
	Acrms (V)	DC (V)	V @ 1Ma (V)		VC (V)	IP (A)	1 time (A)	2 times (A)	@10/1000µs (J)	@ 1 KHz (pf)	(mm)	UL	CSA
201K	130	170	200	(185-225)	340	300	40000	30000	370	8400	6.2	⊙	⊙
241K	150	200	240	(216-264)	395	300	40000	30000	430	8000	6.4	⊙	⊙
271K	175	225	270	(243-297)	455	300	40000	30000	470	7600	6.6	⊙	⊙
331K	210	275	330	(297-363)	550	300	40000	30000	550	6700	6.9	⊙	⊙
361K	230	300	360	(324-396)	595	300	40000	30000	570	6200	7.1	⊙	⊙
391K	250	320	390	(351-429)	650	300	40000	30000	590	5100	7.3	⊙	⊙
431K	275	350	430	(387-473)	710	300	40000	30000	660	4900	7.5	⊙	⊙
471K	300	385	470	(423-517)	775	300	40000	30000	720	4300	7.8	⊙	⊙
511K	320	415	510	(459-561)	845	300	40000	30000	770	4200	8.0	⊙	⊙
621K	385	505	620	(558-682)	1025	300	40000	30000	860	3800	8.7	⊙	⊙
681K	420	560	680	(612-748)	1120	300	40000	30000	900	3500	9.0	⊙	⊙
751K	460	615	750	(675-825)	1240	300	40000	30000	940	3200	9.4	⊙	⊙
781K	485	640	780	(702-858)	1290	300	40000	30000	980	3000	9.6	⊙	⊙
821K	510	670	820	(738-902)	1355	300	40000	30000	1080	2900	9.8	⊙	⊙
911K	550	745	910	(819-1001)	1500	300	40000	30000	1150	2200	10.4	⊙	⊙
951K	575	765	950	(855-1045)	1570	300	40000	30000	1200	2000	10.6	⊙	⊙
102K	625	825	1000	(900-1100)	1650	300	40000	30000	1260	1800	11.2	⊙	⊙
112K	680	895	1100	(990-1210)	1815	300	40000	30000	1380	1600	11.8	⊙	⊙
122K	750	990	1200	(1080-1320)	1980	300	40000	30000	1380	1500	12.3		⊙
142K	880	1140	1400	(1260-1540)	2310	300	40000	30000	1550	1300	13.3		⊙
162K	1000	1280	1600	(1440-1760)	2640	300	40000	30000	1700	1150	14.3		⊙

► 40D Dimension

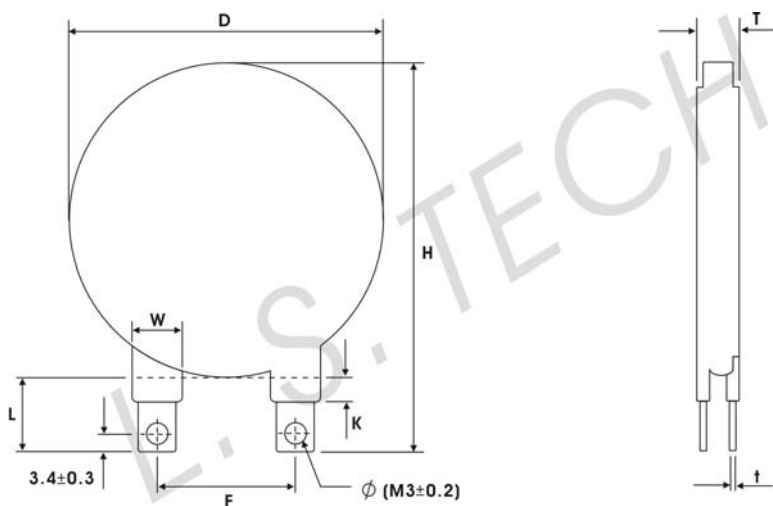

D	45.0	Max.
H	60.2	Max.
T	See above chart	Max.
F	25.4	±0.5
t	0.5	±0.1
L	16.5	Min.
K	3.18	Max.
W	7.0	±0.5
φ	3.8	M3±0.2

►► 53D Specification

ZOV40D Part No.	Max. Allowable Voltage		Varistor Voltage		Max. Clamping Voltage		Max. Peak Current @ 8/20µs		Max. Energy @ 10/1000µs	Typical Capacitance	Max. Thickness	Certificate Status	
	Acrms (V)	DC (V)	V @ 1Ma (V)		VC (V)	IP (A)	1 time (A)	2 times (A)	@10/1000µs (J)	@ 1 KHz (pf)	(mm)	UL	CSA
201K	130	170	200	(185-225)	340	500	70000	50000	550	15000	6.3	⊙	⊙
241K	150	200	240	(216-264)	395	500	70000	50000	650	12500	6.5	⊙	⊙
271K	175	225	270	(243-297)	455	500	70000	50000	700	1000	6.7	⊙	⊙
331K	210	275	330	(297-363)	550	500	70000	50000	825	9000	7.0	⊙	⊙
361K	230	300	360	(324-396)	595	500	70000	50000	850	8500	7.2	⊙	⊙
391K	250	320	390	(351-429)	650	500	70000	50000	885	7500	7.4	⊙	⊙
431K	275	350	430	(387-473)	710	500	70000	50000	990	7000	7.6	⊙	⊙
471K	300	385	470	(423-517)	775	500	70000	50000	1080	6500	7.9	⊙	⊙
511K	320	415	510	(459-561)	845	500	70000	50000	1150	6000	8.1	⊙	⊙
621K	385	505	620	(558-682)	1025	500	70000	50000	1300	5000	8.8	⊙	⊙
681K	420	560	680	(612-748)	1120	500	70000	50000	1350	4500	9.1	⊙	⊙
751K	460	615	750	(675-825)	1240	500	70000	50000	1400	4000	9.5	⊙	⊙
781K	485	640	780	(702-858)	1290	500	70000	50000	1400	3900	9.7	⊙	⊙
821K	510	670	820	(738-902)	1355	500	70000	50000	1600	3700	9.9	⊙	⊙
911K	550	745	910	(819-1001)	1500	500	70000	50000	1700	3300	10.5	⊙	⊙
951K	575	765	950	(855-1045)	1570	500	70000	50000	1800	3200	10.7	⊙	⊙
102K	625	825	1000	(900-1100)	1650	500	70000	50000	1890	3000	11.3	⊙	⊙
112K	680	895	1100	(990-1210)	1815	500	70000	50000	2050	2700	11.9	⊙	⊙
122K	750	990	1200	(1080-1320)	1980	500	70000	50000	2050	2500	12.4	⊙	⊙
142K	880	1140	1400	(1260-1540)	2310	500	70000	50000	2300	2150	13.4		⊙
162K	1000	1280	1600	(1440-1760)	2640	500	70000	50000	2500	1900	14.4		⊙

►► 53D Dimension

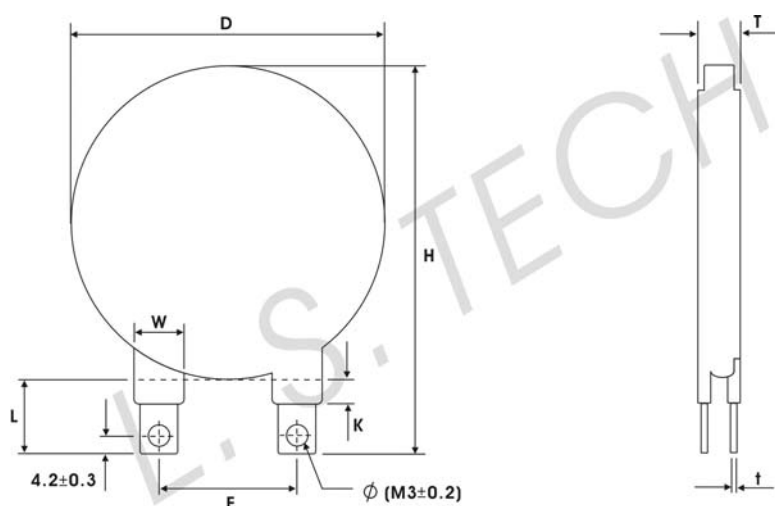

D	60.0	Max.
H	78.2	Max.
T	See above chart	Max.
F	25.4	±0.5
t	0.7	±0.1
L	16.5	Min.
K	3.18	Max.
W	9.7	±0.5
φ	4.15	M3±0.2

►► 34S Specification

ZOV34S Part No.	Max. Allowable Voltage		Varistor Voltage		Max. Clamping Voltage		Max. Peak Current @ 8/20µs		Max. Energy @ 10/1000µs	Typical Capacitance	Max. Thickness	Certificate Status	
	Acrms (V)	DC (V)	V @ 1Ma (V)		VC (V)	IP (A)	1 time (A)	2 times (A)	@10/1000µs (J)	@ 1 KHz (pf)	(mm)	UL	CSA
201K	130	170	200	(185-225)	340	300	40000	30000	330	8000	6.2	⊗	⊗
221K	140	180	220	(198-242)	360	300	40000	30000	360	7800	6.3	⊗	⊗
241K	150	200	240	(216-264)	395	300	40000	30000	390	7600	6.4	⊗	⊗
271K	175	225	270	(243-297)	455	300	40000	30000	420	7200	6.6	⊗	⊗
331K	210	275	330	(297-363)	550	300	40000	30000	500	6400	6.9	⊗	⊗
361K	230	300	360	(324-396)	595	300	40000	30000	510	6000	7.1	⊗	⊗
391K	250	320	390	(351-429)	650	300	40000	30000	530	4800	7.3	⊗	⊗
431K	275	350	430	(387-473)	710	300	40000	30000	600	4600	7.5	⊗	⊗
471K	300	385	470	(423-517)	775	300	40000	30000	650	4100	7.8	⊗	⊗
511K	320	415	510	(459-561)	845	300	40000	30000	700	4000	8.0	⊗	⊗
561K	350	460	560	(504-616)	925	300	40000	30000	730	3800	8.3	⊗	⊗
621K	385	505	620	(558-682)	1025	300	40000	30000	780	3600	8.7	⊗	⊗
681K	420	560	680	(612-748)	1120	300	40000	30000	810	3300	9.0	⊗	⊗
751K	460	615	750	(675-825)	1240	300	40000	30000	850	3000	9.4	⊗	⊗
781K	485	640	780	(702-858)	1290	300	40000	30000	930	2850	9.6	⊗	⊗
821K	510	670	820	(738-902)	1355	300	40000	30000	970	2700	9.8	⊗	⊗
911K	550	745	910	(819-1001)	1500	300	40000	30000	1050	2100	10.4	⊗	⊗
951K	575	765	950	(855-1045)	1570	300	40000	30000	1080	1900	10.6	⊗	⊗
102K	625	825	1000	(900-1100)	1650	300	40000	30000	1120	1700	11.2	⊗	⊗
112K	680	895	1100	(990-1210)	1815	300	40000	30000	1250	1520	11.8	⊗	⊗
122K	750	990	1200	(1080-1320)	1980	300	40000	30000	1250	1400	12.3		⊗
142K	880	1140	1400	(1260-1540)	2310	300	40000	30000	1400	1250	13.3		⊗
162K	1000	1280	1600	(1440-1760)	2640	300	40000	30000	1500	1100	14.3		⊗

►► 34S Dimension

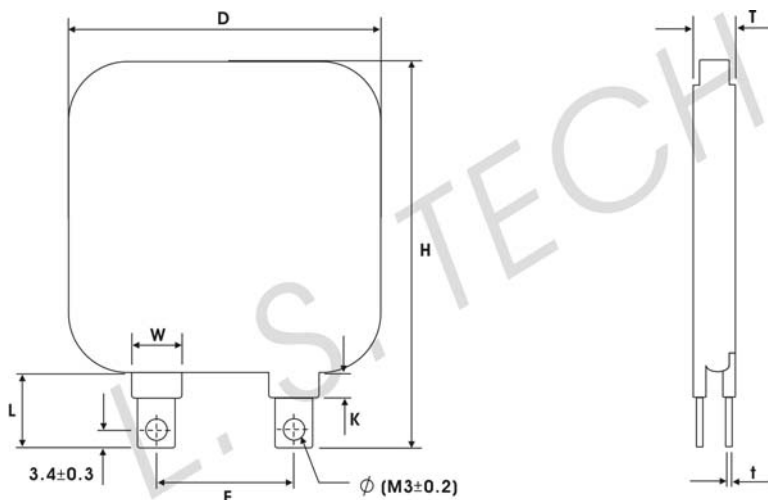

D	44.0	Max.
H	56.6	Max.
T	See above chart	Max.
F	25.4	±0.5
t	0.5	±0.1
L	16.5	Min.
K	3.18	Max.
W	7.0	±0.5
φ	3.8	M3±0.2

►► 34S Dual-discs Specification

ZOV34S Part No.	Max. Allowable Voltage		Varistor Voltage		Max. Clamping Voltage		Single Side Max. Peak Current @ 8/20µs		Max. Energy @ 10/1000µs	Typical Capacitance	Certifications
	Acrms (V)	DC (V)	V @ 1Ma (V)		VC (V)	IP (A)	1 time (A)	2 times (A)	@10/1000µs (J)	@ 1 KHz (pf)	UL
201KD	130	170	200	(185-225)	340	300	40000	30000	310	-	⊙
221KD	140	180	220	(198~242)	360	300	40000	30000	330	-	⊙
241KD	150	200	240	(216-264)	395	300	40000	30000	360	-	⊙
271KD	175	225	270	(243-297)	455	300	40000	30000	390	-	⊙
331KD	210	275	330	(297-363)	550	300	40000	30000	410	-	⊙
361KD	230	300	360	(324-396)	595	300	40000	30000	460	-	⊙
391KD	250	320	390	(351-429)	650	300	40000	30000	490	-	⊙
431KD	275	350	430	(387-473)	710	300	40000	30000	550	-	⊙
471KD	300	385	470	(423-517)	775	300	40000	30000	600	-	⊙
511KD	320	415	510	(459-561)	845	300	40000	30000	640	-	⊙
561KD	350	460	560	(504~616)	920	300	40000	30000	710	-	⊙
621KD	385	505	620	(558-682)	1025	300	40000	30000	800	-	⊙
681KD	420	560	680	(612-748)	1120	300	40000	30000	910	-	⊙
751KD	460	615	750	(675-825)	1240	300	40000	30000	980	-	⊙
781KD	485	640	780	(702-858)	1290	300	40000	30000	1020	-	⊙
821KD	510	670	820	(738-902)	1355	300	40000	30000	1100	-	⊙
911KD	550	745	910	(819-1001)	1500	300	40000	30000	1150	-	⊙
951KD	575	765	950	(855-1045)	1570	300	40000	30000	1200	-	⊙
102KD	625	825	1000	(900-1100)	1650	300	40000	30000	1250	-	⊙
112KD	680	895	1100	(990-1210)	1815	300	40000	30000	1350	-	⊙

►► 34S Dual-discs Dimension

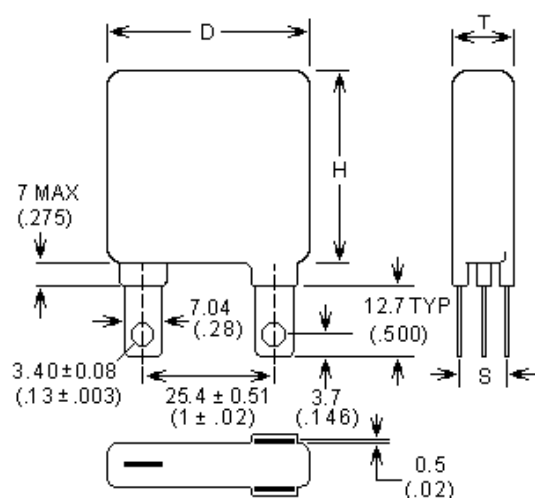

34S Dual-Discs Part Number	D max.	H max.	T max.	S
	mm	mm	mm	mm
201KD	42.0	42.0	7.5	2.5±1.0
221KD	42.0	42.0	7.5	2.5±1.0
241KD	42.0	42.0	7.5	2.8±1.0
271KD	42.0	42.0	8.5	2.8±1.0
331KD	42.0	42.0	9.0	3.1±1.0
361KD	42.0	42.0	9.0	3.3±1.0
391KD	42.0	42.0	9.0	3.6±1.0
431KD	42.0	42.0	9.0	3.6±1.0
471KD	42.0	42.0	9.7	3.8±1.0
511KD	42.0	42.0	9.7	3.8±1.0
561KD	42.0	42.0	9.7	4.3±1.0
621KD	42.0	42.0	9.7	4.6±1.0
681KD	42.0	42.0	10.5	4.8±1.0
751KD	42.0	42.0	10.5	4.8±1.0
781KD	42.0	42.0	10.5	5.1±1.0
821KD	42.0	42.0	11.5	5.6±1.0
911KD	42.0	42.0	11.5	5.6±1.0
951KD	42.0	42.0	12	5.8±1.0
102KD	42.0	42.0	12	6.4±1.0
112KD	42.0	42.0	12	6.4±1.0

► **Block Type - 34B Specification**

ZOV34B Part No.	Max. Allowable Voltage		Varistor Voltage		Max. Clamping Voltage		Max. Peak Current @ 8/20µs		Max. Energy @ 10/1000µs	Typical Capacitance
	Acrms (V)	DC (V)	V @ 1Ma (V)		VC (V)	IP (A)	1 time (A)	2 times (A)	@10/1000µs (J)	@ 1 KHz (pf)
201K	130	170	200	(185-225)	340	300	40000	30000	330	8000
221K	140	180	220	(198-242)	360	300	40000	30000	360	7800
241K	150	200	240	(216-264)	395	300	40000	30000	390	7600
271K	175	225	270	(243-297)	455	300	40000	30000	420	7200
331K	210	275	330	(297-363)	550	300	40000	30000	500	6400
361K	230	300	360	(324-396)	595	300	40000	30000	510	6000
391K	250	320	390	(351-429)	650	300	40000	30000	530	4800
431K	275	350	430	(387-473)	710	300	40000	30000	600	4600
471K	300	385	470	(423-517)	775	300	40000	30000	650	4100
511K	320	415	510	(459-561)	845	300	40000	30000	700	4000
561K	350	460	560	(504-616)	925	300	40000	30000	730	3800
621K	385	505	620	(558-682)	1025	300	40000	30000	780	3600
681K	420	560	680	(612-748)	1120	300	40000	30000	810	3300
751K	460	615	750	(675-825)	1240	300	40000	30000	850	3000
781K	485	640	780	(702-858)	1290	300	40000	30000	930	2850
821K	510	670	820	(738-902)	1355	300	40000	30000	970	2700
911K	550	745	910	(819-1001)	1500	300	40000	30000	1050	2100
951K	575	765	950	(855-1045)	1570	300	40000	30000	1080	1900
102K	625	825	1000	(900-1100)	1650	300	40000	30000	1120	1700
112K	680	895	1100	(990-1210)	1815	300	40000	30000	1250	1520

► **34B Dimension**

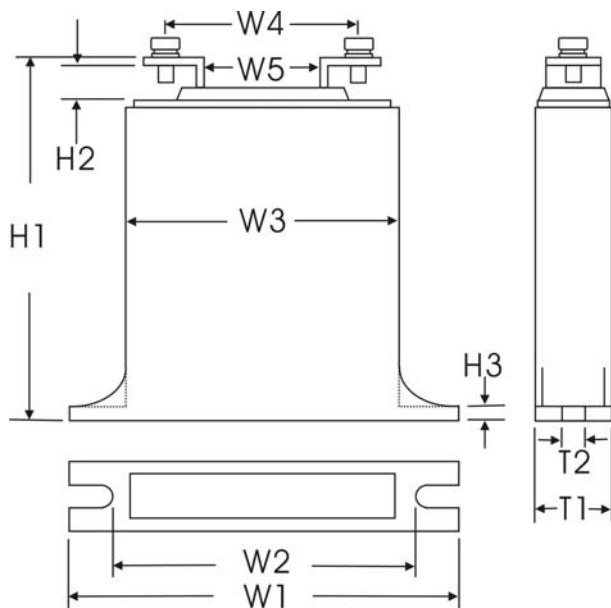

H1	57.0	Max.
H2	5.0	±0.5
H3	3.5	±0.5
W1	60.0	±2.5
W2	47.5	±0.5
W3	42.0	±0.5
W4	24.0	±1.5
W5	14.0	±1.5
T1	14.0	±0.5
T2	4.3	±0.5

Unit: mm

► **Block Type - 60B Specification**

ZOV60B Part No.	Max. Allowable Voltage		Varistor Voltage		Max. Clamping Voltage		Max. Peak Current @ 8/20µs		Max. Energy @ 10/1000µs	Typical Capacitance
	Acrms (V)	DC (V)	V @ 1Ma (V)		VC (V)	IP (A)	1 time (A)	2 times (A)	@10/1000µs (J)	@ 1 KHz (pf)
201K	130	170	200	(185-225)	340	500	70000	50000	550	15000
241K	150	200	240	(216-264)	395	500	70000	50000	650	12500
271K	175	225	270	(243-297)	455	500	70000	50000	700	11000
331K	210	275	330	(297-363)	550	500	70000	50000	825	9000
361K	230	300	360	(324-396)	595	500	70000	50000	850	8500
391K	250	320	390	(351-429)	650	500	70000	50000	885	7500
431K	275	350	430	(387-473)	710	500	70000	50000	990	7000
471K	300	385	470	(423-517)	775	500	70000	50000	1080	6500
511K	320	415	510	(459-561)	845	500	70000	50000	1150	6000
621K	385	505	620	(558-682)	1025	500	70000	50000	1300	5000
681K	420	560	680	(612-748)	1120	500	70000	50000	1350	4500
751K	460	615	750	(675-825)	1240	500	70000	50000	1400	4000
781K	485	640	780	(702-858)	1290	500	70000	50000	1450	3900
821K	510	670	820	(738-902)	1355	500	70000	50000	1600	3700
911K	550	745	910	(819-1001)	1500	500	70000	50000	1700	3300
951K	575	765	950	(855-1045)	1570	500	70000	50000	1800	3200
102K	625	825	1000	(900-1100)	1650	500	70000	50000	1890	3000
112K	680	895	1100	(990-1210)	1815	500	70000	50000	2050	2700

► **60B Dimension**

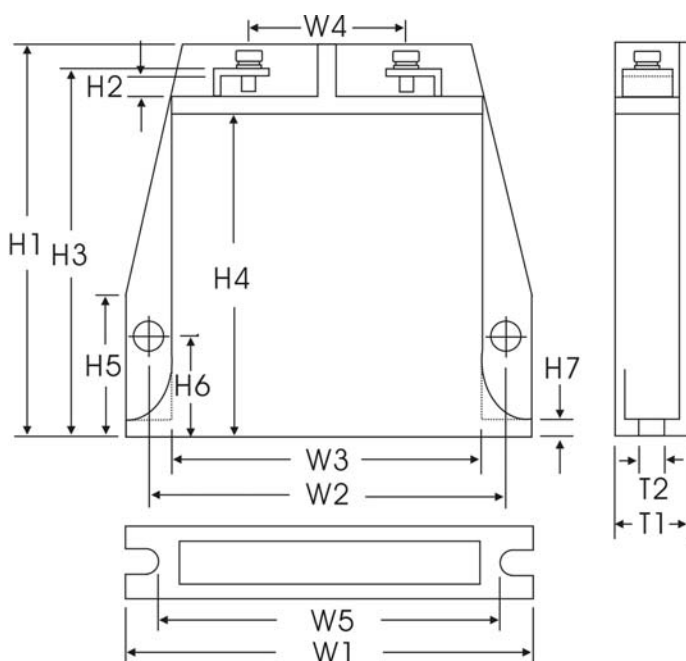

H1	100.0	Max.
H2	5.0	±0.5
H3	92.0	Max.
H4	83.0	Max.
H5	45.0	Max.
H6	30.0	Max.
H6	5.0	Max.
W1	24.0	Max.
W2	7.0	Max.
W3	100.0	Max.
W4	86.0	Max.
W5	71.0	Max.
T1	40.0	Max.
T2	80.0	Max.

Unit: mm

► **Terminology and General Characteristics Definition**

Electrical								
Characteristics	Description							
Standard Test Condition	Environmental conditions under which every measuring is done without doubt on the measurement results unless specially specified. Temperature relative humidity is 5°C to 35°C, 45% to 85% RH.							
Maximum Allowable Voltage	The maximum sinusoidal RMS voltage or maximum DC voltage that can be applied continuously in the specified environmental temperature range.							
Varistor Voltage	The voltage between two terminals with the specified measuring current CmA DC applied is called Vc or VcmA, the measurement shall be made as fast as possible to avoid heat affection.							
Clamping Voltage	The maximum voltage between two terminals with the specified standard impulse current(8/20 μS) illustrated below applied.							
Maximum Peak Current	1 time	The maximum current within the varistor voltage change of ±10% with the standard impulse current(8/20 μS) applied one time.						
	2 times	The maximum current within the varistor± voltage change of ±10% with the standard impulse current(8/20 μS) applied two times with an interval of 5 minutes.						
Maximum Energy	The maximum energy within the varistor voltage change of ±10% when one impulse of 2 ms or 10/1000 μS is applied.							
Rated Power	The power that can be applied in the specified ambient temperature.							
Capacitance	Capacitance shall be measured at 1 kHz±10%, 1Vrms max.(1 MHz below 100pF) 0v bias and 20±2°C.							
Dissipation Factor	Dissipation factor shall be measured at 1kHz±10%, 1Vrms max.(1 MHz±10% below 100pF). 0V bias and 20±2°C.							
Temperature Coefficient of Varistor Voltage	$(V_c \text{ at } 85^\circ\text{C} - V_c \text{ at } 25^\circ\text{C}) / V_c \text{ at } 25^\circ\text{C} * 1/60 * 100(\% / ^\circ\text{C})$							
Withstanding Voltage(Body Insulation)	The specified voltage shall be applied both terminals of the specimen connected together and metal foil closely wrapped around its body for 1 minute. Electrical breakdown shall be examined.							
	<table border="1" style="width: 100%; text-align: center;"> <thead> <tr> <th>Classification (Nominal Varistor Voltage)</th> <th>Test Voltage (AC)</th> </tr> </thead> <tbody> <tr> <td>V0.1mA. V1mA ≤ 330V</td> <td>1000Vrms</td> </tr> <tr> <td>V0.1mA. V1mA &gt; 330V</td> <td>1500Vrms</td> </tr> </tbody> </table>		Classification (Nominal Varistor Voltage)	Test Voltage (AC)	V0.1mA. V1mA ≤ 330V	1000Vrms	V0.1mA. V1mA > 330V	1500Vrms
	Classification (Nominal Varistor Voltage)	Test Voltage (AC)						
	V0.1mA. V1mA ≤ 330V	1000Vrms						
V0.1mA. V1mA > 330V	1500Vrms							
DC Leakage Current	Maximum current with rated DC voltage applied. (Tested by 80% of breakdown voltage).							
Current / Energy Derating	Derating of maximum values when operating above 85°C.							

► Terminology and General Characteristics Definition

Electrical													
Characteristics	Description												
Impulse Life (I)	The change of Vc shall be measured after the impulse listed below is applied 10000 times continuously with the interval of ten seconds at room temperature.	$\Delta V_{cmA} / V_{cmA} \leq \pm 10\%$											
	05D	180K ~ 680K 820K ~ 561K	8A (8/20 $\mu$ s) 40A (8/20 $\mu$ s)										
	07D	180K ~ 680K 820K ~ 681K	25A (8/20 $\mu$ s) 100A (8/20 $\mu$ s)										
	10D	180K ~ 680K 820K ~ 112K	50A (8/20 $\mu$ s) 150A (8/20 $\mu$ s)										
	14D	180K ~ 680K 820K ~ 112K 182K	90A (8/20 $\mu$ s) 300A (8/20 $\mu$ s) 150A (8/20 $\mu$ s)										
	20D	180K ~ 680K 820K ~ 122K 182K	130A (8/20 $\mu$ s) 250A (8/20 $\mu$ s) 200A (8/20 $\mu$ s)										
	Impulse Life (I)	The change of Vc shall be measured after the impulse listed below is applied 100000 times continuously with the interval of ten seconds at room temperature.	$\Delta V_{cmA} / V_{cmA} \leq \pm 10\%$										
		05D	180K ~ 680K 820K ~ 561K	5A (8/20 $\mu$ s) 25A (8/20 $\mu$ s)									
		07D	180K ~ 680K 820K ~ 681K	15A (8/20 $\mu$ s) 60A (8/20 $\mu$ s)									
		10D	180K ~ 680K 820K ~ 112K	35A (8/20 $\mu$ s) 85A (8/20 $\mu$ s)									
		14D	180K ~ 680K 820K ~ 112K 182K	50A (8/20 $\mu$ s) 110A (8/20 $\mu$ s) 80A (8/20 $\mu$ s)									
		20D	180K ~ 680K 820K ~ 122K 182K	65A (8/20 $\mu$ s) 120A (8/20 $\mu$ s) 90A (8/20 $\mu$ s)									
		Impulse Response Time	Time lag between application of surge and varistor's "turn-on" conduction action .	< 25 nanoseconds									
Non Linear Exponent( $\alpha$ )		The varistor voltage-current characteristic is defined by the equation $I=KV^\alpha$ where K is a constant dependent on geometry and $\alpha$ is the non linear exponent. We usually take two points (V <sub>1</sub> , I <sub>1</sub> ), (V <sub>2</sub> , I <sub>2</sub> ) to estimate the value of $\alpha$ .  $\alpha = (\text{Log } I_1/I_2) / (\text{Log } V_1/V_2)$ , in which I <sub>1</sub> and I <sub>2</sub> are the current value, corresponding to the voltage value V <sub>1</sub> and V <sub>2</sub> .	05D ~ 25D										
			<table border="1"> <thead> <tr> <th>Voltage</th> <th><math>\alpha</math> min.</th> </tr> </thead> <tbody> <tr> <td>180 ~ 330K</td> <td>18</td> </tr> <tr> <td>390 ~ 680K</td> <td>20</td> </tr> <tr> <td>820 ~ 151K</td> <td>30</td> </tr> <tr> <td>181 ~ 112K</td> <td>40</td> </tr> </tbody> </table>	Voltage	$\alpha$ min.	180 ~ 330K	18	390 ~ 680K	20	820 ~ 151K	30	181 ~ 112K	40
			Voltage	$\alpha$ min.									
			180 ~ 330K	18									
			390 ~ 680K	20									
820 ~ 151K		30											
181 ~ 112K	40												

► **Terminology and General Characteristics Definition**

<b>Mechanical</b>										
Characteristics	Description									
Robustness of Terminations (Tensile)	<p>After gradually applying the force specified below and keeping the unit fixed for ten seconds. The terminal shall be visually examined for any damage.</p> <table border="1" style="margin-left: auto; margin-right: auto;"> <thead> <tr> <th style="text-align: center;">Terminal Diameter</th> <th style="text-align: center;">Force</th> </tr> </thead> <tbody> <tr> <td style="text-align: center;"><math>\varphi</math> 0.6mm</td> <td style="text-align: center;">9.8N (1.0Kgf)</td> </tr> <tr> <td style="text-align: center;"><math>\varphi</math> 0.8mm</td> <td style="text-align: center;">9.8N (1.0Kgf)</td> </tr> <tr> <td style="text-align: center;"><math>\varphi</math> 1.0mm</td> <td style="text-align: center;">19.6N (2.0Kgf)</td> </tr> </tbody> </table>	Terminal Diameter	Force	$\varphi$ 0.6mm	9.8N (1.0Kgf)	$\varphi$ 0.8mm	9.8N (1.0Kgf)	$\varphi$ 1.0mm	19.6N (2.0Kgf)	No outstanding damages.
Terminal Diameter	Force									
$\varphi$ 0.6mm	9.8N (1.0Kgf)									
$\varphi$ 0.8mm	9.8N (1.0Kgf)									
$\varphi$ 1.0mm	19.6N (2.0Kgf)									
Robustness of Terminations (Bending)	<p>The unit shall be secured with its terminal kept vertical and the force specified below be applied in the axial direction.</p> <p>The terminal shall gradually be bent by 90° in the opposite direction, and again back to the original position.</p> <p>The damage of the terminal shall be visually examined.</p> <table border="1" style="margin-left: auto; margin-right: auto;"> <thead> <tr> <th style="text-align: center;">Terminal Diameter</th> <th style="text-align: center;">Force</th> </tr> </thead> <tbody> <tr> <td style="text-align: center;"><math>\varphi</math> 0.6mm</td> <td style="text-align: center;">4.9N (0.5Kgf)</td> </tr> <tr> <td style="text-align: center;"><math>\varphi</math> 0.8mm</td> <td style="text-align: center;">4.9N (0.5Kgf)</td> </tr> <tr> <td style="text-align: center;"><math>\varphi</math> 1.0mm</td> <td style="text-align: center;">9.8N (1.0Kgf)</td> </tr> </tbody> </table>	Terminal Diameter	Force	$\varphi$ 0.6mm	4.9N (0.5Kgf)	$\varphi$ 0.8mm	4.9N (0.5Kgf)	$\varphi$ 1.0mm	9.8N (1.0Kgf)	No outstanding damages.
Terminal Diameter	Force									
$\varphi$ 0.6mm	4.9N (0.5Kgf)									
$\varphi$ 0.8mm	4.9N (0.5Kgf)									
$\varphi$ 1.0mm	9.8N (1.0Kgf)									
Vibration	<p>After repeatedly applying a single harmonic vibration (amplitude: 0.75mm) double amplitude – 1.5mm with 1 minute vibration frequency cycles (10 Hz to 55 Hz to 10 Hz) to each of three perpendicular directions for 2 hours.</p> <p>Thereafter the unit shall be visually examined.</p>	N/A.								
Solderability	<p>After dipping the terminals to a depth of approximately 3 mm from the body in a soldering bath of 230±10°C for 2±1.0 seconds, the terminal shall be visually examined.</p>	Approximately 95% of the terminals shall be covered with solder uniformly.								
Resistance to Soldering Heat	<p>After each lead shall be dipped into a solder bath having a temperature 260±5°C, to a point 2.0 to 2.5mm from the body of the unit, using shielding board (t=1.5mm) and held there for specified time (5 series - 5±1.0 second and others - 10±1.0 second). Then be stored at room temperature and humidity for 1 to 2 hours. The change of VC and mechanical damages are examined.</p>	$\Delta V_{cmA} / V_{cmA} \leq \pm 5\%$ , no outstanding damages.								

► **Terminology and General Characteristics Definition**

Environmental																	
Characteristics	Description	Specifications															
High Temperature Storage / Dry Heat	The specimen shall be subjected to $125\pm 2^{\circ}\text{C}$ for 1000 hours in a thermostatic bath without load and then stored at room temperature and humidity for 1 to 2 hours. Thereafter the change of Vc shall be measured.	$\Delta V_{cmA} / V_{cmA} \leq \pm 5\%$															
Damp Heat / Humidity (Steady State)	The specimen shall be subjected to $40\pm 2^{\circ}\text{C}$ at 90 to 95% RH for 1000 hours without load and then stored at room temperature and humidity for 1 to 2 hours. Thereafter the change of Vc shall be measured.	$\Delta V_{cmA} / V_{cmA} \leq \pm 5\%$															
Temperature Cycle	The temperature cycle shown below shall be repeated five times and then stored at room temperature and humidity for 1 to 2 hours. Thereafter the change of Vc and mechanical damages shall be examined.	$\Delta V_{cmA} / V_{cmA} \leq \pm 5\%$															
	<table border="1"> <thead> <tr> <th>Step</th> <th>Temperature</th> <th>Period</th> </tr> </thead> <tbody> <tr> <td>1</td> <td><math>-40\pm 3^{\circ}\text{C}</math></td> <td><math>30\pm 3.0</math> min.</td> </tr> <tr> <td>2</td> <td>Room temperature</td> <td><math>15\pm 3.0</math> min.</td> </tr> <tr> <td>3</td> <td><math>125\pm 2^{\circ}\text{C}</math></td> <td><math>30\pm 3.0</math> min.</td> </tr> <tr> <td>4</td> <td>Room temperature</td> <td><math>15\pm 3.0</math> min.</td> </tr> </tbody> </table>		Step	Temperature	Period	1	$-40\pm 3^{\circ}\text{C}$	$30\pm 3.0$ min.	2	Room temperature	$15\pm 3.0$ min.	3	$125\pm 2^{\circ}\text{C}$	$30\pm 3.0$ min.	4	Room temperature	$15\pm 3.0$ min.
	Step		Temperature	Period													
	1		$-40\pm 3^{\circ}\text{C}$	$30\pm 3.0$ min.													
	2		Room temperature	$15\pm 3.0$ min.													
3	$125\pm 2^{\circ}\text{C}$	$30\pm 3.0$ min.															
4	Room temperature	$15\pm 3.0$ min.															
High Temperature Load / Dry Heat Load	After being continuously applied the maximum allowable voltage at $85\pm 2^{\circ}\text{C}$ for 1000 hours, the specimen shall be stored at room temperature and humidity for 1 to 2 hours. Thereafter the change of Vc shall be measured.	$\Delta V_{cmA} / V_{cmA} \leq \pm 10\%$															
Damp Heat Load / Humidity Load	The specimen shall be subjected to $40\pm 2^{\circ}\text{C}$ at 90 to 95% RH and maximum allowable voltage for 1000 hours and then stored at room temperature and humidity for 1 to 2 hours. Thereafter the change of Vc shall be measured.	$\Delta V_{cmA} / V_{cmA} \leq \pm 10\%$															
Low Temperature Storage / Cold	The specimen shall be subjected to $-40\pm 2^{\circ}\text{C}$ without load for 1000 hours and then stored at room temperature for 1 to 2 hours. Thereafter the change of Vc shall be measured.	$\Delta V_{cmA} / V_{cmA} \leq \pm 5\%$															

► **How to Select A Varistor**

For most applications, the selection has six processes.

Step	Description
1	<p>Normal operating conditions of the varistor.</p> <p>Varistor voltage – the voltage under 1mA constant current test. Select the varistor with higher voltage.</p> <p>A.C. / D.C. = max. rms. or DC voltage. Select the max. voltage equal or higher than the peak working voltage.</p>
2	<p>The transient energy absorbed by the varistor.</p> <p>To determine the energy absorbed in the varistor, the following equation can be applied.</p> <p><math>E = K * IP * Vc * T</math>, where K is a constant.</p> <p>K value is 1.0 for a rectangular waveform, 1.4 for a 10/1000 <math>\mu</math>s and 8/20 <math>\mu</math>s waveform. IP is the peak current applied. Vc is the clamping voltage which is current applied. T is the pulse width.</p> <div style="display: flex; justify-content: space-around;"> <div data-bbox="204 705 730 1097"> <p>8/20 <math>\mu</math>s Test Wave</p> </div> <div data-bbox="821 689 1236 1108"> </div> </div> <p>One thing must be noted that the rated energy and the energy absorbed in a varistor may not be identical. Poorer varistor will absorb higher energy and the better varistor which performs a lower clamping voltage will absorb less energy, yet actually provides a better over-voltage protection.</p>
3	<p>Max. transient voltage that the equipment to be protected can withstand. Select lower clamping voltage than the equipment can endure. It's easy to find varistor clamping voltage from V-I curve when the transient current is known.</p>
4	<p>Max. the peak transient current that the varistor can withstand.</p>
5	<p>Number of transient current expected surge during life evaluate the total transient numbers in the circuit and the max. peak current. Then select the suitable model that can endure.</p>
6	<p>Determine power dissipation requirements. If the transients generate heat in a varistor too quick, it can't be transferred during the pulse interval and will cause the varistor failure. Under this condition, the power dissipation so developed must be within the specifications shown on the ratings table. Also be noted that varistor can only dissipate a repetitive applications that involve substantial amounts average energy dissipation. Furthermore, the operating values will be decreased at high temperature as shown in the following figure.</p> <div style="text-align: center;"> </div>

## ► Applications

Recommend Applications	5mm	7mm	10mm	14mm	20mm
■ Protection for various kinds of semiconductors	180K	180K	180K	180K	180K
■ Protection for automobile equipments	220K	220K	220K	220K	220K
■ Absorption for switching surge from various kinds of relays and electro-magnetic valves(DC below 48V)	270K	270K	270K	270K	270K
■ Protection for electronic equipment from electrostatic discharge	330K	330K	330K	330K	330K
■ Protection for cellular phone	390K	390K	390K	390K	390K
	470K	470K	470K	470K	470K
	560K	560K	560K	560K	560K
	680K	680K	680K	680K	680K
■ Telephone: communication line(DC 48V)	820K	820K	820K	820K	820K
	101K	101K	101K	101K	101K
	121K	121K	121K	121K	121K
	151K	151K	151K	151K	151K
■ AC 100V line-line applications(Japan)	181K	181K	181K	181K	181K
	201K	201K	201K	201K	201K
	221K	221K	221K	221K	221K
■ AC 100V to 120V line-line applications(Japan, U.S., Canada...etc.)	241K	241K	241K	241K	241K
	271K	271K	271K	271K	271K
	301K	301K	301K	301K	301K
■ Telephone line application(250V Insulation resistance test applicable)	331K	331K	331K	331K	331K
	361K	361K	361K	361K	361K
	391K	391K	391K	391K	391K
■ AC 200V/220V line-line applications	431K	431K	431K	431K	431K
■ AC 100V to 220V line-ground applications	471K	471K	471K	471K	471K
■ AC 240V line-line applications(U.K., Australia, Middle east countries...etc.)	561K	561K	561K	561K	561K
		621K	621K	621K	621K
		681K	681K	681K	681K
■ AC 380V line-line and line-ground applications			751K	751K	751K
			781K	781K	781K
			821K	821K	821K
■ AC 415V line-line and line-ground applications			911K	911K	911K
■ AC 480V line-line and line-ground applications			102K	102K	102K
			112K	112K	112K
■ Line-ground applications(For AC 1200V withstanding test)				182K	182K

# L. S. TECH Co., Ltd.

GaoLing Ind. Zone, QiuChang Town, HuiYang Dist.,  
HuiZhou City, GuangDong, CHINA 516221

Tel. +86-752-3358870

Fax +86-752-3358770 e-Fax +852-30072967

LSZOV@yahoo.com.tw



**ZOV**

---

---