

TL431, TL431A, TL431B TL432, TL432A, TL432B ADJUSTABLE PRECISION SHUNT REGULATORS

SLVS543I – AUGUST 2004 – REVISED MAY 2005

- Operation From -40°C to 125°C
- Reference Voltage Tolerance at 25°C
 - 0.5% . . . B Grade
 - 1% . . . A Grade
 - 2% . . . Standard Grade
- Typical Temperature Drift (TL431B)
 - 6 mV (C Temp)
 - 14 mV (I Temp, Q Temp)
- Low Output Noise
- 0.2- Ω Typical Output Impedance
- Sink-Current Capability . . . 1 mA to 100 mA
- Adjustable Output Voltage . . . V_{ref} to 36 V

TL431, TL431A, TL431B . . . D (SOIC) PACKAGE
(TOP VIEW)

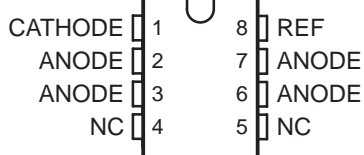

NC – No internal connection

TL431, TL431A, TL431B . . . P (PDIP), PS (SOP),
OR PW (TSSOP) PACKAGE
(TOP VIEW)

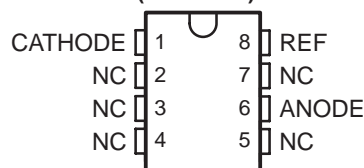

NC – No internal connection

TL431, TL431A, TL431B . . . PK (SOT-89) PACKAGE
(TOP VIEW)

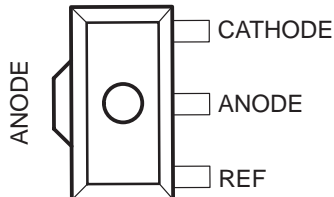

TL432, TL432A, TL432B . . . PK (SOT-89) PACKAGE
(TOP VIEW)

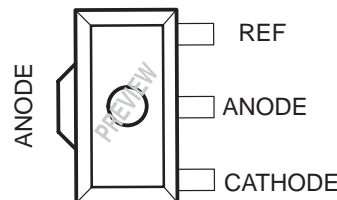

TL431, TL431A, TL431B . . . DBV (SOT-23-5) PACKAGE
(TOP VIEW)

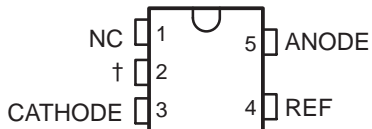

NC – No internal connection
† Pin 2 must be connected to ANODE or left open.

TL432, TL432A, TL432B . . . DBV (SOT-23-5) PACKAGE
(TOP VIEW)

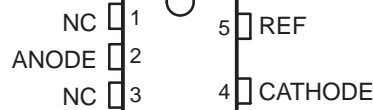

NC – No internal connection

TL431, TL431A, TL431B . . . DBZ (SOT-23-3) PACKAGE
(TOP VIEW)

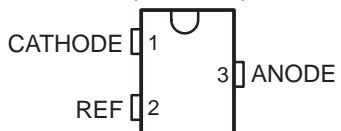

TL432, TL432A, TL432B . . . DBZ (SOT-23-3) PACKAGE
(TOP VIEW)

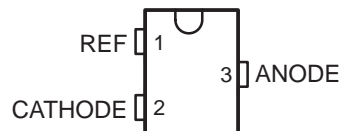

Please be aware that an important notice concerning availability, standard warranty, and use in critical applications of Texas Instruments semiconductor products and disclaimers thereto appears at the end of this data sheet.

PowerFLEX is a trademark of Texas Instruments.

PRODUCTION DATA information is current as of publication date. Products conform to specifications per the terms of Texas Instruments standard warranty. Production processing does not necessarily include testing of all parameters.



POST OFFICE BOX 655303 • DALLAS, TEXAS 75265

Copyright © 2005, Texas Instruments Incorporated

TL431, TL431A, TL431B TL432, TL432A, TL432B ADJUSTABLE PRECISION SHUNT REGULATORS

SLVS543I – AUGUST 2004 – REVISED MAY 2005

TL431, TL431A, TL431B . . . LP (TO-92/TO-226) PACKAGE
(TOP VIEW)

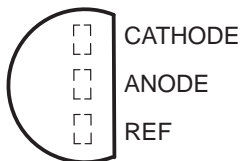

TL431A, TL431B . . . DCK (SC-70) PACKAGE
(TOP VIEW)

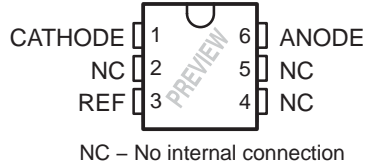

NC – No internal connection

TL431 . . . KTP (PowerFLEX™/TO-252) PACKAGE
(TOP VIEW)

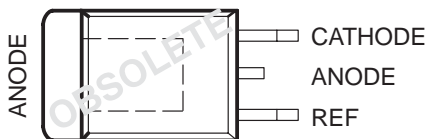

description/ordering information

The TL431 and TL432 are three-terminal adjustable shunt regulators, with specified thermal stability over applicable automotive, commercial, and military temperature ranges. The output voltage can be set to any value between V_{ref} (approximately 2.5 V) and 36 V, with two external resistors (see Figure 17). These devices have a typical output impedance of 0.2 Ω . Active output circuitry provides a very sharp turn-on characteristic, making these devices excellent replacements for Zener diodes in many applications, such as onboard regulation, adjustable power supplies, and switching power supplies. The TL432 has exactly the same functionality and electrical specifications as the TL431, but has different pinouts for the DBV, DBZ, and PK packages.

Both the TL431 and TL432 devices are offered in three grades, with initial tolerances (at 25°C) of 0.5%, 1%, and 2%, for the B, A, and standard grade, respectively. In addition, low output drift vs temperature ensures good stability over the entire temperature range.

The TL43xxC devices are characterized for operation from 0°C to 70°C, the TL43xxI devices are characterized for operation from –40°C to 85°C, and the TL43xxQ devices are characterized for operation from –40°C to 125°C.

TL431, TL431A, TL431B
TL432, TL432A, TL432B
ADJUSTABLE PRECISION SHUNT REGULATORS

SLVS543I – AUGUST 2004 – REVISED MAY 2005

V_{ref} TOLERANCE (25°C) = 2%
TL431, TL432 ORDERING INFORMATION

T _A	PACKAGE†		ORDERABLE PART NUMBER	TOP-SIDE MARKING‡
0°C to 70°C	PDIP (P)	Tube of 50	TL431CP	TL431CP
	SOIC (D)	Tube of 75	TL431CD	TL431C
		Reel of 2500	TL431CDR	
	SOP (PS)	Reel of 2000	TL431CPSR	T431
	SOT-23-5 (DBV)	Reel of 3000	TL431CDBVR	T3C_
		Reel of 250	TL431CDBVT	
		Reel of 3000	TL432CDBVR	T4C_
		Reel of 250	TL432CDBVT	
	SOT-23-3 (DBZ)	Reel of 3000	TL431CDBZR	T3C_
		Reel of 250	TL431CDBZT	
		Reel of 3000	TL432CDBZR	T4C_
		Reel of 250	TL432CDBZT	
	SOT-89 (PK)	Reel of 1000	TL431CPK	43
			TL432CPK	2A
	TO-226/TO-92 (LP)	Bulk of 1000, straight lead	TL431CLP	TL431C
		Ammo of 2000, formed lead	TL431CLPM	
Reel of 2000, formed lead		TL431CLPR		
TSSOP (PW)	Tube of 150	TL431CPW	T431	
	Reel of 2000	TL431CPWR		
-40°C to 85°C	PDIP (P)	Tube of 50	TL431IP	TL431IP
	SOIC (D)	Tube of 75	TL431ID	TL431I
		Reel of 2500	TL431IDR	
	SOT-23-5 (DBV)	Reel of 3000	TL431IDBVR	T3I_
		Reel of 250	TL431IDBVT	
		Reel of 3000	TL432IDBVR	T4I_
		Reel of 250	TL432IDBVT	
	SOT-23-3 (DBZ)	Reel of 3000	TL431IDBZR	T3I_
		Reel of 250	TL431IDBZT	
		Reel of 3000	TL432IDBZR	T4I_
		Reel of 250	TL432IDBZT	
	SOT-89 (PK)	Reel of 1000	TL431IPK	3I
			TL432IPK	2B
	TO-226/TO-92 (LP)	Bulk of 1000, straight lead	TL431ILP	TL431I
		Ammo of 2000, formed lead	TL431ILPM	
		Reel of 2000, formed lead	TL431ILPR	

† Package drawings, standard packing quantities, thermal data, symbolization, and PCB design guidelines are available at www.ti.com/sc/package.

‡ DBV/DBZ: The actual top-side marking has one additional character that designates the assembly/test site.



TL431, TL431A, TL431B
TL432, TL432A, TL432B
ADJUSTABLE PRECISION SHUNT REGULATORS

SLVS543I – AUGUST 2004 – REVISED MAY 2005

V_{ref} TOLERANCE (25°C) = 2%
TL431, TL432 ORDERING INFORMATION (CONTINUED)

T_A	PACKAGE†		ORDERABLE PART NUMBER	TOP-SIDE MARKING‡
-40°C to 125°C	SOT-23-5 (DBV)	Reel of 3000	TL431QDBVR	T3Q_
		Reel of 250	TL431QDBVT	
		Reel of 3000	TL432QDBVR	T4Q_
		Reel of 250	TL432QDBVT	
	SOT-23-3 (DBZ)	Reel of 3000	TL431QDBZR	T3Q_
		Reel of 250	TL431QDBZT	
		Reel of 3000	TL432QDBZR	T4Q_
		Reel of 250	TL432QDBZT	
	SOT-89 (PK)	Reel of 1000	TL431QPK	3Q
			TL432QPK	2C
	SC-70 (DCK)	Reel of 1000	TL431QDCKR	T6_
		Reel of 250	TL431QDCKT	

† Package drawings, standard packing quantities, thermal data, symbolization, and PCB design guidelines are available at www.ti.com/sc/package.

‡ DBV/DBZ/DCK: The actual top-side marking has one additional character that designates the assembly/test site.

TL431, TL431A, TL431B
TL432, TL432A, TL432B
ADJUSTABLE PRECISION SHUNT REGULATORS

SLVS543I – AUGUST 2004 – REVISED MAY 2005

V_{ref} TOLERANCE (25°C) = 1%
TL431A, TL432A ORDERING INFORMATION

T _A	PACKAGE†		ORDERABLE PART NUMBER	TOP-SIDE MARKING‡
0°C to 70°C	PDIP (P)	Tube of 50	TL431ACP	TL431ACP
	SC-70 (DCK)	Reel of 3000	TL431ACDCKR	T4_
		Reel of 250	TL431ACDCKT	
	SOIC (D)	Tube of 75	TL431ACD	431AC
		Reel of 2500	TL431ACDR	
	SOP (PS)	Reel of 2000	TL431ACPSR	T431A
	SOT-23-5 (DBV)	Reel of 3000	TL431ACDBVR	TAC_
		Reel of 250	TL431ACDBVT	
		Reel of 3000	TL432ACDBVR	T4B_
		Reel of 250	TL432ACDBVT	
	SOT-23-3 (DBZ)	Reel of 3000	TL431ACDBZR	TAC_
		Reel of 250	TL431ACDBZT	
		Reel of 3000	TL432ACDBZR	T4B_
		Reel of 250	TL432ACDBZT	
	SOT-89 (PK)	Reel of 1000	TL431ACPK	4A
			TL432ACPK	2D
	TO-226/TO-92 (LP)	Bulk of 1000, straight lead	TL431ACLP	TL431AC
		Ammo of 2000, formed lead	TL431ACLPM	
		Reel of 2000, formed lead	TL431ACLPR	
		Reel of 2000, formed lead	TL431ACLPRE3	
TSSOP (PW)	Tube of 150	TL431ACPW	T431A	
	Reel of 2000	TL431ACPWR		

† Package drawings, standard packing quantities, thermal data, symbolization, and PCB design guidelines are available at www.ti.com/sc/package.

‡ DBV/DBZ/DCK: The actual top-side marking has one additional character that designates the assembly/test site.



**TL431, TL431A, TL431B
TL432, TL432A, TL432B
ADJUSTABLE PRECISION SHUNT REGULATORS**

SLVS5431 – AUGUST 2004 – REVISED MAY 2005

**V_{ref} TOLERANCE (25°C) = 1%
TL431A, TL432A ORDERING INFORMATION (CONTINUED)**

T_A	PACKAGE†		ORDERABLE PART NUMBER	TOP-SIDE MARKING‡
-40°C to 85°C	PDIP (P)	Tube of 50	TL431AIP	TL431AIP
	SC-70 (DCK)	Reel of 3000	TL431AIDCKR	T5_
		Reel of 250	TL431AIDCKT	
	SOIC (D)	Tube of 75	TL431AID	431AI
		Reel of 2500	TL431AIDR	
	SOT-23-5 (DBV)	Reel of 3000	TL431AIDBVR	TAI_
		Reel of 250	TL431AIDBVT	
		Reel of 3000	TL432AIDBVR	T4A_
		Reel of 250	TL432AIDBVT	
	SOT-23-3 (DBZ)	Reel of 3000	TL431AIDBZR	TAI_
		Reel of 250	TL431AIDBZT	
		Reel of 3000	TL432AIDBZR	T4A_
		Reel of 250	TL432AIDBZT	
	SOT-89 (PK)	Reel of 1000	TL431AIPK	4B
			TL432AIPK	2E
	TO-226/TO-92 (LP)	Bulk of 1000, straight lead	TL431AILP	TL431AI
Ammo of 2000, formed lead		TL431AILPM		
Reel of 2000, formed lead		TL431AILPR		
-40°C to 125°C	SOT-23-5 (DBV)	Reel of 3000	TL431AQDBVR	TAQ_
		Reel of 250	TL431AQDBVT	
		Reel of 3000	TL432AQDBVR	T4D_
		Reel of 250	TL432AQDBVT	
	SOT-23-3 (DBZ)	Reel of 3000	TL431AQDBZR	TAQ_
		Reel of 250	TL431AQDBZT	
		Reel of 3000	TL432AQDBZR	T4D_
		Reel of 250	TL432AQDBZT	
	SOT-89 (PK)	Reel of 1000	TL431AQPK	4D
			TL432AQPK	2F
SC-70 (PK)	Reel of 1000	TL431AQDCKR	T7_	
	Reel of 250	TL431AQDCKT		

† Package drawings, standard packing quantities, thermal data, symbolization, and PCB design guidelines are available at www.ti.com/sc/package.

‡ DBV/DBZ/DCK: The actual top-side marking has one additional character that designates the assembly/test site.



TL431, TL431A, TL431B
TL432, TL432A, TL432B
ADJUSTABLE PRECISION SHUNT REGULATORS

SLVS543I – AUGUST 2004 – REVISED MAY 2005

V_{ref} TOLERANCE (25°C) = 0.5%
TL431B, TL432B ORDERING INFORMATION

T _A	PACKAGE†		ORDERABLE PART NUMBER	TOP-SIDE MARKING‡
0°C to 70°C	PDIP (P)	Tube of 50	TL431BCP	TL431BCP
	SC-70 (DCK)	Reel of 3000	TL431BCDCKR	T2_
		Reel of 250	TL431BCDCKT	
	SOIC (D)	Tube of 75	TL431BCD	T431B
		Reel of 2500	TL431BCDR	
	SOP (PS)	Reel of 2000	TL431BCPSR	TL431B
	SOT-23-5 (DBV)	Reel of 3000	TL431BCDBVR	T3G_
		Reel of 250	TL431BCDBVT	
		Reel of 3000	TL432BCDBVR	TBC_
		Reel of 250	TL432BCDBVT	
	SOT-23-3 (DBZ)	Reel of 3000	TL431BCDBZR	T3G_
		Reel of 250	TL431BCDBZT	
		Reel of 3000	TL432BCDBZR	TBC_
		Reel of 250	TL432BCDBZT	
	SOT-89 (PK)	Reel of 1000	TL431BCPK	4C
			TL432BCPK	2G
	TO-226/TO-92 (LP)	Bulk of 1000, straight lead	TL431BCLP	TL431B
		Ammo of 2000, formed lead	TL431BCLPM	
		Reel of 2000, formed lead	TL431BCLPR	
	TSSOP (PW)	Tube of 150	TL431BCPW	T431B
Reel of 2000		TL431BCPWR		

† Package drawings, standard packing quantities, thermal data, symbolization, and PCB design guidelines are available at www.ti.com/sc/package.

‡ DBV/DBZ/DCK: The actual top-side marking has one additional character that designates the assembly/test site.

TL431, TL431A, TL431B
TL432, TL432A, TL432B
ADJUSTABLE PRECISION SHUNT REGULATORS

SLVS5431 – AUGUST 2004 – REVISED MAY 2005

V_{ref} TOLERANCE (25°C) = 0.5%
TL431B, TL432B ORDERING INFORMATION (CONTINUED)

T_A	PACKAGE†		ORDERABLE PART NUMBER	TOP-SIDE MARKING‡
-40°C to 85°C	PDIP (P)	Tube of 50	TL431BIP	TL431BIP
	SC-70 (DCK)	Reel of 3000	TL431BIDCKR	T3_
		Reel of 250	TL431BIDCKT	
	SOIC (D)	Tube of 75	TL431BID	Z431B
		Reel of 2500	TL431BIDR	
	SOT-23-5 (DBV)	Reel of 3000	TL431BIDBVR	T3F_
		Reel of 250	TL431BIDBVT	
		Reel of 3000	TL432BIDBVR	T4F_
		Reel of 250	TL432BIDBVT	
	SOT-23-3 (DBZ)	Reel of 3000	TL431BIDBZR	T3F_
		Reel of 250	TL431BIDBZT	
		Reel of 3000	TL432BIDBZR	T4F_
		Reel of 250	TL432BIDBZT	
	SOT-89 (PK)	Reel of 1000	TL431BIPK	4I
			TL432BIPK	2H
	TO-226/TO-92 (LP)	Bulk of 1000, straight lead	TL431BILP	Z431B
		Ammo of 2000, formed lead	TL431BILPM	
		Reel of 2000, fomed lead	TL431BILPR	

† Package drawings, standard packing quantities, thermal data, symbolization, and PCB design guidelines are available at www.ti.com/sc/package.

‡ DBV/DBZ/DCK: The actual top-side marking has one additional character that designates the assembly/test site.



TL431, TL431A, TL431B
TL432, TL432A, TL432B
ADJUSTABLE PRECISION SHUNT REGULATORS

SLVS543I – AUGUST 2004 – REVISED MAY 2005

V_{ref} TOLERANCE (25°C) = 0.5%
TL431B, TL432B ORDERING INFORMATION (CONTINUED)

T _A	PACKAGE†		ORDERABLE PART NUMBER	TOP-SIDE MARKING‡	
-40°C to 125°C	SOIC (D)	Tube of 75	TL431BQD	T431BQ	
		Reel of 2500	TL431BQDR		
	SOT-23-5 (DBV)	Reel of 3000	TL431BQDBVR	T3H_	
			Reel of 250		TL431BQDBVT
		Reel of 3000	TL432BQDBVR	T4H_	
			Reel of 250		TL432BQDBVT
			Reel of 250		TL432BQDBVT
	SOT-23-3 (DBZ)	Reel of 3000	TL431BQDBZR	T3H_	
			Reel of 250		TL431BQDBZT
		Reel of 3000	TL432BQDBZR	T4H_	
			Reel of 250		TL432BQDBZT
	SOT-89 (PK)	Reel of 1000	TL431BQPK	3H	
			TL432BQPK	2J	
	TO-226/TO-92 (LP)	Bulk of 1000, straight lead	TL431BQLP	T431BQ	
		Ammo of 2000, formed lead	TL431BQLPM		
		Reel of 2000, formed lead	TL431BQLPR		
SC-70 (DCK)	Reel of 1000	TL431BQDCKR	T8_		
		Reel of 250		TL431BQDCKT	

† Package drawings, standard packing quantities, thermal data, symbolization, and PCB design guidelines are available at www.ti.com/sc/package.

‡ DBV/DBZ/DCK: The actual top-side marking has one additional character that designates the assembly/test site.

TL431, TL431A, TL431B TL432, TL432A, TL432B ADJUSTABLE PRECISION SHUNT REGULATORS

SLVS543I – AUGUST 2004 – REVISED MAY 2005

symbol

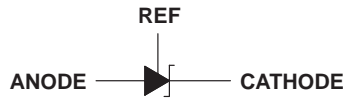

functional block diagram

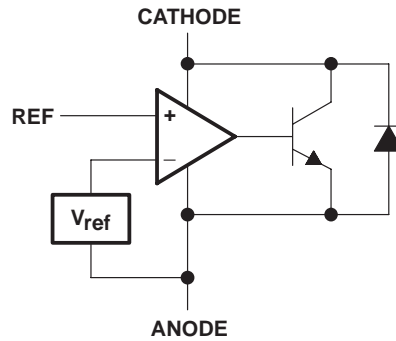

equivalent schematic†

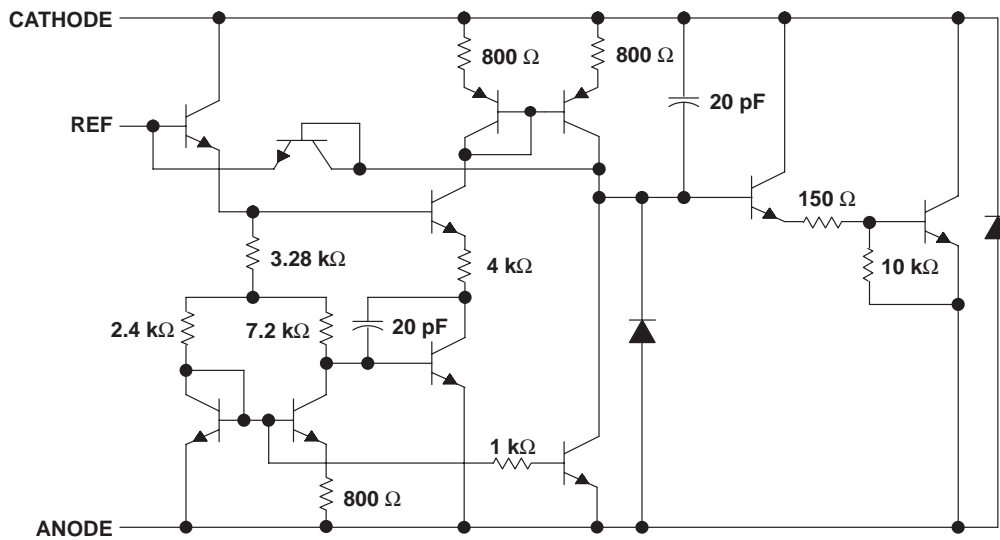

† All component values are nominal.

TL431, TL431A, TL431B
TL432, TL432A, TL432B
ADJUSTABLE PRECISION SHUNT REGULATORS

SLVS543I – AUGUST 2004 – REVISED MAY 2005

absolute maximum ratings over operating free-air temperature range (unless otherwise noted)‡

Cathode voltage, V_{KA} (see Note 1)	37 V
Continuous cathode current range, I_{KA}	–100 mA to 150 mA
Reference input current range	–50 μ A to 10 mA
Operating virtual junction temperature, T_J	150°C
Storage temperature range, T_{Stg}	–65°C to 150°C

‡ Stresses beyond those listed under “absolute maximum ratings” may cause permanent damage to the device. These are stress ratings only, and functional operation of the device at these or any other conditions beyond those indicated under “recommended operating conditions” is not implied. Exposure to absolute-maximum-rated conditions for extended periods may affect device reliability.

NOTE 1: Voltage values are with respect to the ANODE terminal, unless otherwise noted.

package thermal data (see Note 2)

PACKAGE	BOARD	θ_{JC}	θ_{JA}
PDIP (P)	High K, JESD 51-7	57°C/W	85°C/W
SC-70 (DCK)	High K, JESD 51-7	259°C/W	87°C/W
SOIC (D)	High K, JESD 51-7	39°C/W	97°C/W
SOP (PS)	High K, JESD 51-7	46°C/W	95°C/W
SOT-89 (PK)	High K, JESD 51-7	9°C/W	52°C/W
SOT-23-5 (DBV)	High K, JESD 51-7	131°C/W	206°C/W
SOT-23-3 (DBZ)	High K, JESD 51-7	76°C/W	206°C/W
TO-92 (LP)	High K, JESD 51-7	55°C/W	140°C/W
TSSOP (PW)	High K, JESD 51-7	65°C/W	149°C/W

NOTE 2: Maximum power dissipation is a function of $T_J(\max)$, θ_{JA} , and T_A . The maximum allowable power dissipation at any allowable ambient temperature is $P_D = (T_J(\max) - T_A)/\theta_{JA}$. Operating at the absolute maximum T_J of 150°C can affect reliability.

recommended operating conditions

		MIN	MAX	UNIT	
V_{KA}	Cathode voltage	V_{ref}	36	V	
I_{KA}	Cathode current	1	100	mA	
T_A	Operating free-air temperature range	TL43xxC	0	70	°C
		TL43xxI	–40	85	
		TL43xxQ	–40	125	



TL431, TL431A, TL431B TL432, TL432A, TL432B ADJUSTABLE PRECISION SHUNT REGULATORS

SLVS543I – AUGUST 2004 – REVISED MAY 2005

electrical characteristics over recommended operating conditions, $T_A = 25^\circ\text{C}$ (unless otherwise noted)

PARAMETER	TEST CIRCUIT	TEST CONDITIONS	TL431C TL432C			UNIT	
			MIN	TYP	MAX		
V_{ref} Reference voltage	2	$V_{\text{KA}} = V_{\text{ref}}, I_{\text{KA}} = 10 \text{ mA}$	2440	2495	2550	mV	
$V_{\text{I(dev)}}$ Deviation of reference voltage over full temperature range (see Figure 1)	2	$V_{\text{KA}} = V_{\text{ref}}, I_{\text{KA}} = 10 \text{ mA}, T_A = 0^\circ\text{C} \text{ to } 70^\circ\text{C}$	SOT23-3 and TL432 devices		6	16	mV
		All other devices		4	25		
$\frac{\Delta V_{\text{ref}}}{\Delta V_{\text{KA}}}$ Ratio of change in reference voltage to the change in cathode voltage	3	$I_{\text{KA}} = 10 \text{ mA}$	$\Delta V_{\text{KA}} = 10 \text{ V} - V_{\text{ref}}$		-1.4	-2.7	$\frac{\text{mV}}{\text{V}}$
			$\Delta V_{\text{KA}} = 36 \text{ V} - 10 \text{ V}$		-1	-2	
I_{ref} Reference current	3	$I_{\text{KA}} = 10 \text{ mA}, R1 = 10 \text{ k}\Omega, R2 = \infty$			2	4	μA
$I_{\text{I(dev)}}$ Deviation of reference current over full temperature range (see Figure 1)	3	$I_{\text{KA}} = 10 \text{ mA}, R1 = 10 \text{ k}\Omega, R2 = \infty, T_A = 0^\circ\text{C} \text{ to } 70^\circ\text{C}$			0.4	1.2	μA
I_{min} Minimum cathode current for regulation	2	$V_{\text{KA}} = V_{\text{ref}}$			0.4	1	mA
I_{off} Off-state cathode current	4	$V_{\text{KA}} = 36 \text{ V}, V_{\text{ref}} = 0$			0.1	1	μA
$ z_{\text{KA}} $ Dynamic impedance (see Figure 1)	1	$I_{\text{KA}} = 1 \text{ mA} \text{ to } 100 \text{ mA}, V_{\text{KA}} = V_{\text{ref}}, f \leq 1 \text{ kHz}$			0.2	0.5	Ω

The deviation parameters $V_{\text{ref(dev)}}$ and $I_{\text{ref(dev)}}$ are defined as the differences between the maximum and minimum values obtained over the recommended temperature range. The average full-range temperature coefficient of the reference voltage, $\alpha_{V_{\text{ref}}}$, is defined as:

$$|\alpha_{V_{\text{ref}}}| \left(\frac{\text{ppm}}{^\circ\text{C}} \right) = \frac{\left(\frac{V_{\text{I(dev)}}}{V_{\text{ref at } 25^\circ\text{C}}} \right) \times 10^6}{\Delta T_A}$$

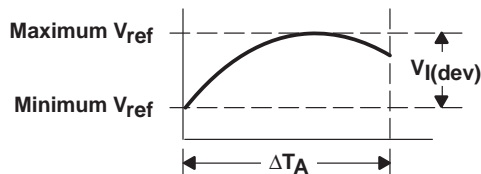

where:

ΔT_A is the recommended operating free-air temperature range of the device.

$\alpha_{V_{\text{ref}}}$ can be positive or negative, depending on whether minimum V_{ref} or maximum V_{ref} , respectively, occurs at the lower temperature.

Example: maximum $V_{\text{ref}} = 2496 \text{ mV}$ at 30°C , minimum $V_{\text{ref}} = 2492 \text{ mV}$ at 0°C , $V_{\text{ref}} = 2495 \text{ mV}$ at 25°C , $\Delta T_A = 70^\circ\text{C}$ for TL431C

$$|\alpha_{V_{\text{ref}}}| = \frac{\left(\frac{4 \text{ mV}}{2495 \text{ mV}} \right) \times 10^6}{70^\circ\text{C}} \approx \frac{23 \text{ ppm}}{^\circ\text{C}}$$

Because minimum V_{ref} occurs at the lower temperature, the coefficient is positive.

Calculating Dynamic Impedance

The dynamic impedance is defined as: $|z_{\text{KA}}| = \frac{\Delta V_{\text{KA}}}{\Delta I_{\text{KA}}}$

When the device is operating with two external resistors (see Figure 3), the total dynamic impedance of the circuit is given by:

$$|z'| = \frac{\Delta V}{\Delta I} \approx |z_{\text{KA}}| \left(1 + \frac{R1}{R2} \right)$$

Figure 1. Calculating Deviation Parameters and Dynamic Impedance

TL431, TL431A, TL431B
TL432, TL432A, TL432B
ADJUSTABLE PRECISION SHUNT REGULATORS

SLVS543I – AUGUST 2004 – REVISED MAY 2005

electrical characteristics over recommended operating conditions, $T_A = 25^\circ\text{C}$ (unless otherwise noted)

PARAMETER	TEST CIRCUIT	TEST CONDITIONS	TL431I TL432I			UNIT	
			MIN	TYP	MAX		
V_{ref} Reference voltage	2	$V_{\text{KA}} = V_{\text{ref}}$, $I_{\text{KA}} = 10\text{ mA}$	2440	2495	2550	mV	
$V_{\text{I(dev)}}$ Deviation of reference voltage over full temperature range (see Figure 1)	2	$V_{\text{KA}} = V_{\text{ref}}$, $I_{\text{KA}} = 10\text{ mA}$, $T_A = -40^\circ\text{C}$ to 85°C	SOT23-3 and TL432 devices		14	34	mV
		All other devices		5	50		
$\frac{\Delta V_{\text{ref}}}{\Delta V_{\text{KA}}}$ Ratio of change in reference voltage to the change in cathode voltage	3	$I_{\text{KA}} = 10\text{ mA}$	$\Delta V_{\text{KA}} = 10\text{ V} - V_{\text{ref}}$		-1.4	-2.7	$\frac{\text{mV}}{\text{V}}$
			$\Delta V_{\text{KA}} = 36\text{ V} - 10\text{ V}$		-1	-2	
I_{ref} Reference current	3	$I_{\text{KA}} = 10\text{ mA}$, $R_1 = 10\text{ k}\Omega$, $R_2 = \infty$			2	4	μA
$I_{\text{I(dev)}}$ Deviation of reference current over full temperature range (see Figure 1)	3	$I_{\text{KA}} = 10\text{ mA}$, $R_1 = 10\text{ k}\Omega$, $R_2 = \infty$, $T_A = -40^\circ\text{C}$ to 85°C			0.8	2.5	μA
I_{min} Minimum cathode current for regulation	2	$V_{\text{KA}} = V_{\text{ref}}$			0.4	1	mA
I_{off} Off-state cathode current	4	$V_{\text{KA}} = 36\text{ V}$, $V_{\text{ref}} = 0$			0.1	1	μA
$ z_{\text{KA}} $ Dynamic impedance (see Figure 1)	2	$I_{\text{KA}} = 1\text{ mA}$ to 100 mA , $V_{\text{KA}} = V_{\text{ref}}$, $f \leq 1\text{ kHz}$			0.2	0.5	Ω

electrical characteristics over recommended operating conditions, $T_A = 25^\circ\text{C}$ (unless otherwise noted)

PARAMETER	TEST CIRCUIT	TEST CONDITIONS	TL431Q TL432Q			UNIT	
			MIN	TYP	MAX		
V_{ref} Reference voltage	2	$V_{\text{KA}} = V_{\text{ref}}$, $I_{\text{KA}} = 10\text{ mA}$	2440	2495	2550	mV	
$V_{\text{I(dev)}}$ Deviation of reference voltage over full temperature range (see Figure 1)	2	$V_{\text{KA}} = V_{\text{ref}}$, $I_{\text{KA}} = 10\text{ mA}$, $T_A = -40^\circ\text{C}$ to 125°C			14	34	mV
$\frac{\Delta V_{\text{ref}}}{\Delta V_{\text{KA}}}$ Ratio of change in reference voltage to the change in cathode voltage	3	$I_{\text{KA}} = 10\text{ mA}$	$\Delta V_{\text{KA}} = 10\text{ V} - V_{\text{ref}}$		-1.4	-2.7	$\frac{\text{mV}}{\text{V}}$
			$\Delta V_{\text{KA}} = 36\text{ V} - 10\text{ V}$		-1	-2	
I_{ref} Reference current	3	$I_{\text{KA}} = 10\text{ mA}$, $R_1 = 10\text{ k}\Omega$, $R_2 = \infty$			2	4	μA
$I_{\text{I(dev)}}$ Deviation of reference current over full temperature range (see Figure 1)	3	$I_{\text{KA}} = 10\text{ mA}$, $R_1 = 10\text{ k}\Omega$, $R_2 = \infty$, $T_A = -40^\circ\text{C}$ to 125°C			0.8	2.5	μA
I_{min} Minimum cathode current for regulation	2	$V_{\text{KA}} = V_{\text{ref}}$			0.4	1	mA
I_{off} Off-state cathode current	4	$V_{\text{KA}} = 36\text{ V}$, $V_{\text{ref}} = 0$			0.1	1	μA
$ z_{\text{KA}} $ Dynamic impedance (see Figure 1)	2	$I_{\text{KA}} = 1\text{ mA}$ to 100 mA , $V_{\text{KA}} = V_{\text{ref}}$, $f \leq 1\text{ kHz}$			0.2	0.5	Ω



TL431, TL431A, TL431B
TL432, TL432A, TL432B
ADJUSTABLE PRECISION SHUNT REGULATORS

SLVS543I – AUGUST 2004 – REVISED MAY 2005

electrical characteristics over recommended operating conditions, $T_A = 25^\circ\text{C}$ (unless otherwise noted)

PARAMETER	TEST CIRCUIT	TEST CONDITIONS	TL431AC TL432AC			UNIT	
			MIN	TYP	MAX		
V_{ref} Reference voltage	2	$V_{\text{KA}} = V_{\text{ref}}$, $I_{\text{KA}} = 10\text{ mA}$	2470	2495	2520	mV	
$V_{\text{I(dev)}}$ Deviation of reference voltage over full temperature range (see Figure 1)	2	$V_{\text{KA}} = V_{\text{ref}}$, $I_{\text{KA}} = 10\text{ mA}$, $T_A = 0^\circ\text{C}$ to 70°C	SOT23-3, SC-70, and TL432 devices		6	16	mV
		All other devices		4	25		
$\frac{\Delta V_{\text{ref}}}{\Delta V_{\text{KA}}}$ Ratio of change in reference voltage to the change in cathode voltage	3	$I_{\text{KA}} = 10\text{ mA}$	$\Delta V_{\text{KA}} = 10\text{ V} - V_{\text{ref}}$		-1.4	-2.7	$\frac{\text{mV}}{\text{V}}$
			$\Delta V_{\text{KA}} = 36\text{ V} - 10\text{ V}$		-1	-2	
I_{ref} Reference current	3	$I_{\text{KA}} = 10\text{ mA}$, $R_1 = 10\text{ k}\Omega$, $R_2 = \infty$			2	4	μA
$I_{\text{I(dev)}}$ Deviation of reference current over full temperature range (see Figure 1)	3	$I_{\text{KA}} = 10\text{ mA}$, $R_1 = 10\text{ k}\Omega$, $R_2 = \infty$, $T_A = 0^\circ\text{C}$ to 70°C			0.8	1.2	μA
I_{min} Minimum cathode current for regulation	2	$V_{\text{KA}} = V_{\text{ref}}$			0.4	0.6	mA
I_{off} Off-state cathode current	4	$V_{\text{KA}} = 36\text{ V}$, $V_{\text{ref}} = 0$			0.1	0.5	μA
$ z_{\text{KA}} $ Dynamic impedance (see Figure 1)	1	$I_{\text{KA}} = 1\text{ mA}$ to 100 mA , $V_{\text{KA}} = V_{\text{ref}}$, $f \leq 1\text{ kHz}$			0.2	0.5	Ω

electrical characteristics over recommended operating conditions, $T_A = 25^\circ\text{C}$ (unless otherwise noted)

PARAMETER	TEST CIRCUIT	TEST CONDITIONS	TL431AI TL432AI			UNIT	
			MIN	TYP	MAX		
V_{ref} Reference voltage	2	$V_{\text{KA}} = V_{\text{ref}}$, $I_{\text{KA}} = 10\text{ mA}$	2470	2495	2520	mV	
$V_{\text{I(dev)}}$ Deviation of reference voltage over full temperature range (see Figure 1)	2	$V_{\text{KA}} = V_{\text{ref}}$, $I_{\text{KA}} = 10\text{ mA}$, $T_A = -40^\circ\text{C}$ to 85°C	SOT23-3, SC-70, and TL432 devices		14	34	mV
		All other packages		5	50		
$\frac{\Delta V_{\text{ref}}}{\Delta V_{\text{KA}}}$ Ratio of change in reference voltage to the change in cathode voltage	3	$I_{\text{KA}} = 10\text{ mA}$	$\Delta V_{\text{KA}} = 10\text{ V} - V_{\text{ref}}$		-1.4	-2.7	$\frac{\text{mV}}{\text{V}}$
			$\Delta V_{\text{KA}} = 36\text{ V} - 10\text{ V}$		-1	-2	
I_{ref} Reference current	3	$I_{\text{KA}} = 10\text{ mA}$, $R_1 = 10\text{ k}\Omega$, $R_2 = \infty$			2	4	μA
$I_{\text{I(dev)}}$ Deviation of reference current over full temperature range (see Figure 1)	3	$I_{\text{KA}} = 10\text{ mA}$, $R_1 = 10\text{ k}\Omega$, $R_2 = \infty$, $T_A = -40^\circ\text{C}$ to 85°C			0.8	2.5	μA
I_{min} Minimum cathode current for regulation	2	$V_{\text{KA}} = V_{\text{ref}}$			0.4	0.7	mA
I_{off} Off-state cathode current	4	$V_{\text{KA}} = 36\text{ V}$, $V_{\text{ref}} = 0$			0.1	0.5	μA
$ z_{\text{KA}} $ Dynamic impedance (see Figure 1)	2	$I_{\text{KA}} = 1\text{ mA}$ to 100 mA , $V_{\text{KA}} = V_{\text{ref}}$, $f \leq 1\text{ kHz}$			0.2	0.5	Ω



TL431, TL431A, TL431B
TL432, TL432A, TL432B
ADJUSTABLE PRECISION SHUNT REGULATORS

SLVS543I – AUGUST 2004 – REVISED MAY 2005

electrical characteristics over recommended operating conditions, $T_A = 25^\circ\text{C}$ (unless otherwise noted)

PARAMETER	TEST CIRCUIT	TEST CONDITIONS	TL431AQ TL432AQ			UNIT
			MIN	TYP	MAX	
V_{ref} Reference voltage	2	$V_{\text{KA}} = V_{\text{ref}}, I_{\text{KA}} = 10 \text{ mA}$	2470	2495	2520	mV
$V_{\text{I(dev)}}$ Deviation of reference voltage over full temperature range (see Figure 1)	2	$V_{\text{KA}} = V_{\text{ref}}, I_{\text{KA}} = 10 \text{ mA}, T_A = -40^\circ\text{C} \text{ to } 125^\circ\text{C}$		14	34	mV
$\frac{\Delta V_{\text{ref}}}{\Delta V_{\text{KA}}}$ Ratio of change in reference voltage to the change in cathode voltage	3	$I_{\text{KA}} = 10 \text{ mA}$	$\Delta V_{\text{KA}} = 10 \text{ V} - V_{\text{ref}}$	-1.4	-2.7	$\frac{\text{mV}}{\text{V}}$
			$\Delta V_{\text{KA}} = 36 \text{ V} - 10 \text{ V}$	-1	-2	
I_{ref} Reference current	3	$I_{\text{KA}} = 10 \text{ mA}, R_1 = 10 \text{ k}\Omega, R_2 = \infty$		2	4	μA
$I_{\text{I(dev)}}$ Deviation of reference current over full temperature range (see Figure 1)	3	$I_{\text{KA}} = 10 \text{ mA}, R_1 = 10 \text{ k}\Omega, R_2 = \infty, T_A = -40^\circ\text{C} \text{ to } 125^\circ\text{C}$		0.8	2.5	μA
I_{min} Minimum cathode current for regulation	2	$V_{\text{KA}} = V_{\text{ref}}$		0.4	0.7	mA
I_{off} Off-state cathode current	4	$V_{\text{KA}} = 36 \text{ V}, V_{\text{ref}} = 0$		0.1	0.5	μA
$ z_{\text{KA}} $ Dynamic impedance (see Figure 1)	2	$I_{\text{KA}} = 1 \text{ mA} \text{ to } 100 \text{ mA}, V_{\text{KA}} = V_{\text{ref}}, f \leq 1 \text{ kHz}$		0.2	0.5	Ω

electrical characteristics over recommended operating conditions, $T_A = 25^\circ\text{C}$ (unless otherwise noted)

PARAMETER	TEST CIRCUIT	TEST CONDITIONS	TL431BC TL432BC			UNIT
			MIN	TYP	MAX	
V_{ref} Reference voltage	2	$V_{\text{KA}} = V_{\text{ref}}, I_{\text{KA}} = 10 \text{ mA}$	2483	2495	2507	mV
$V_{\text{I(dev)}}$ Deviation of reference voltage over full temperature range (see Figure 1)	2	$V_{\text{KA}} = V_{\text{ref}}, I_{\text{KA}} = 10 \text{ mA}, T_A = 0^\circ\text{C} \text{ to } 70^\circ\text{C}$		6	16	mV
$\frac{\Delta V_{\text{ref}}}{\Delta V_{\text{KA}}}$ Ratio of change in reference voltage to the change in cathode voltage	3	$I_{\text{KA}} = 10 \text{ mA}$	$\Delta V_{\text{KA}} = 10 \text{ V} - V_{\text{ref}}$	-1.4	-2.7	$\frac{\text{mV}}{\text{V}}$
			$\Delta V_{\text{KA}} = 36 \text{ V} - 10 \text{ V}$	-1	-2	
I_{ref} Reference current	3	$I_{\text{KA}} = 10 \text{ mA}, R_1 = 10 \text{ k}\Omega, R_2 = \infty$		2	4	μA
$I_{\text{I(dev)}}$ Deviation of reference current over full temperature range (see Figure 1)	3	$I_{\text{KA}} = 10 \text{ mA}, R_1 = 10 \text{ k}\Omega, R_2 = \infty, T_A = 0^\circ\text{C} \text{ to } 70^\circ\text{C}$		0.8	1.2	μA
I_{min} Minimum cathode current for regulation	2	$V_{\text{KA}} = V_{\text{ref}}$		0.4	0.6	mA
I_{off} Off-state cathode current	4	$V_{\text{KA}} = 36 \text{ V}, V_{\text{ref}} = 0$		0.1	0.5	μA
$ z_{\text{KA}} $ Dynamic impedance (see Figure 1)	1	$I_{\text{KA}} = 1 \text{ mA} \text{ to } 100 \text{ mA}, V_{\text{KA}} = V_{\text{ref}}, f \leq 1 \text{ kHz}$		0.2	0.5	Ω



TL431, TL431A, TL431B
TL432, TL432A, TL432B
ADJUSTABLE PRECISION SHUNT REGULATORS

SLVS543I – AUGUST 2004 – REVISED MAY 2005

electrical characteristics over recommended operating conditions, $T_A = 25^\circ\text{C}$ (unless otherwise noted)

PARAMETER	TEST CIRCUIT	TEST CONDITIONS	TL431BI TL432BI			UNIT
			MIN	TYP	MAX	
V_{ref} Reference voltage	2	$V_{\text{KA}} = V_{\text{ref}}, I_{\text{KA}} = 10 \text{ mA}$	2483	2495	2507	mV
$V_{\text{I(dev)}}$ Deviation of reference voltage over full temperature range (see Figure 1)	2	$V_{\text{KA}} = V_{\text{ref}}, I_{\text{KA}} = 10 \text{ mA}, T_A = -40^\circ\text{C to } 85^\circ\text{C}$		14	34	mV
$\frac{\Delta V_{\text{ref}}}{\Delta V_{\text{KA}}}$ Ratio of change in reference voltage to the change in cathode voltage	3	$I_{\text{KA}} = 10 \text{ mA}$	$\Delta V_{\text{KA}} = 10 \text{ V} - V_{\text{ref}}$	-1.4	-2.7	$\frac{\text{mV}}{\text{V}}$
			$\Delta V_{\text{KA}} = 36 \text{ V} - 10 \text{ V}$	-1	-2	
I_{ref} Reference current	3	$I_{\text{KA}} = 10 \text{ mA}, R1 = 10 \text{ k}\Omega, R2 = \infty$		2	4	μA
$I_{\text{I(dev)}}$ Deviation of reference current over full temperature range (see Figure 1)	3	$I_{\text{KA}} = 10 \text{ mA}, R1 = 10 \text{ k}\Omega, R2 = \infty, T_A = -40^\circ\text{C to } 85^\circ\text{C}$		0.8	2.5	μA
I_{min} Minimum cathode current for regulation	2	$V_{\text{KA}} = V_{\text{ref}}$		0.4	0.7	mA
I_{off} Off-state cathode current	4	$V_{\text{KA}} = 36 \text{ V}, V_{\text{ref}} = 0$		0.1	0.5	μA
$ z_{\text{KA}} $ Dynamic impedance (see Figure 1)	2	$I_{\text{KA}} = 1 \text{ mA to } 100 \text{ mA}, V_{\text{KA}} = V_{\text{ref}}, f \leq 1 \text{ kHz}$		0.2	0.5	Ω

electrical characteristics over recommended operating conditions, $T_A = 25^\circ\text{C}$ (unless otherwise noted)

PARAMETER	TEST CIRCUIT	TEST CONDITIONS	TL431BQ TL432BQ			UNIT
			MIN	TYP	MAX	
V_{ref} Reference voltage	2	$V_{\text{KA}} = V_{\text{ref}}, I_{\text{KA}} = 10 \text{ mA}$	2483	2495	2507	mV
$V_{\text{I(dev)}}$ Deviation of reference voltage over full temperature range (see Figure 1)	2	$V_{\text{KA}} = V_{\text{ref}}, I_{\text{KA}} = 10 \text{ mA}, T_A = -40^\circ\text{C to } 125^\circ\text{C}$		14	34	mV
$\frac{\Delta V_{\text{ref}}}{\Delta V_{\text{KA}}}$ Ratio of change in reference voltage to the change in cathode voltage	3	$I_{\text{KA}} = 10 \text{ mA}$	$\Delta V_{\text{KA}} = 10 \text{ V} - V_{\text{ref}}$	-1.4	-2.7	$\frac{\text{mV}}{\text{V}}$
			$\Delta V_{\text{KA}} = 36 \text{ V} - 10 \text{ V}$	-1	-2	
I_{ref} Reference current	3	$I_{\text{KA}} = 10 \text{ mA}, R1 = 10 \text{ k}\Omega, R2 = \infty$		2	4	μA
$I_{\text{I(dev)}}$ Deviation of reference current over full temperature range (see Figure 1)	3	$I_{\text{KA}} = 10 \text{ mA}, R1 = 10 \text{ k}\Omega, R2 = \infty, T_A = -40^\circ\text{C to } 125^\circ\text{C}$		0.8	2.5	μA
I_{min} Minimum cathode current for regulation	2	$V_{\text{KA}} = V_{\text{ref}}$		0.4	0.7	mA
I_{off} Off-state cathode current	4	$V_{\text{KA}} = 36 \text{ V}, V_{\text{ref}} = 0$		0.1	0.5	μA
$ z_{\text{KA}} $ Dynamic impedance (see Figure 1)	1	$I_{\text{KA}} = 1 \text{ mA to } 100 \text{ mA}, V_{\text{KA}} = V_{\text{ref}}, f \leq 1 \text{ kHz}$		0.2	0.5	Ω



PARAMETER MEASUREMENT INFORMATION

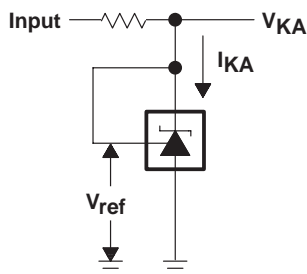

Figure 2. Test Circuit for $V_{KA} = V_{ref}$

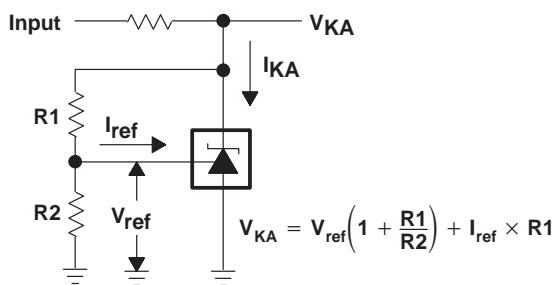

Figure 3. Test Circuit for $V_{KA} > V_{ref}$

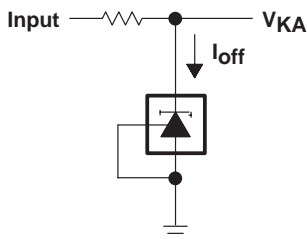

Figure 4. Test Circuit for I_{off}

TL431, TL431A, TL431B
TL432, TL432A, TL432B
ADJUSTABLE PRECISION SHUNT REGULATORS

SLVS543I – AUGUST 2004 – REVISED MAY 2005

TYPICAL CHARACTERISTICS

Table 1. Graphs

	FIGURE
Reference voltage vs Free-air temperature	5
Reference current vs Free-air temperature	6
Cathode current vs Cathode voltage	7, 8
OFF-state cathode current vs Free-air temperature	9
Ratio of delta reference voltage to delta cathode voltage vs Free-air temperature	10
Equivalent input noise voltage vs Frequency	11
Equivalent input noise voltage over a 10-s period	12
Small-signal voltage amplification vs Frequency	13
Reference impedance vs Frequency	14
Pulse response	15
Stability boundary conditions	16

Table 2. Application Circuits

	FIGURE
Shunt regulator	17
Single-supply comparator with temperature-compensated threshold	18
Precision high-current series regulator	19
Output control of a three-terminal fixed regulator	20
High-current shunt regulator	21
Crowbar circuit	22
Precision 5-V 1.5-A regulator	23
Efficient 5-V precision regulator	24
PWM converter with reference	25
Voltage monitor	26
Delay timer	27
Precision current limiter	28
Precision constant-current sink	29

TYPICAL CHARACTERISTICS†

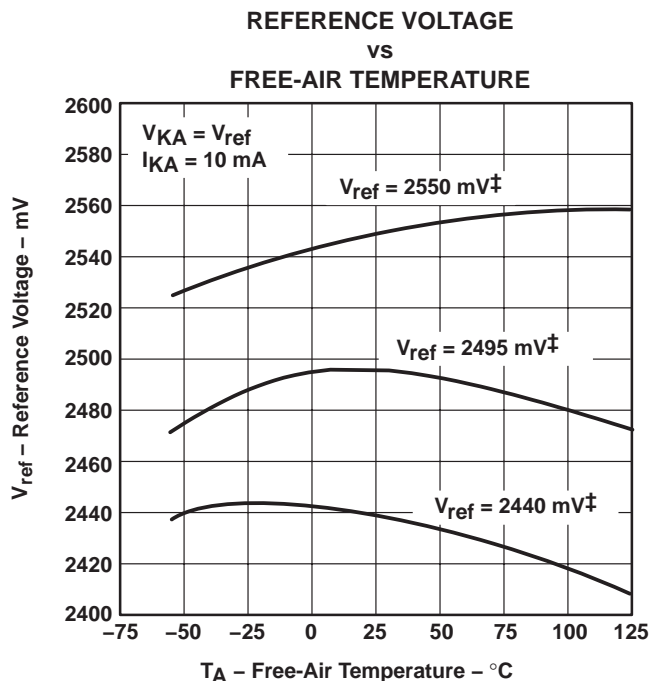

† Data is for devices having the indicated value of V_{ref} at $I_{KA} = 10 \text{ mA}$, $T_A = 25^\circ\text{C}$.

Figure 5

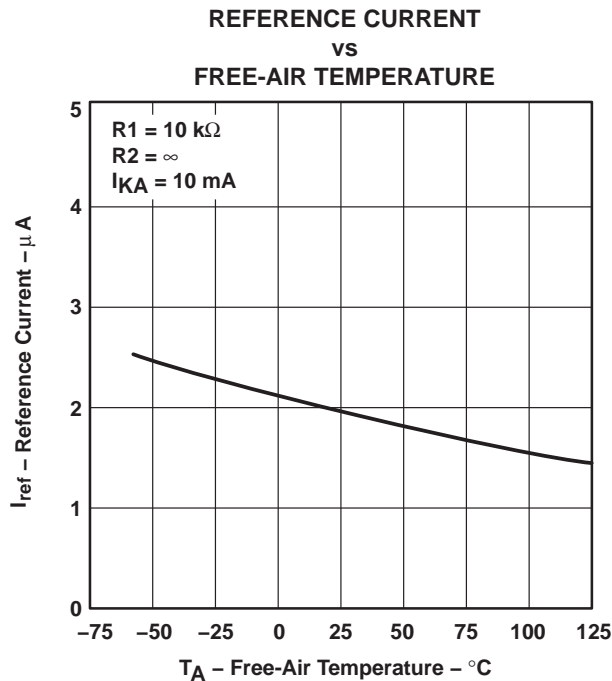

Figure 6

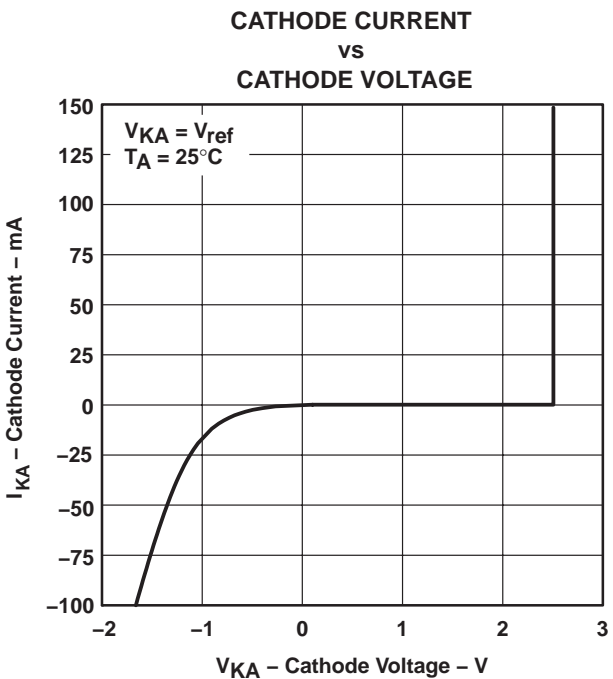

Figure 7

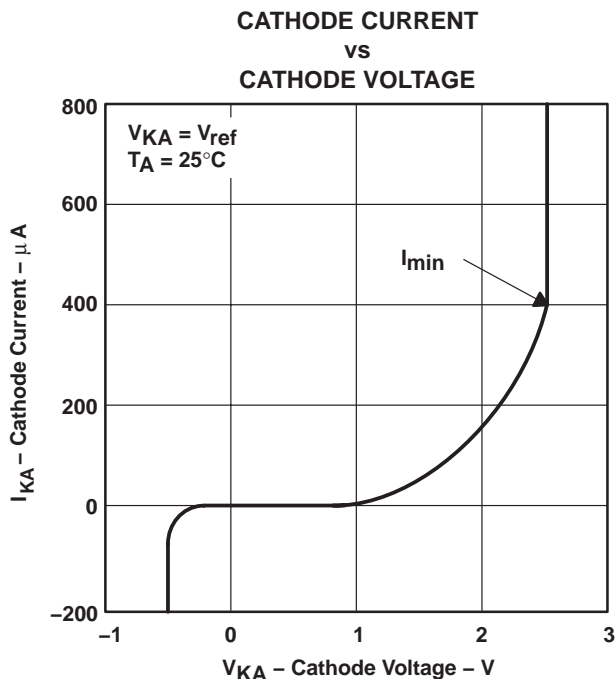

Figure 8

† Data at high and low temperatures is applicable only within the recommended operating free-air temperature ranges of the various devices.

**TL431, TL431A, TL431B
TL432, TL432A, TL432B
ADJUSTABLE PRECISION SHUNT REGULATORS**

SLVS543I – AUGUST 2004 – REVISED MAY 2005

TYPICAL CHARACTERISTICS†

**OFF-STATE CATHODE CURRENT
vs
FREE-AIR TEMPERATURE**

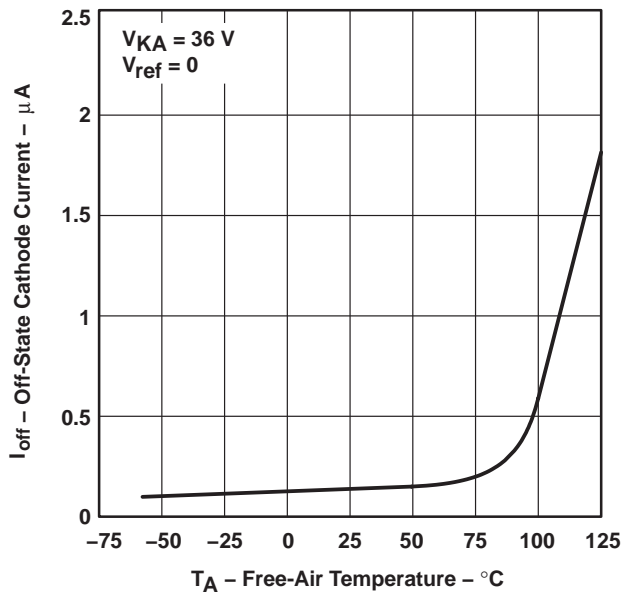

Figure 9

**RATIO OF DELTA REFERENCE VOLTAGE TO
DELTA CATHODE VOLTAGE
vs
FREE-AIR TEMPERATURE**

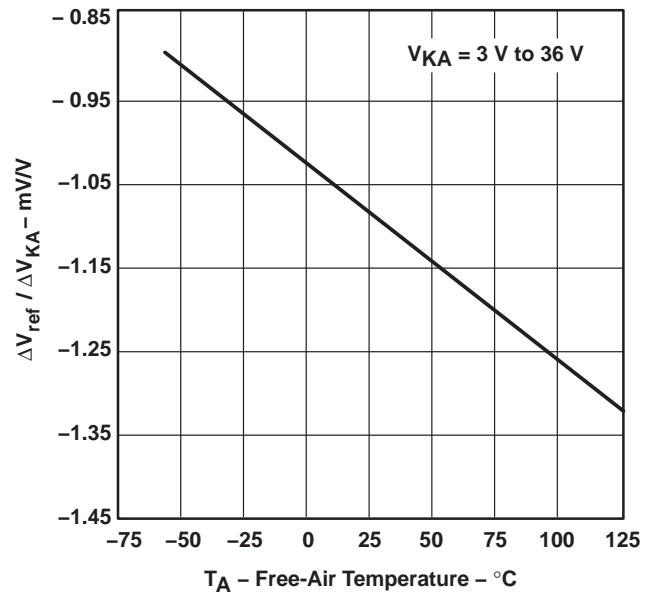

Figure 10

**EQUIVALENT INPUT NOISE VOLTAGE
vs
FREQUENCY**

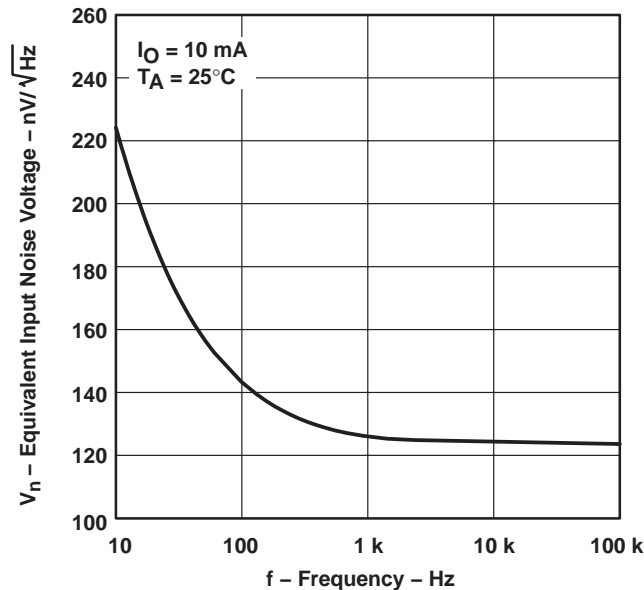

Figure 11

† Data at high and low temperatures is applicable only within the recommended operating free-air temperature ranges of the various devices.

TYPICAL CHARACTERISTICS

EQUIVALENT INPUT NOISE VOLTAGE
 OVER A 10-S PERIOD

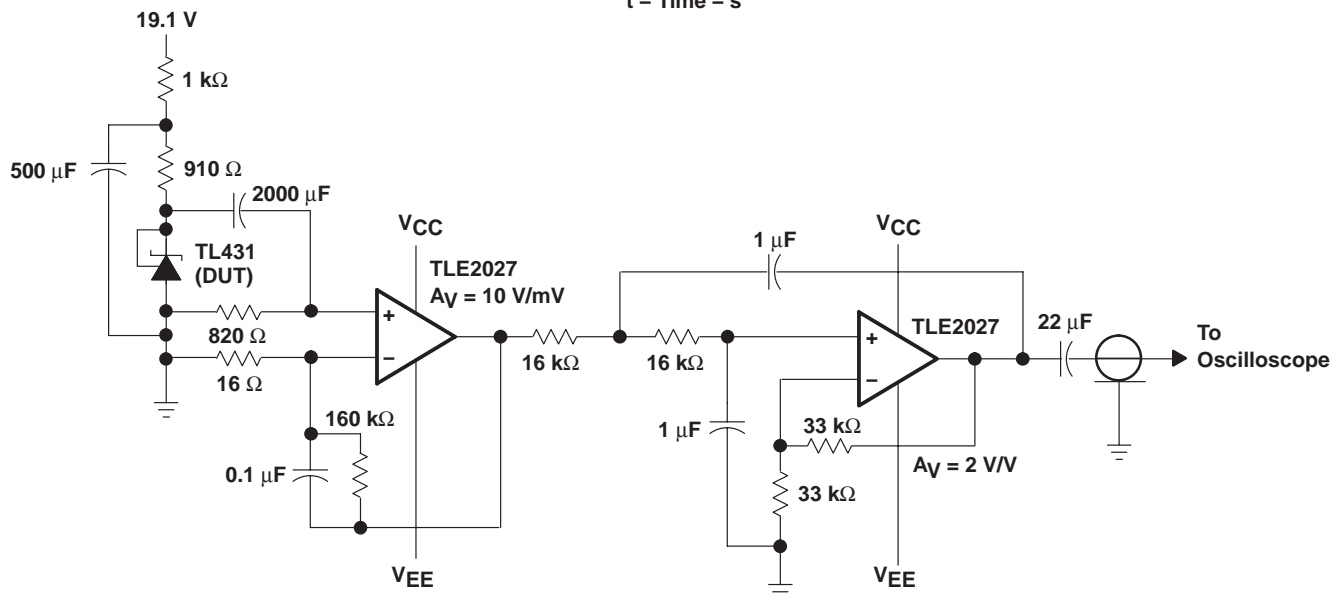
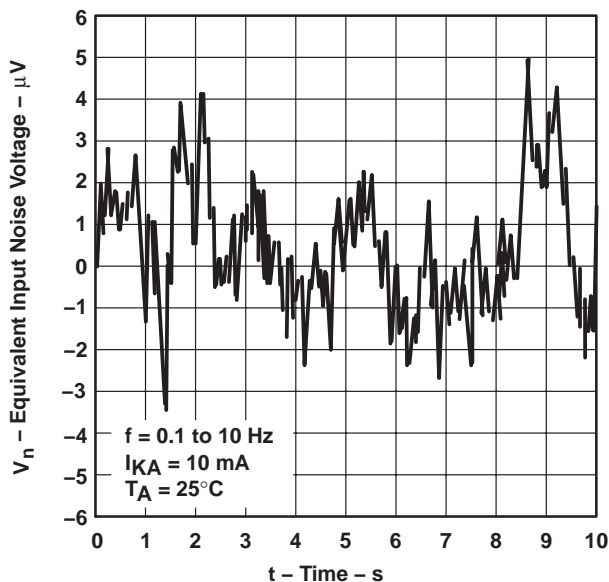

Figure 12. Test Circuit for Equivalent Input Noise Voltage

**TL431, TL431A, TL431B
TL432, TL432A, TL432B
ADJUSTABLE PRECISION SHUNT REGULATORS**

SLVS543I – AUGUST 2004 – REVISED MAY 2005

TYPICAL CHARACTERISTICS

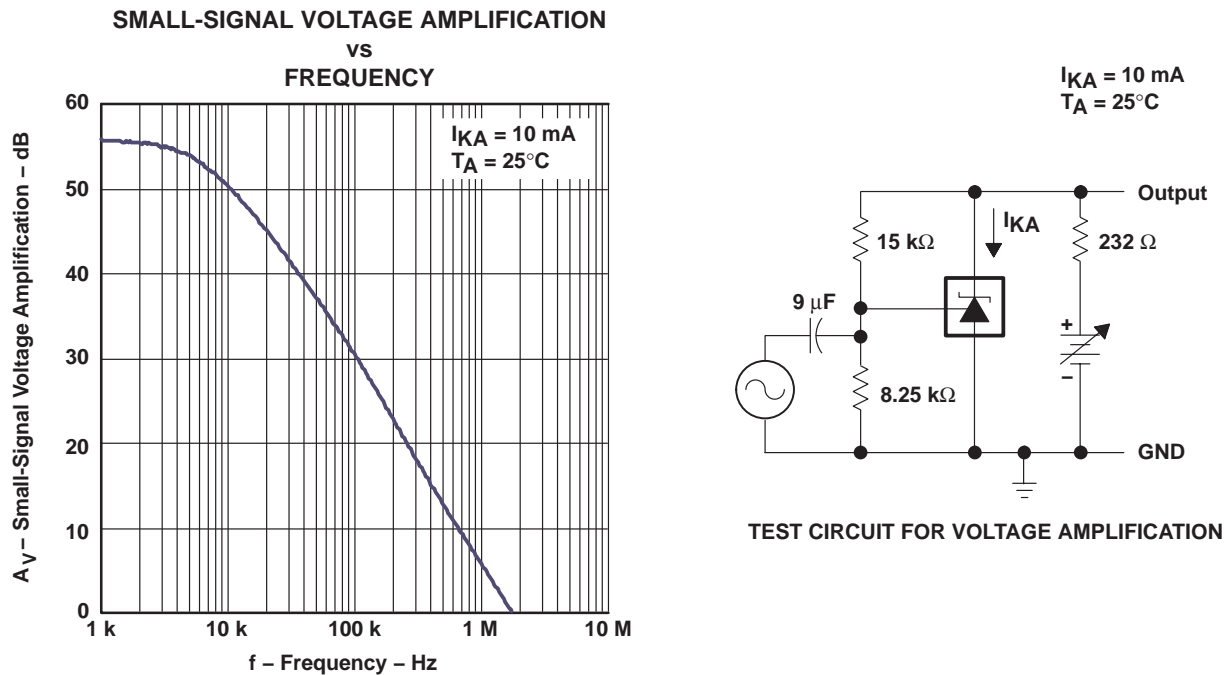

Figure 13

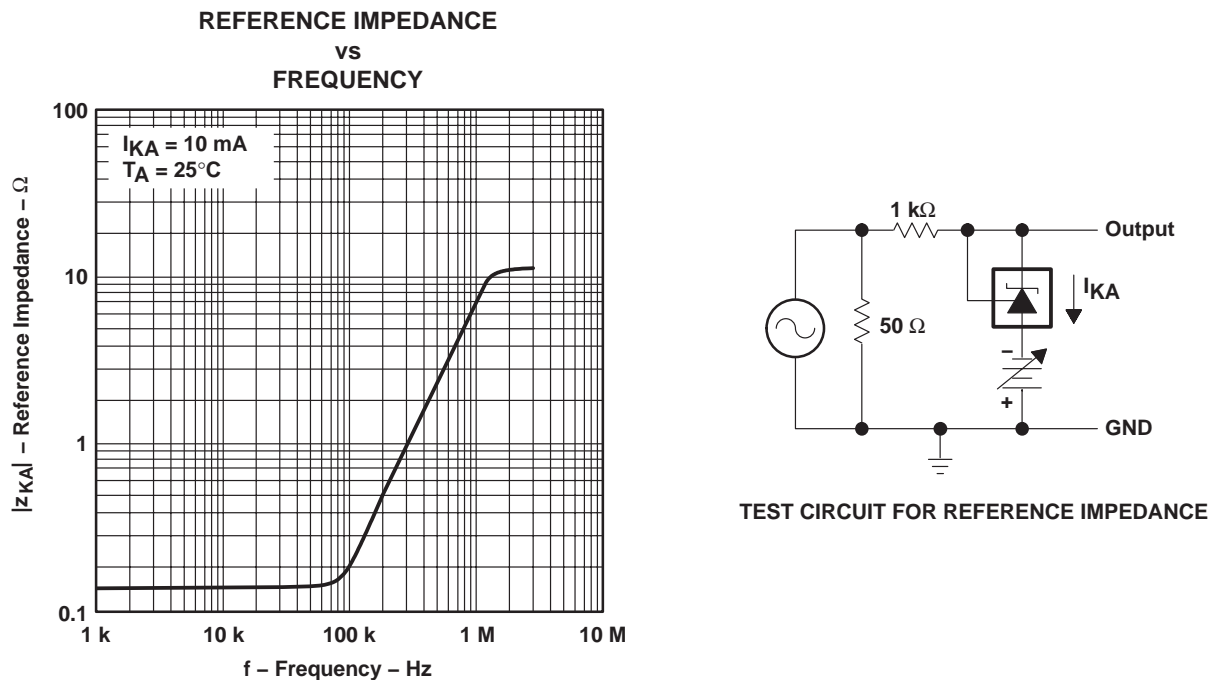

Figure 14

TYPICAL CHARACTERISTICS

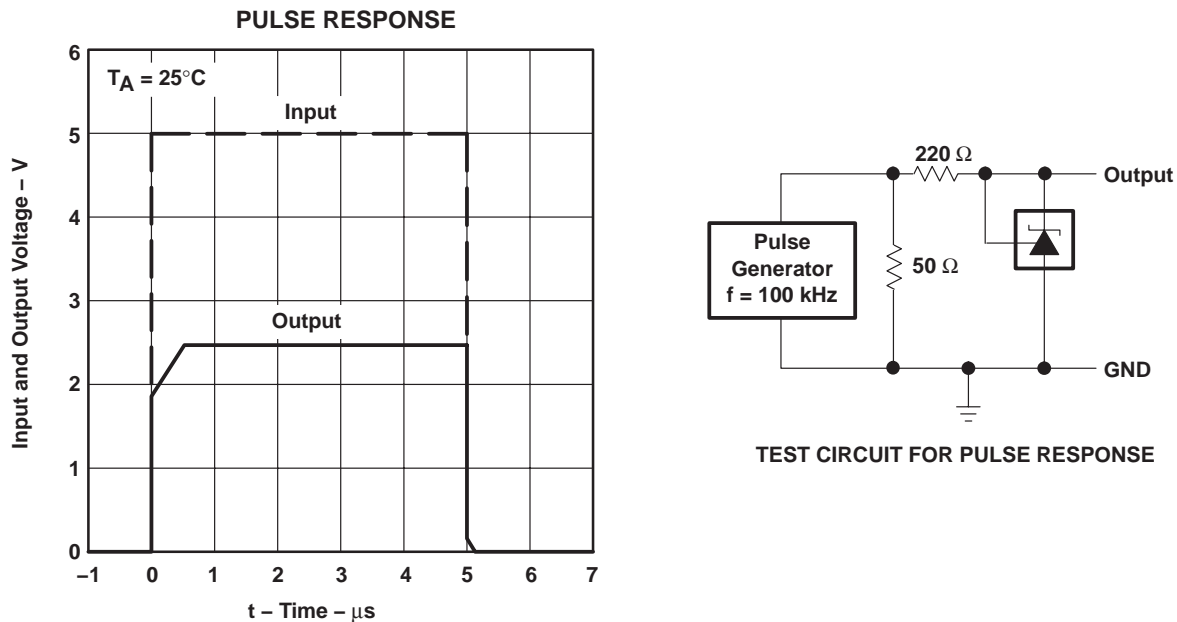

Figure 15

**TL431, TL431A, TL431B
TL432, TL432A, TL432B
ADJUSTABLE PRECISION SHUNT REGULATORS**

SLVS543I – AUGUST 2004 – REVISED MAY 2005

TYPICAL CHARACTERISTICS

**STABILITY BOUNDARY CONDITIONS†
FOR ALL TL431 AND TL431A DEVICES
(EXCEPT FOR SOT23-3, SC-70, AND Q-TEMP DEVICES)**

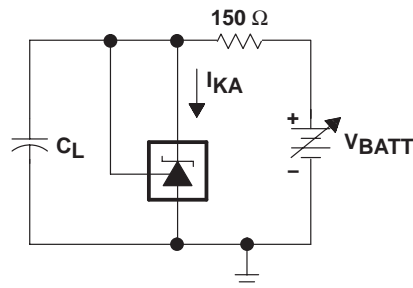
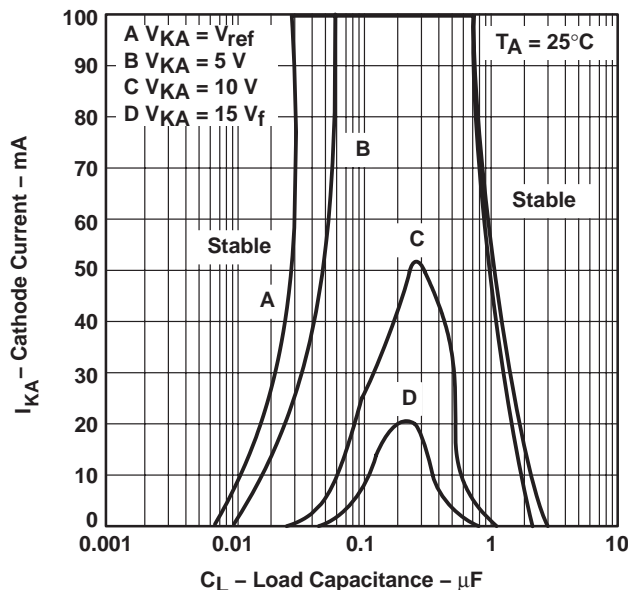

TEST CIRCUIT FOR CURVE A

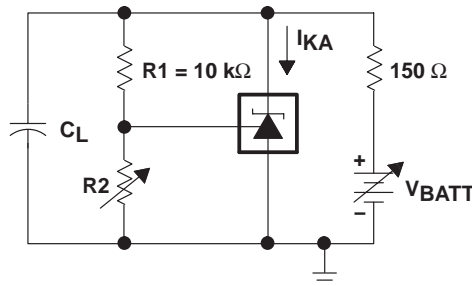

TEST CIRCUIT FOR CURVES B, C, AND D

**STABILITY BOUNDARY CONDITIONS†
FOR ALL TL431B, TL432, SOT-23, SC-70, AND Q-TEMP DEVICES**

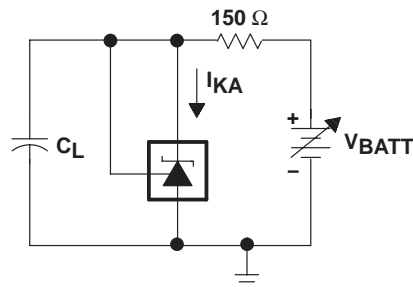
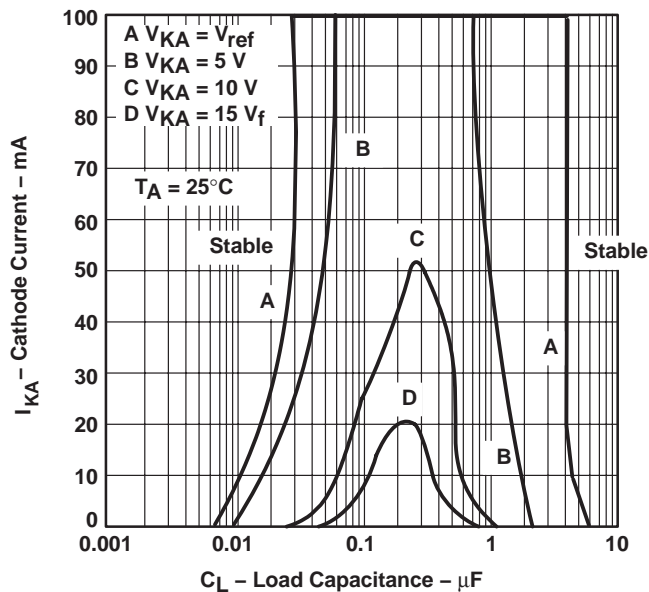

TEST CIRCUIT FOR CURVE A

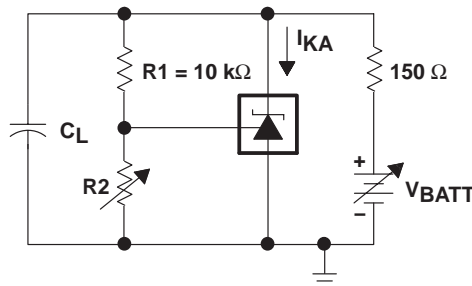

TEST CIRCUIT FOR CURVES B, C, AND D

† The areas under the curves represent conditions that may cause the device to oscillate. For curves B, C, and D, R2 and V+ were adjusted to establish the initial V_{KA} and I_{KA} conditions with $C_L = 0$. V_{BATT} and C_L then were adjusted to determine the ranges of stability.

Figure 16

APPLICATION INFORMATION

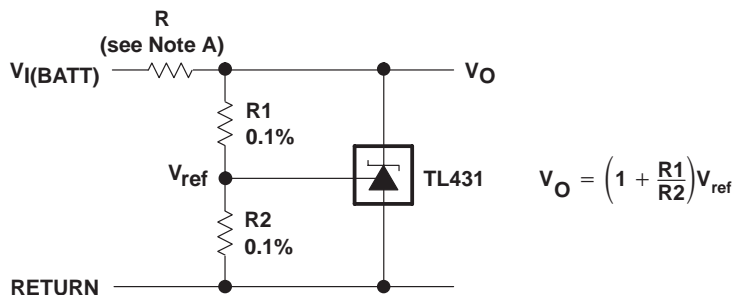

NOTE A: R should provide cathode current ≥ 1 mA to the TL431 at minimum $V_{I(BATT)}$.

Figure 17. Shunt Regulator

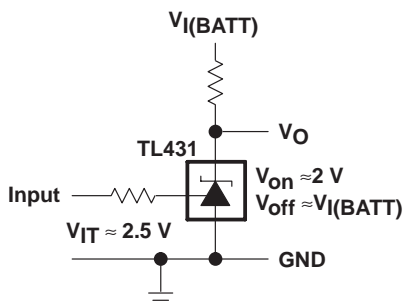
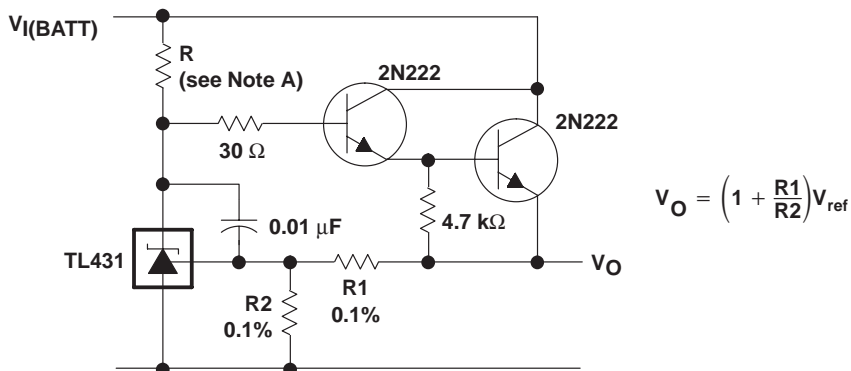

Figure 18. Single-Supply Comparator With Temperature-Compensated Threshold



NOTE A: R should provide cathode current ≥ 1 mA to the TL431 at minimum $V_{I(BATT)}$.

Figure 19. Precision High-Current Series Regulator

**TL431, TL431A, TL431B
TL432, TL432A, TL432B
ADJUSTABLE PRECISION SHUNT REGULATORS**

SLVS5431 – AUGUST 2004 – REVISED MAY 2005

APPLICATION INFORMATION

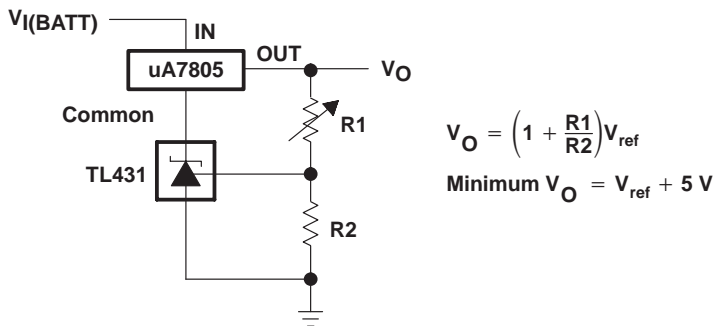

Figure 20. Output Control of a Three-Terminal Fixed Regulator

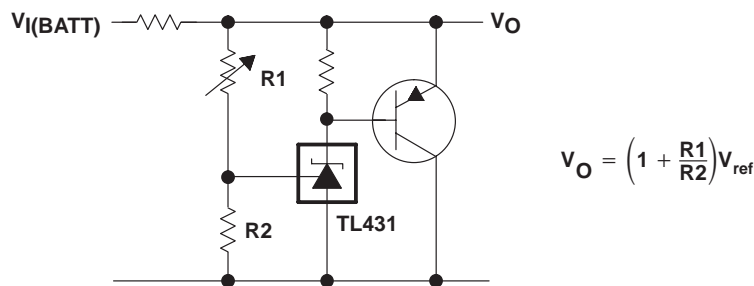
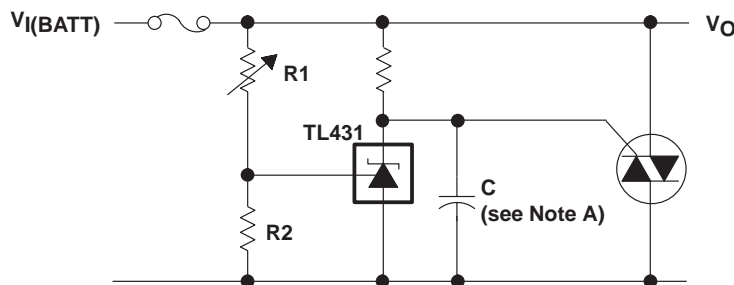

Figure 21. High-Current Shunt Regulator



NOTE A: Refer to the stability boundary conditions in Figure 16 to determine allowable values for C.

Figure 22. Crowbar Circuit

APPLICATION INFORMATION

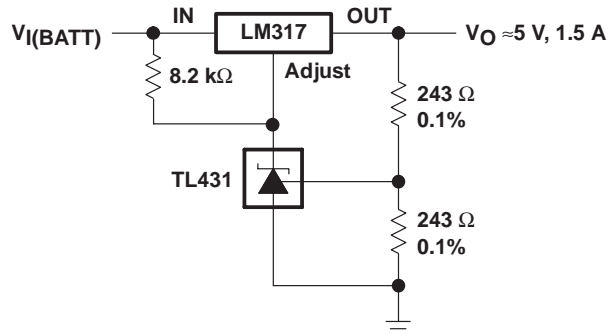
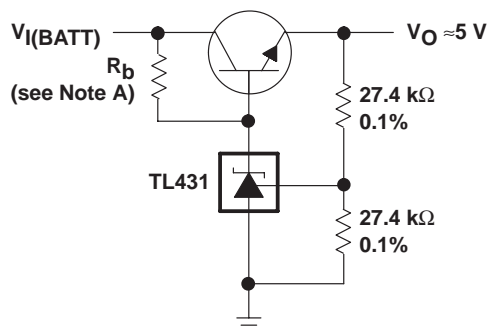

Figure 23. Precision 5-V 1.5-A Regulator



NOTE A: R_b should provide cathode current ≥ 1 mA to the TL431.

Figure 24. Efficient 5-V Precision Regulator

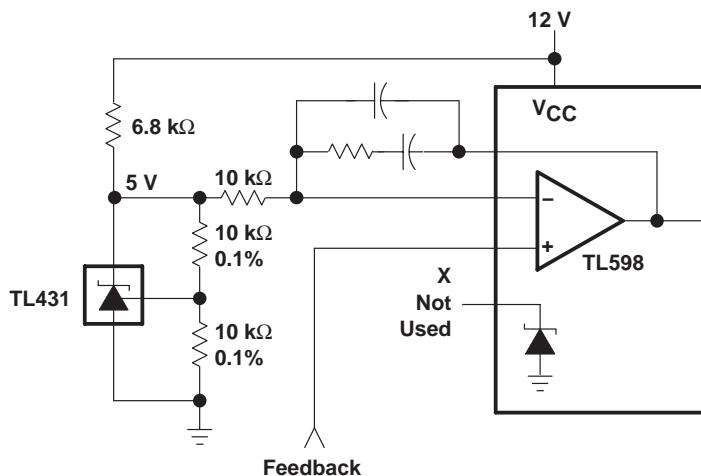
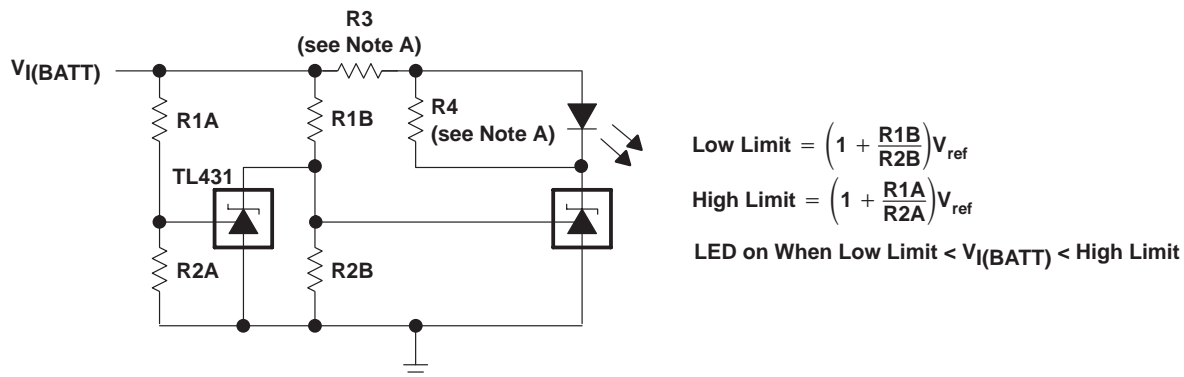

Figure 25. PWM Converter With Reference

**TL431, TL431A, TL431B
TL432, TL432A, TL432B
ADJUSTABLE PRECISION SHUNT REGULATORS**

SLVS543I – AUGUST 2004 – REVISED MAY 2005

APPLICATION INFORMATION



NOTE A: R3 and R4 are selected to provide the desired LED intensity and cathode current ≥ 1 mA to the TL431 at the available $V_{I(BATT)}$.

Figure 26. Voltage Monitor

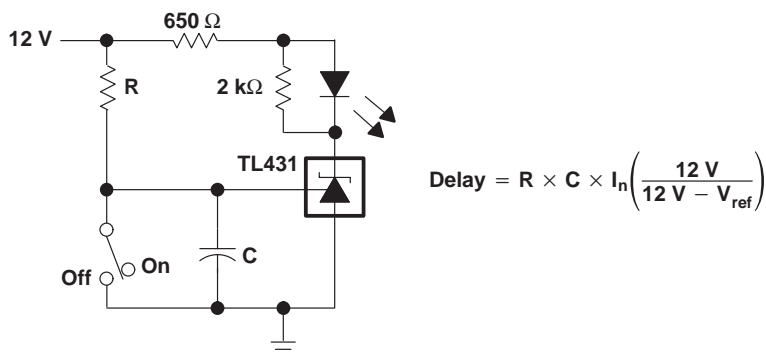

Figure 27. Delay Timer

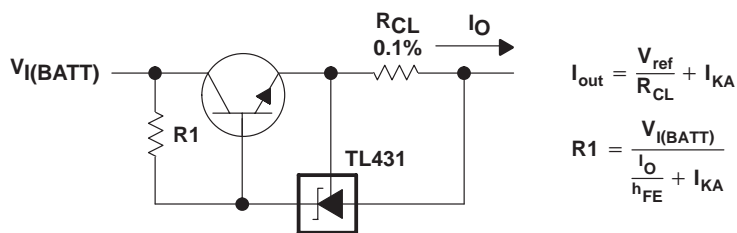

Figure 28. Precision Current Limiter

APPLICATION INFORMATION

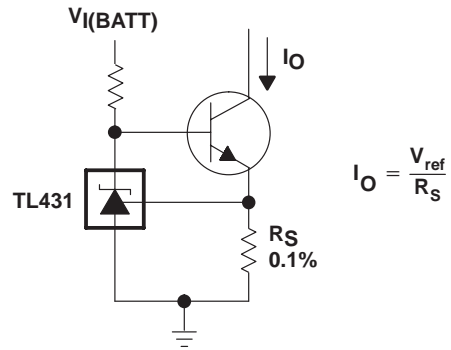

Figure 29. Precision Constant-Current Sink

PACKAGING INFORMATION

Orderable Device	Status ⁽¹⁾	Package Type	Package Drawing	Pins	Package Qty	Eco Plan ⁽²⁾	Lead/Ball Finish	MSL Peak Temp ⁽³⁾
TL431ACD	ACTIVE	SOIC	D	8	75	Green (RoHS & no Sb/Br)	CU NIPDAU	Level-1-260C-UNLIM
TL431ACDBVR	ACTIVE	SOT-23	DBV	5	3000	Green (RoHS & no Sb/Br)	CU NIPDAU	Level-1-260C-UNLIM
TL431ACDBVRG4	ACTIVE	SOT-23	DBV	5	3000	Green (RoHS & no Sb/Br)	CU NIPDAU	Level-1-260C-UNLIM
TL431ACDBVT	ACTIVE	SOT-23	DBV	5	250	Green (RoHS & no Sb/Br)	CU NIPDAU	Level-1-260C-UNLIM
TL431ACDBVTE4	ACTIVE	SOT-23	DBV	5	250	Green (RoHS & no Sb/Br)	CU NIPDAU	Level-1-260C-UNLIM
TL431ACDBZR	ACTIVE	SOT-23	DBZ	3	3000	Green (RoHS & no Sb/Br)	CU NIPDAU	Level-1-260C-UNLIM
TL431ACDBZRG4	ACTIVE	SOT-23	DBZ	3	3000	Green (RoHS & no Sb/Br)	CU NIPDAU	Level-1-260C-UNLIM
TL431ACDBZT	ACTIVE	SOT-23	DBZ	3	250	Green (RoHS & no Sb/Br)	CU NIPDAU	Level-1-260C-UNLIM
TL431ACDBZTG4	ACTIVE	SOT-23	DBZ	3	250	Green (RoHS & no Sb/Br)	CU NIPDAU	Level-1-260C-UNLIM
TL431ACDCKR	ACTIVE	SC70	DCK	6	3000	Green (RoHS & no Sb/Br)	CU NIPDAU	Level-1-260C-UNLIM
TL431ACDCKRE4	ACTIVE	SC70	DCK	6	3000	Green (RoHS & no Sb/Br)	CU NIPDAU	Level-1-260C-UNLIM
TL431ACDCKT	ACTIVE	SC70	DCK	6	250	Green (RoHS & no Sb/Br)	CU NIPDAU	Level-1-260C-UNLIM
TL431ACDCKTE4	ACTIVE	SC70	DCK	6	250	Green (RoHS & no Sb/Br)	CU NIPDAU	Level-1-260C-UNLIM
TL431ACDG4	ACTIVE	SOIC	D	8	75	Green (RoHS & no Sb/Br)	CU NIPDAU	Level-1-260C-UNLIM
TL431ACDR	ACTIVE	SOIC	D	8	2500	Green (RoHS & no Sb/Br)	CU NIPDAU	Level-1-260C-UNLIM
TL431ACDRG4	ACTIVE	SOIC	D	8	2500	Green (RoHS & no Sb/Br)	CU NIPDAU	Level-1-260C-UNLIM
TL431ACLCP	ACTIVE	TO-92	LP	3	1000	TBD	CU SNPB	Level-NC-NC-NC
TL431ACLPM	ACTIVE	TO-92	LP	3	2000	TBD	CU SNPB	Level-NC-NC-NC
TL431ACLPR	ACTIVE	TO-92	LP	3	2000	TBD	CU SNPB	Level-NC-NC-NC
TL431ACP	ACTIVE	PDIP	P	8	50	Pb-Free (RoHS)	CU NIPDAU	Level-NC-NC-NC
TL431ACPK	ACTIVE	SOT-89	PK	3	1000	TBD	CU SNPB	Level-1-220C-UNLIM
TL431ACPSR	ACTIVE	SO	PS	8	2000	Green (RoHS & no Sb/Br)	CU NIPDAU	Level-1-260C-UNLIM
TL431ACPSRE4	ACTIVE	SO	PS	8	2000	Green (RoHS & no Sb/Br)	CU NIPDAU	Level-1-260C-UNLIM
TL431ACPW	ACTIVE	TSSOP	PW	8	150	Green (RoHS & no Sb/Br)	CU NIPDAU	Level-1-260C-UNLIM
TL431ACPWE4	ACTIVE	TSSOP	PW	8	150	Green (RoHS & no Sb/Br)	CU NIPDAU	Level-1-260C-UNLIM
TL431ACPWR	ACTIVE	TSSOP	PW	8	2000	Green (RoHS & no Sb/Br)	CU NIPDAU	Level-1-260C-UNLIM
TL431AID	ACTIVE	SOIC	D	8	75	Green (RoHS & no Sb/Br)	CU NIPDAU	Level-1-260C-UNLIM

Orderable Device	Status ⁽¹⁾	Package Type	Package Drawing	Pins	Package Qty	Eco Plan ⁽²⁾	Lead/Ball Finish	MSL Peak Temp ⁽³⁾
						no Sb/Br)		
TL431AIDBVR	ACTIVE	SOT-23	DBV	5	3000	Green (RoHS & no Sb/Br)	CU NIPDAU	Level-1-260C-UNLIM
TL431AIDBVT	ACTIVE	SOT-23	DBV	5	250	Green (RoHS & no Sb/Br)	CU NIPDAU	Level-1-260C-UNLIM
TL431AIDBVTE4	ACTIVE	SOT-23	DBV	5	250	Green (RoHS & no Sb/Br)	CU NIPDAU	Level-1-260C-UNLIM
TL431AIDBZR	ACTIVE	SOT-23	DBZ	3	3000	Green (RoHS & no Sb/Br)	CU NIPDAU	Level-1-260C-UNLIM
TL431AIDBZRG4	ACTIVE	SOT-23	DBZ	3	3000	Green (RoHS & no Sb/Br)	CU NIPDAU	Level-1-260C-UNLIM
TL431AIDBZT	ACTIVE	SOT-23	DBZ	3	250	Green (RoHS & no Sb/Br)	CU NIPDAU	Level-1-260C-UNLIM
TL431AIDBZTG4	ACTIVE	SOT-23	DBZ	3	250	Green (RoHS & no Sb/Br)	CU NIPDAU	Level-1-260C-UNLIM
TL431AIDCKR	ACTIVE	SC70	DCK	6	3000	Green (RoHS & no Sb/Br)	CU NIPDAU	Level-1-260C-UNLIM
TL431AIDCKRE4	ACTIVE	SC70	DCK	6	3000	Green (RoHS & no Sb/Br)	CU NIPDAU	Level-1-260C-UNLIM
TL431AIDCKT	ACTIVE	SC70	DCK	6	250	Green (RoHS & no Sb/Br)	CU NIPDAU	Level-1-260C-UNLIM
TL431AIDCKTE4	ACTIVE	SC70	DCK	6	250	Green (RoHS & no Sb/Br)	CU NIPDAU	Level-1-260C-UNLIM
TL431AIDG4	ACTIVE	SOIC	D	8	75	Green (RoHS & no Sb/Br)	CU NIPDAU	Level-1-260C-UNLIM
TL431AIDR	ACTIVE	SOIC	D	8	2500	Green (RoHS & no Sb/Br)	CU NIPDAU	Level-1-260C-UNLIM
TL431AIDRG4	ACTIVE	SOIC	D	8	2500	Green (RoHS & no Sb/Br)	CU NIPDAU	Level-1-260C-UNLIM
TL431AILP	ACTIVE	TO-92	LP	3	1000	TBD	CU SNPB	Level-NC-NC-NC
TL431AILPM	ACTIVE	TO-92	LP	3	2000	TBD	CU SNPB	Level-NC-NC-NC
TL431AILPR	ACTIVE	TO-92	LP	3	2000	TBD	CU SNPB	Level-NC-NC-NC
TL431AIP	ACTIVE	PDIP	P	8	50	Pb-Free (RoHS)	CU NIPDAU	Level-NC-NC-NC
TL431AIPK	ACTIVE	SOT-89	PK	3	1000	TBD	CU SNPB	Level-1-220C-UNLIM
TL431AIPKG3	ACTIVE	SOT-89	PK	3	1000	Green (RoHS & no Sb/Br)	CU SN	Level-2-260C-1YEAR
TL431AQDBVR	ACTIVE	SOT-23	DBV	5	3000	Green (RoHS & no Sb/Br)	CU NIPDAU	Level-1-260C-UNLIM
TL431AQDBVRE4	ACTIVE	SOT-23	DBV	5	3000	Green (RoHS & no Sb/Br)	CU NIPDAU	Level-1-260C-UNLIM
TL431AQDBVT	ACTIVE	SOT-23	DBV	5	250	Green (RoHS & no Sb/Br)	CU NIPDAU	Level-1-260C-UNLIM
TL431AQDBVTE4	ACTIVE	SOT-23	DBV	5	250	Green (RoHS & no Sb/Br)	CU NIPDAU	Level-1-260C-UNLIM
TL431AQDBZR	ACTIVE	SOT-23	DBZ	3	3000	Green (RoHS & no Sb/Br)	CU NIPDAU	Level-1-260C-UNLIM
TL431AQDBZRG4	ACTIVE	SOT-23	DBZ	3	3000	Green (RoHS & no Sb/Br)	CU NIPDAU	Level-1-260C-UNLIM
TL431AQDBZT	ACTIVE	SOT-23	DBZ	3	250	Green (RoHS & no Sb/Br)	CU NIPDAU	Level-1-260C-UNLIM

Orderable Device	Status ⁽¹⁾	Package Type	Package Drawing	Pins	Package Qty	Eco Plan ⁽²⁾	Lead/Ball Finish	MSL Peak Temp ⁽³⁾
TL431AQDBZTG4	ACTIVE	SOT-23	DBZ	3	250	Green (RoHS & no Sb/Br)	CU NIPDAU	Level-1-260C-UNLIM
TL431AQDCKR	ACTIVE	SC70	DCK	6	3000	Green (RoHS & no Sb/Br)	CU NIPDAU	Level-1-260C-UNLIM
TL431AQDCKRE4	ACTIVE	SC70	DCK	6	3000	Green (RoHS & no Sb/Br)	CU NIPDAU	Level-1-260C-UNLIM
TL431AQDCKT	ACTIVE	SC70	DCK	6	250	Green (RoHS & no Sb/Br)	CU NIPDAU	Level-1-260C-UNLIM
TL431AQDCKTE4	ACTIVE	SC70	DCK	6	250	Green (RoHS & no Sb/Br)	CU NIPDAU	Level-1-260C-UNLIM
TL431AQPCK	ACTIVE	SOT-89	PK	3	1000	TBD	CU SNPB	Level-1-220C-UNLIM
TL431AQPCKG3	ACTIVE	SOT-89	PK	3	1000	Green (RoHS & no Sb/Br)	CU SN	Level-2-260C-1YEAR
TL431BCD	ACTIVE	SOIC	D	8	75	Green (RoHS & no Sb/Br)	CU NIPDAU	Level-1-260C-UNLIM
TL431BCDBVR	ACTIVE	SOT-23	DBV	5	3000	Green (RoHS & no Sb/Br)	CU NIPDAU	Level-1-260C-UNLIM
TL431BCDBVRE4	ACTIVE	SOT-23	DBV	5	3000	Green (RoHS & no Sb/Br)	CU NIPDAU	Level-1-260C-UNLIM
TL431BCDBVT	ACTIVE	SOT-23	DBV	5	250	Green (RoHS & no Sb/Br)	CU NIPDAU	Level-1-260C-UNLIM
TL431BCDBVTE4	ACTIVE	SOT-23	DBV	5	250	Green (RoHS & no Sb/Br)	CU NIPDAU	Level-1-260C-UNLIM
TL431BCDBZR	ACTIVE	SOT-23	DBZ	3	3000	Green (RoHS & no Sb/Br)	CU NIPDAU	Level-1-260C-UNLIM
TL431BCDBZRG4	ACTIVE	SOT-23	DBZ	3	3000	Green (RoHS & no Sb/Br)	CU NIPDAU	Level-1-260C-UNLIM
TL431BCDBZT	ACTIVE	SOT-23	DBZ	3	250	Green (RoHS & no Sb/Br)	CU NIPDAU	Level-1-260C-UNLIM
TL431BCDBZTG4	ACTIVE	SOT-23	DBZ	3	250	Green (RoHS & no Sb/Br)	CU NIPDAU	Level-1-260C-UNLIM
TL431BCDCKR	ACTIVE	SC70	DCK	6	3000	Green (RoHS & no Sb/Br)	CU NIPDAU	Level-1-260C-UNLIM
TL431BCDCKRE4	ACTIVE	SC70	DCK	6	3000	Green (RoHS & no Sb/Br)	CU NIPDAU	Level-1-260C-UNLIM
TL431BCDCKT	ACTIVE	SC70	DCK	6	250	Green (RoHS & no Sb/Br)	CU NIPDAU	Level-1-260C-UNLIM
TL431BCDCKTE4	ACTIVE	SC70	DCK	6	250	Green (RoHS & no Sb/Br)	CU NIPDAU	Level-1-260C-UNLIM
TL431BCDE4	ACTIVE	SOIC	D	8	75	Green (RoHS & no Sb/Br)	CU NIPDAU	Level-1-260C-UNLIM
TL431BCDR	ACTIVE	SOIC	D	8	2500	Green (RoHS & no Sb/Br)	CU NIPDAU	Level-1-260C-UNLIM
TL431BCDRE4	ACTIVE	SOIC	D	8	2500	Green (RoHS & no Sb/Br)	CU NIPDAU	Level-1-260C-UNLIM
TL431BCLP	ACTIVE	TO-92	LP	3	1000	TBD	CU SNPB	Level-NC-NC-NC
TL431BCLPM	ACTIVE	TO-92	LP	3	2000	TBD	CU SNPB	Level-NC-NC-NC
TL431BCLPR	ACTIVE	TO-92	LP	3	2000	TBD	CU SNPB	Level-NC-NC-NC
TL431BCP	ACTIVE	PDIP	P	8	50	Pb-Free (RoHS)	CU NIPDAU	Level-NC-NC-NC
TL431BCPE4	ACTIVE	PDIP	P	8	50	Pb-Free	CU NIPDAU	Level-NC-NC-NC

Orderable Device	Status ⁽¹⁾	Package Type	Package Drawing	Pins	Package Qty	Eco Plan ⁽²⁾	Lead/Ball Finish	MSL Peak Temp ⁽³⁾
(RoHS)								
TL431BCPK	ACTIVE	SOT-89	PK	3	1000	TBD	CU SNPB	Level-1-220C-UNLIM
TL431BCPKG3	ACTIVE	SOT-89	PK	3	1000	Green (RoHS & no Sb/Br)	CU SN	Level-2-260C-1YEAR
TL431BCPSR	ACTIVE	SO	PS	8	2000	Green (RoHS & no Sb/Br)	CU NIPDAU	Level-1-260C-UNLIM
TL431BCPSRE4	ACTIVE	SO	PS	8	2000	Green (RoHS & no Sb/Br)	CU NIPDAU	Level-1-260C-UNLIM
TL431BCPW	ACTIVE	TSSOP	PW	8	150	Green (RoHS & no Sb/Br)	CU NIPDAU	Level-1-260C-UNLIM
TL431BCPWE4	ACTIVE	TSSOP	PW	8	150	Green (RoHS & no Sb/Br)	CU NIPDAU	Level-1-260C-UNLIM
TL431BCPWR	ACTIVE	TSSOP	PW	8	2000	Green (RoHS & no Sb/Br)	CU NIPDAU	Level-1-260C-UNLIM
TL431BCPWRE4	ACTIVE	TSSOP	PW	8	2000	Green (RoHS & no Sb/Br)	CU NIPDAU	Level-1-260C-UNLIM
TL431BID	ACTIVE	SOIC	D	8	75	Green (RoHS & no Sb/Br)	CU NIPDAU	Level-1-260C-UNLIM
TL431BIDBVR	ACTIVE	SOT-23	DBV	5	3000	Green (RoHS & no Sb/Br)	CU NIPDAU	Level-1-260C-UNLIM
TL431BIDBvre4	ACTIVE	SOT-23	DBV	5	3000	Green (RoHS & no Sb/Br)	CU NIPDAU	Level-1-260C-UNLIM
TL431BIDBVT	ACTIVE	SOT-23	DBV	5	250	Green (RoHS & no Sb/Br)	CU NIPDAU	Level-1-260C-UNLIM
TL431BIDBVTE4	ACTIVE	SOT-23	DBV	5	250	Green (RoHS & no Sb/Br)	CU NIPDAU	Level-1-260C-UNLIM
TL431BIDBZR	ACTIVE	SOT-23	DBZ	3	3000	Green (RoHS & no Sb/Br)	CU NIPDAU	Level-1-260C-UNLIM
TL431BIDBZRG4	ACTIVE	SOT-23	DBZ	3	3000	Green (RoHS & no Sb/Br)	CU NIPDAU	Level-1-260C-UNLIM
TL431BIDBZT	ACTIVE	SOT-23	DBZ	3	250	Green (RoHS & no Sb/Br)	CU NIPDAU	Level-1-260C-UNLIM
TL431BIDBZTG4	ACTIVE	SOT-23	DBZ	3	250	Green (RoHS & no Sb/Br)	CU NIPDAU	Level-1-260C-UNLIM
TL431BIDCKR	ACTIVE	SC70	DCK	6	3000	Green (RoHS & no Sb/Br)	CU NIPDAU	Level-1-260C-UNLIM
TL431BIDCKRE4	ACTIVE	SC70	DCK	6	3000	Green (RoHS & no Sb/Br)	CU NIPDAU	Level-1-260C-UNLIM
TL431BIDCKT	ACTIVE	SC70	DCK	6	250	Green (RoHS & no Sb/Br)	CU NIPDAU	Level-1-260C-UNLIM
TL431BIDCKTE4	ACTIVE	SC70	DCK	6	250	Green (RoHS & no Sb/Br)	CU NIPDAU	Level-1-260C-UNLIM
TL431BIDE4	ACTIVE	SOIC	D	8	75	Green (RoHS & no Sb/Br)	CU NIPDAU	Level-1-260C-UNLIM
TL431BIDR	ACTIVE	SOIC	D	8	2500	Green (RoHS & no Sb/Br)	CU NIPDAU	Level-1-260C-UNLIM
TL431BIDRE4	ACTIVE	SOIC	D	8	2500	Green (RoHS & no Sb/Br)	CU NIPDAU	Level-1-260C-UNLIM
TL431BILP	ACTIVE	TO-92	LP	3	1000	TBD	CU SNPB	Level-NC-NC-NC
TL431BILPR	ACTIVE	TO-92	LP	3	2000	TBD	CU SNPB	Level-NC-NC-NC
TL431BIP	ACTIVE	PDIP	P	8	50	Pb-Free	CU NIPDAU	Level-NC-NC-NC

Orderable Device	Status ⁽¹⁾	Package Type	Package Drawing	Pins	Package Qty	Eco Plan ⁽²⁾	Lead/Ball Finish	MSL Peak Temp ⁽³⁾
						(RoHS)		
TL431BIPE4	ACTIVE	PDIP	P	8	50	Pb-Free (RoHS)	CU NIPDAU	Level-NC-NC-NC
TL431BIPK	ACTIVE	SOT-89	PK	3	1000	TBD	CU SNPB	Level-1-220C-UNLIM
TL431BIPKG3	ACTIVE	SOT-89	PK	3	1000	Green (RoHS & no Sb/Br)	CU SN	Level-2-260C-1YEAR
TL431BQD	ACTIVE	SOIC	D	8	75	Green (RoHS & no Sb/Br)	CU NIPDAU	Level-1-260C-UNLIM
TL431BQDBVR	ACTIVE	SOT-23	DBV	5	3000	Green (RoHS & no Sb/Br)	CU NIPDAU	Level-1-260C-UNLIM
TL431BQDBVRE4	ACTIVE	SOT-23	DBV	5	3000	Green (RoHS & no Sb/Br)	CU NIPDAU	Level-1-260C-UNLIM
TL431BQDBVT	ACTIVE	SOT-23	DBV	5	250	Green (RoHS & no Sb/Br)	CU NIPDAU	Level-1-260C-UNLIM
TL431BQDBVTE4	ACTIVE	SOT-23	DBV	5	250	Green (RoHS & no Sb/Br)	CU NIPDAU	Level-1-260C-UNLIM
TL431BQDBZR	ACTIVE	SOT-23	DBZ	3	3000	Green (RoHS & no Sb/Br)	CU NIPDAU	Level-1-260C-UNLIM
TL431BQDBZRG4	ACTIVE	SOT-23	DBZ	3	3000	Green (RoHS & no Sb/Br)	CU NIPDAU	Level-1-260C-UNLIM
TL431BQDBZT	ACTIVE	SOT-23	DBZ	3	250	Green (RoHS & no Sb/Br)	CU NIPDAU	Level-1-260C-UNLIM
TL431BQDBZTG4	ACTIVE	SOT-23	DBZ	3	250	Green (RoHS & no Sb/Br)	CU NIPDAU	Level-1-260C-UNLIM
TL431BQDCKR	ACTIVE	SC70	DCK	6	3000	Green (RoHS & no Sb/Br)	CU NIPDAU	Level-1-260C-UNLIM
TL431BQDCKRE4	ACTIVE	SC70	DCK	6	3000	Green (RoHS & no Sb/Br)	CU NIPDAU	Level-1-260C-UNLIM
TL431BQDCKT	ACTIVE	SC70	DCK	6	250	Green (RoHS & no Sb/Br)	CU NIPDAU	Level-1-260C-UNLIM
TL431BQDCKTE4	ACTIVE	SC70	DCK	6	250	Green (RoHS & no Sb/Br)	CU NIPDAU	Level-1-260C-UNLIM
TL431BQDE4	ACTIVE	SOIC	D	8	75	Green (RoHS & no Sb/Br)	CU NIPDAU	Level-1-260C-UNLIM
TL431BQDR	ACTIVE	SOIC	D	8	2500	Green (RoHS & no Sb/Br)	CU NIPDAU	Level-1-260C-UNLIM
TL431BQDRE4	ACTIVE	SOIC	D	8	2500	Green (RoHS & no Sb/Br)	CU NIPDAU	Level-1-260C-UNLIM
TL431BQLP	ACTIVE	TO-92	LP	3	1000	TBD	CU SNPB	Level-NC-NC-NC
TL431BQLPM	ACTIVE	TO-92	LP	3	2000	TBD	CU SNPB	Level-NC-NC-NC
TL431BQLPR	ACTIVE	TO-92	LP	3	2000	TBD	CU SNPB	Level-NC-NC-NC
TL431BQPK	ACTIVE	SOT-89	PK	3	1000	TBD	CU SNPB	Level-1-220C-UNLIM
TL431BQPKG3	ACTIVE	SOT-89	PK	3	1000	Green (RoHS & no Sb/Br)	CU SN	Level-2-260C-1YEAR
TL431BQPSR	PREVIEW	SO	PS	8	2000	TBD	Call TI	Call TI
TL431CD	ACTIVE	SOIC	D	8	75	Green (RoHS & no Sb/Br)	CU NIPDAU	Level-1-260C-UNLIM
TL431CDBVR	ACTIVE	SOT-23	DBV	5	3000	Green (RoHS & no Sb/Br)	CU NIPDAU	Level-1-260C-UNLIM
TL431CDBVT	ACTIVE	SOT-23	DBV	5	250	Green (RoHS & no Sb/Br)	CU NIPDAU	Level-1-260C-UNLIM

Orderable Device	Status ⁽¹⁾	Package Type	Package Drawing	Pins	Package Qty	Eco Plan ⁽²⁾	Lead/Ball Finish	MSL Peak Temp ⁽³⁾
						no Sb/Br)		
TL431CDBZR	ACTIVE	SOT-23	DBZ	3	3000	Green (RoHS & no Sb/Br)	CU NIPDAU	Level-1-260C-UNLIM
TL431CDBZRG4	ACTIVE	SOT-23	DBZ	3	3000	Green (RoHS & no Sb/Br)	CU NIPDAU	Level-1-260C-UNLIM
TL431CDBZT	ACTIVE	SOT-23	DBZ	3	250	Green (RoHS & no Sb/Br)	CU NIPDAU	Level-1-260C-UNLIM
TL431CDBZTG4	ACTIVE	SOT-23	DBZ	3	250	Green (RoHS & no Sb/Br)	CU NIPDAU	Level-1-260C-UNLIM
TL431CDG4	ACTIVE	SOIC	D	8	75	Green (RoHS & no Sb/Br)	CU NIPDAU	Level-1-260C-UNLIM
TL431CDR	ACTIVE	SOIC	D	8	2500	Green (RoHS & no Sb/Br)	CU NIPDAU	Level-1-260C-UNLIM
TL431CDRG4	ACTIVE	SOIC	D	8	2500	Green (RoHS & no Sb/Br)	CU NIPDAU	Level-1-260C-UNLIM
TL431CKTPR	OBSOLETE	PFM	KTP	2		TBD	Call TI	Call TI
TL431CLP	ACTIVE	TO-92	LP	3	1000	TBD	CU SNPB	Level-NC-NC-NC
TL431CLPB-TDJ	OBSOLETE	TO-92	LP	3		TBD	Call TI	Call TI
TL431CLPM	ACTIVE	TO-92	LP	3	2000	TBD	CU SNPB	Level-NC-NC-NC
TL431CLPR	ACTIVE	TO-92	LP	3	2000	TBD	CU SNPB	Level-NC-NC-NC
TL431CP	ACTIVE	PDIP	P	8	50	Pb-Free (RoHS)	CU NIPDAU	Level-NC-NC-NC
TL431CPK	ACTIVE	SOT-89	PK	3	1000	TBD	CU SNPB	Level-1-220C-UNLIM
TL431CPSLE	OBSOLETE	SO	PS	8		TBD	Call TI	Call TI
TL431CPSR	ACTIVE	SO	PS	8	2000	Green (RoHS & no Sb/Br)	CU NIPDAU	Level-1-260C-UNLIM
TL431CPSRG4	ACTIVE	SO	PS	8	2000	Green (RoHS & no Sb/Br)	CU NIPDAU	Level-1-260C-UNLIM
TL431CPW	ACTIVE	TSSOP	PW	8	150	Green (RoHS & no Sb/Br)	CU NIPDAU	Level-1-260C-UNLIM
TL431CPWE4	ACTIVE	TSSOP	PW	8	150	Green (RoHS & no Sb/Br)	CU NIPDAU	Level-1-260C-UNLIM
TL431CPWLE	OBSOLETE	TSSOP	PW	8		TBD	Call TI	Call TI
TL431CPWR	ACTIVE	TSSOP	PW	8	2000	Green (RoHS & no Sb/Br)	CU NIPDAU	Level-1-260C-UNLIM
TL431CPWRE4	ACTIVE	TSSOP	PW	8	2000	Green (RoHS & no Sb/Br)	CU NIPDAU	Level-1-260C-UNLIM
TL431ID	ACTIVE	SOIC	D	8	75	Green (RoHS & no Sb/Br)	CU NIPDAU	Level-1-260C-UNLIM
TL431IDBVR	ACTIVE	SOT-23	DBV	5	3000	Green (RoHS & no Sb/Br)	CU NIPDAU	Level-1-260C-UNLIM
TL431IDBVRE4	ACTIVE	SOT-23	DBV	5	3000	Green (RoHS & no Sb/Br)	CU NIPDAU	Level-1-260C-UNLIM
TL431IDBVT	ACTIVE	SOT-23	DBV	5	250	Green (RoHS & no Sb/Br)	CU NIPDAU	Level-1-260C-UNLIM
TL431IDBZR	ACTIVE	SOT-23	DBZ	3	3000	Green (RoHS & no Sb/Br)	CU NIPDAU	Level-1-260C-UNLIM
TL431IDBZRG4	ACTIVE	SOT-23	DBZ	3	3000	Green (RoHS & no Sb/Br)	CU NIPDAU	Level-1-260C-UNLIM
TL431IDBZT	ACTIVE	SOT-23	DBZ	3	250	Green (RoHS & no Sb/Br)	CU NIPDAU	Level-1-260C-UNLIM

Orderable Device	Status ⁽¹⁾	Package Type	Package Drawing	Pins	Package Qty	Eco Plan ⁽²⁾	Lead/Ball Finish	MSL Peak Temp ⁽³⁾
						no Sb/Br)		
TL431IDBZTG4	ACTIVE	SOT-23	DBZ	3	250	Green (RoHS & no Sb/Br)	CU NIPDAU	Level-1-260C-UNLIM
TL431IDG4	ACTIVE	SOIC	D	8	75	Green (RoHS & no Sb/Br)	CU NIPDAU	Level-1-260C-UNLIM
TL431IDR	ACTIVE	SOIC	D	8	2500	Green (RoHS & no Sb/Br)	CU NIPDAU	Level-1-260C-UNLIM
TL431IDRG4	ACTIVE	SOIC	D	8	2500	Green (RoHS & no Sb/Br)	CU NIPDAU	Level-1-260C-UNLIM
TL431ILP	ACTIVE	TO-92	LP	3	1000	TBD	CU SNPB	Level-NC-NC-NC
TL431ILPM	OBSOLETE	TO-92	LP	3		TBD	Call TI	Call TI
TL431ILPR	ACTIVE	TO-92	LP	3	2000	TBD	CU SNPB	Level-NC-NC-NC
TL431IP	ACTIVE	PDIP	P	8	50	Pb-Free (RoHS)	CU NIPDAU	Level-NC-NC-NC
TL431IPK	ACTIVE	SOT-89	PK	3	1000	TBD	CU SNPB	Level-1-220C-UNLIM
TL431MFKB	OBSOLETE	LCCC	FK	20		TBD	Call TI	Call TI
TL431MJG	OBSOLETE	CDIP	JG	8		TBD	Call TI	Call TI
TL431MJGB	OBSOLETE	CDIP	JG	8		TBD	Call TI	Call TI
TL431QDBVR	ACTIVE	SOT-23	DBV	5	3000	Green (RoHS & no Sb/Br)	CU NIPDAU	Level-1-260C-UNLIM
TL431QDBVRE4	ACTIVE	SOT-23	DBV	5	3000	Green (RoHS & no Sb/Br)	CU NIPDAU	Level-1-260C-UNLIM
TL431QDBVT	ACTIVE	SOT-23	DBV	5	250	Green (RoHS & no Sb/Br)	CU NIPDAU	Level-1-260C-UNLIM
TL431QDBVTE4	ACTIVE	SOT-23	DBV	5	250	Green (RoHS & no Sb/Br)	CU NIPDAU	Level-1-260C-UNLIM
TL431QDBZR	ACTIVE	SOT-23	DBZ	3	3000	Green (RoHS & no Sb/Br)	CU NIPDAU	Level-1-260C-UNLIM
TL431QDBZRG4	ACTIVE	SOT-23	DBZ	3	3000	Green (RoHS & no Sb/Br)	CU NIPDAU	Level-1-260C-UNLIM
TL431QDBZT	ACTIVE	SOT-23	DBZ	3	250	Green (RoHS & no Sb/Br)	CU NIPDAU	Level-1-260C-UNLIM
TL431QDBZTG4	ACTIVE	SOT-23	DBZ	3	250	Green (RoHS & no Sb/Br)	CU NIPDAU	Level-1-260C-UNLIM
TL431QDCKR	ACTIVE	SC70	DCK	6	3000	Green (RoHS & no Sb/Br)	CU NIPDAU	Level-1-260C-UNLIM
TL431QDCKRE4	ACTIVE	SC70	DCK	6	3000	Green (RoHS & no Sb/Br)	CU NIPDAU	Level-1-260C-UNLIM
TL431QDCKT	ACTIVE	SC70	DCK	6	250	Green (RoHS & no Sb/Br)	CU NIPDAU	Level-1-260C-UNLIM
TL431QDCKTE4	ACTIVE	SC70	DCK	6	250	Green (RoHS & no Sb/Br)	CU NIPDAU	Level-1-260C-UNLIM
TL431QPK	ACTIVE	SOT-89	PK	3	1000	TBD	CU SNPB	Level-1-220C-UNLIM
TL431QPKG3	ACTIVE	SOT-89	PK	3	1000	Green (RoHS & no Sb/Br)	CU SN	Level-2-260C-1YEAR
TL432ACDBVR	ACTIVE	SOT-23	DBV	5	3000	Green (RoHS & no Sb/Br)	CU NIPDAU	Level-1-260C-UNLIM
TL432ACDBVRE4	ACTIVE	SOT-23	DBV	5	3000	Green (RoHS & no Sb/Br)	CU NIPDAU	Level-1-260C-UNLIM
TL432ACDBZR	ACTIVE	SOT-23	DBZ	3	3000	Green (RoHS & no Sb/Br)	CU NIPDAU	Level-1-260C-UNLIM

Orderable Device	Status ⁽¹⁾	Package Type	Package Drawing	Pins	Package Qty	Eco Plan ⁽²⁾	Lead/Ball Finish	MSL Peak Temp ⁽³⁾
						no Sb/Br)		
TL432ACDBZRG4	ACTIVE	SOT-23	DBZ	3	3000	Green (RoHS & no Sb/Br)	CU NIPDAU	Level-1-260C-UNLIM
TL432ACDBZT	ACTIVE	SOT-23	DBZ	3	250	Green (RoHS & no Sb/Br)	CU NIPDAU	Level-1-260C-UNLIM
TL432ACDBZTG4	ACTIVE	SOT-23	DBZ	3	250	Green (RoHS & no Sb/Br)	CU NIPDAU	Level-1-260C-UNLIM
TL432ACPK	ACTIVE	SOT-89	PK	3	1000	TBD	CU SNPB	Level-1-220C-UNLIM
TL432ACPKG3	ACTIVE	SOT-89	PK	3	1000	Green (RoHS & no Sb/Br)	CU SN	Level-2-260C-1YEAR
TL432AIDBVR	ACTIVE	SOT-23	DBV	5	3000	Green (RoHS & no Sb/Br)	CU NIPDAU	Level-1-260C-UNLIM
TL432AIDBVRE4	ACTIVE	SOT-23	DBV	5	3000	Green (RoHS & no Sb/Br)	CU NIPDAU	Level-1-260C-UNLIM
TL432AIDBZR	ACTIVE	SOT-23	DBZ	3	3000	Green (RoHS & no Sb/Br)	CU NIPDAU	Level-1-260C-UNLIM
TL432AIDBZRG4	ACTIVE	SOT-23	DBZ	3	3000	Green (RoHS & no Sb/Br)	CU NIPDAU	Level-1-260C-UNLIM
TL432AIDBZT	ACTIVE	SOT-23	DBZ	3	250	Green (RoHS & no Sb/Br)	CU NIPDAU	Level-1-260C-UNLIM
TL432AIDBZTG4	ACTIVE	SOT-23	DBZ	3	250	Green (RoHS & no Sb/Br)	CU NIPDAU	Level-1-260C-UNLIM
TL432AIPK	ACTIVE	SOT-89	PK	3	1000	TBD	CU SNPB	Level-1-220C-UNLIM
TL432AIPKG3	ACTIVE	SOT-89	PK	3	1000	Green (RoHS & no Sb/Br)	CU SN	Level-2-260C-1YEAR
TL432AQDBVR	ACTIVE	SOT-23	DBV	5	3000	Green (RoHS & no Sb/Br)	CU NIPDAU	Level-1-260C-UNLIM
TL432AQDBVRE4	ACTIVE	SOT-23	DBV	5	3000	Green (RoHS & no Sb/Br)	CU NIPDAU	Level-1-260C-UNLIM
TL432AQDBVT	ACTIVE	SOT-23	DBV	5	250	Green (RoHS & no Sb/Br)	CU NIPDAU	Level-1-260C-UNLIM
TL432AQDBVTE4	ACTIVE	SOT-23	DBV	5	250	Green (RoHS & no Sb/Br)	CU NIPDAU	Level-1-260C-UNLIM
TL432AQDBZR	ACTIVE	SOT-23	DBZ	3	3000	Green (RoHS & no Sb/Br)	CU NIPDAU	Level-1-260C-UNLIM
TL432AQDBZRG4	ACTIVE	SOT-23	DBZ	3	3000	Green (RoHS & no Sb/Br)	CU NIPDAU	Level-1-260C-UNLIM
TL432AQDBZT	ACTIVE	SOT-23	DBZ	3	250	Green (RoHS & no Sb/Br)	CU NIPDAU	Level-1-260C-UNLIM
TL432AQDBZTG4	ACTIVE	SOT-23	DBZ	3	250	Green (RoHS & no Sb/Br)	CU NIPDAU	Level-1-260C-UNLIM
TL432AQPK	ACTIVE	SOT-89	PK	3	1000	TBD	CU SNPB	Level-1-220C-UNLIM
TL432AQPKG3	ACTIVE	SOT-89	PK	3	1000	Green (RoHS & no Sb/Br)	CU SN	Level-2-260C-1YEAR
TL432BCDBVR	ACTIVE	SOT-23	DBV	5	3000	Green (RoHS & no Sb/Br)	CU NIPDAU	Level-1-260C-UNLIM
TL432BCDBVRE4	ACTIVE	SOT-23	DBV	5	3000	Green (RoHS & no Sb/Br)	CU NIPDAU	Level-1-260C-UNLIM
TL432BCDBZR	ACTIVE	SOT-23	DBZ	3	3000	Green (RoHS & no Sb/Br)	CU NIPDAU	Level-1-260C-UNLIM
TL432BCDBZRG4	ACTIVE	SOT-23	DBZ	3	3000	Green (RoHS & no Sb/Br)	CU NIPDAU	Level-1-260C-UNLIM

Orderable Device	Status ⁽¹⁾	Package Type	Package Drawing	Pins	Package Qty	Eco Plan ⁽²⁾	Lead/Ball Finish	MSL Peak Temp ⁽³⁾
						no Sb/Br)		
TL432BCDBZT	ACTIVE	SOT-23	DBZ	3	250	Green (RoHS & no Sb/Br)	CU NIPDAU	Level-1-260C-UNLIM
TL432BCDBZTG4	ACTIVE	SOT-23	DBZ	3	250	Green (RoHS & no Sb/Br)	CU NIPDAU	Level-1-260C-UNLIM
TL432BCPK	ACTIVE	SOT-89	PK	3	1000	TBD	CU SNPB	Level-1-220C-UNLIM
TL432BCPKG3	ACTIVE	SOT-89	PK	3	1000	Green (RoHS & no Sb/Br)	CU SN	Level-2-260C-1YEAR
TL432BIDBVR	ACTIVE	SOT-23	DBV	5	3000	Green (RoHS & no Sb/Br)	CU NIPDAU	Level-1-260C-UNLIM
TL432BIDBVRE4	ACTIVE	SOT-23	DBV	5	3000	Green (RoHS & no Sb/Br)	CU NIPDAU	Level-1-260C-UNLIM
TL432BIDBZR	ACTIVE	SOT-23	DBZ	3	3000	Green (RoHS & no Sb/Br)	CU NIPDAU	Level-1-260C-UNLIM
TL432BIDBZRG4	ACTIVE	SOT-23	DBZ	3	3000	Green (RoHS & no Sb/Br)	CU NIPDAU	Level-1-260C-UNLIM
TL432BIDBZT	ACTIVE	SOT-23	DBZ	3	250	Green (RoHS & no Sb/Br)	CU NIPDAU	Level-1-260C-UNLIM
TL432BIDBZTG4	ACTIVE	SOT-23	DBZ	3	250	Green (RoHS & no Sb/Br)	CU NIPDAU	Level-1-260C-UNLIM
TL432BIPK	ACTIVE	SOT-89	PK	3	1000	TBD	CU SNPB	Level-1-220C-UNLIM
TL432BIPKG3	ACTIVE	SOT-89	PK	3	1000	Green (RoHS & no Sb/Br)	CU SN	Level-2-260C-1YEAR
TL432BQDBVR	ACTIVE	SOT-23	DBV	5	3000	Green (RoHS & no Sb/Br)	CU NIPDAU	Level-1-260C-UNLIM
TL432BQDBVRE4	ACTIVE	SOT-23	DBV	5	3000	Green (RoHS & no Sb/Br)	CU NIPDAU	Level-1-260C-UNLIM
TL432BQDBVT	ACTIVE	SOT-23	DBV	5	250	Green (RoHS & no Sb/Br)	CU NIPDAU	Level-1-260C-UNLIM
TL432BQDBVTE4	ACTIVE	SOT-23	DBV	5	250	Green (RoHS & no Sb/Br)	CU NIPDAU	Level-1-260C-UNLIM
TL432BQDBZR	ACTIVE	SOT-23	DBZ	3	3000	Green (RoHS & no Sb/Br)	CU NIPDAU	Level-1-260C-UNLIM
TL432BQDBZRG4	ACTIVE	SOT-23	DBZ	3	3000	Green (RoHS & no Sb/Br)	CU NIPDAU	Level-1-260C-UNLIM
TL432BQDBZT	PREVIEW	SOT-23	DBZ	3	250	TBD	Call TI	Call TI
TL432BQPK	ACTIVE	SOT-89	PK	3	1000	TBD	CU SNPB	Level-1-220C-UNLIM
TL432BQPKG3	ACTIVE	SOT-89	PK	3	1000	Green (RoHS & no Sb/Br)	CU SN	Level-2-260C-1YEAR
TL432CDBVR	ACTIVE	SOT-23	DBV	5	3000	Green (RoHS & no Sb/Br)	CU NIPDAU	Level-1-260C-UNLIM
TL432CDBVRE4	ACTIVE	SOT-23	DBV	5	3000	Green (RoHS & no Sb/Br)	CU NIPDAU	Level-1-260C-UNLIM
TL432CDBZR	ACTIVE	SOT-23	DBZ	3	3000	Green (RoHS & no Sb/Br)	CU NIPDAU	Level-1-260C-UNLIM
TL432CDBZRG4	ACTIVE	SOT-23	DBZ	3	3000	Green (RoHS & no Sb/Br)	CU NIPDAU	Level-1-260C-UNLIM
TL432CDBZT	ACTIVE	SOT-23	DBZ	3	250	Green (RoHS & no Sb/Br)	CU NIPDAU	Level-1-260C-UNLIM
TL432CDBZTG4	ACTIVE	SOT-23	DBZ	3	250	Green (RoHS & no Sb/Br)	CU NIPDAU	Level-1-260C-UNLIM

Orderable Device	Status ⁽¹⁾	Package Type	Package Drawing	Pins	Package Qty	Eco Plan ⁽²⁾	Lead/Ball Finish	MSL Peak Temp ⁽³⁾
TL432CPK	ACTIVE	SOT-89	PK	3	1000	TBD	CU SNPB	Level-1-220C-UNLIM
TL432CPKG3	ACTIVE	SOT-89	PK	3	1000	Green (RoHS & no Sb/Br)	CU SN	Level-2-260C-1YEAR
TL432IDBVR	ACTIVE	SOT-23	DBV	5	3000	Green (RoHS & no Sb/Br)	CU NIPDAU	Level-1-260C-UNLIM
TL432IDBVRE4	ACTIVE	SOT-23	DBV	5	3000	Green (RoHS & no Sb/Br)	CU NIPDAU	Level-1-260C-UNLIM
TL432IDBZR	ACTIVE	SOT-23	DBZ	3	3000	Green (RoHS & no Sb/Br)	CU NIPDAU	Level-1-260C-UNLIM
TL432IDBZRG4	ACTIVE	SOT-23	DBZ	3	3000	Green (RoHS & no Sb/Br)	CU NIPDAU	Level-1-260C-UNLIM
TL432IDBZT	ACTIVE	SOT-23	DBZ	3	250	Green (RoHS & no Sb/Br)	CU NIPDAU	Level-1-260C-UNLIM
TL432IDBZTG4	ACTIVE	SOT-23	DBZ	3	250	Green (RoHS & no Sb/Br)	CU NIPDAU	Level-1-260C-UNLIM
TL432IPK	ACTIVE	SOT-89	PK	3	1000	TBD	CU SNPB	Level-1-220C-UNLIM
TL432IPKG3	ACTIVE	SOT-89	PK	3	1000	Green (RoHS & no Sb/Br)	CU SN	Level-2-260C-1YEAR
TL432QDBVR	ACTIVE	SOT-23	DBV	5	3000	Green (RoHS & no Sb/Br)	CU NIPDAU	Level-1-260C-UNLIM
TL432QDBVRE4	ACTIVE	SOT-23	DBV	5	3000	Green (RoHS & no Sb/Br)	CU NIPDAU	Level-1-260C-UNLIM
TL432QDBVT	ACTIVE	SOT-23	DBV	5	250	Green (RoHS & no Sb/Br)	CU NIPDAU	Level-1-260C-UNLIM
TL432QDBVTE4	ACTIVE	SOT-23	DBV	5	250	Green (RoHS & no Sb/Br)	CU NIPDAU	Level-1-260C-UNLIM
TL432QDBZR	ACTIVE	SOT-23	DBZ	3	3000	Green (RoHS & no Sb/Br)	CU NIPDAU	Level-1-260C-UNLIM
TL432QDBZRG4	ACTIVE	SOT-23	DBZ	3	3000	Green (RoHS & no Sb/Br)	CU NIPDAU	Level-1-260C-UNLIM
TL432QDBZT	ACTIVE	SOT-23	DBZ	3	250	Green (RoHS & no Sb/Br)	CU NIPDAU	Level-1-260C-UNLIM
TL432QDBZTG4	ACTIVE	SOT-23	DBZ	3	250	Green (RoHS & no Sb/Br)	CU NIPDAU	Level-1-260C-UNLIM
TL432QPK	ACTIVE	SOT-89	PK	3	1000	TBD	CU SNPB	Level-1-220C-UNLIM
TL432QPKG3	ACTIVE	SOT-89	PK	3	1000	Green (RoHS & no Sb/Br)	CU SN	Level-2-260C-1YEAR

⁽¹⁾ The marketing status values are defined as follows:

ACTIVE: Product device recommended for new designs.

LIFEBUY: TI has announced that the device will be discontinued, and a lifetime-buy period is in effect.

NRND: Not recommended for new designs. Device is in production to support existing customers, but TI does not recommend using this part in a new design.

PREVIEW: Device has been announced but is not in production. Samples may or may not be available.

OBSELETE: TI has discontinued the production of the device.

⁽²⁾ Eco Plan - The planned eco-friendly classification: Pb-Free (RoHS) or Green (RoHS & no Sb/Br) - please check <http://www.ti.com/productcontent> for the latest availability information and additional product content details.

TBD: The Pb-Free/Green conversion plan has not been defined.

Pb-Free (RoHS): TI's terms "Lead-Free" or "Pb-Free" mean semiconductor products that are compatible with the current RoHS requirements for all 6 substances, including the requirement that lead not exceed 0.1% by weight in homogeneous materials. Where designed to be soldered at high temperatures, TI Pb-Free products are suitable for use in specified lead-free processes.

Green (RoHS & no Sb/Br): TI defines "Green" to mean Pb-Free (RoHS compatible), and free of Bromine (Br) and Antimony (Sb) based flame retardants (Br or Sb do not exceed 0.1% by weight in homogeneous material)

⁽³⁾ MSL, Peak Temp. -- The Moisture Sensitivity Level rating according to the JEDEC industry standard classifications, and peak solder temperature.

Important Information and Disclaimer:The information provided on this page represents TI's knowledge and belief as of the date that it is provided. TI bases its knowledge and belief on information provided by third parties, and makes no representation or warranty as to the accuracy of such information. Efforts are underway to better integrate information from third parties. TI has taken and continues to take reasonable steps to provide representative and accurate information but may not have conducted destructive testing or chemical analysis on incoming materials and chemicals. TI and TI suppliers consider certain information to be proprietary, and thus CAS numbers and other limited information may not be available for release.

In no event shall TI's liability arising out of such information exceed the total purchase price of the TI part(s) at issue in this document sold by TI to Customer on an annual basis.

JG (R-GDIP-T8)

CERAMIC DUAL-IN-LINE

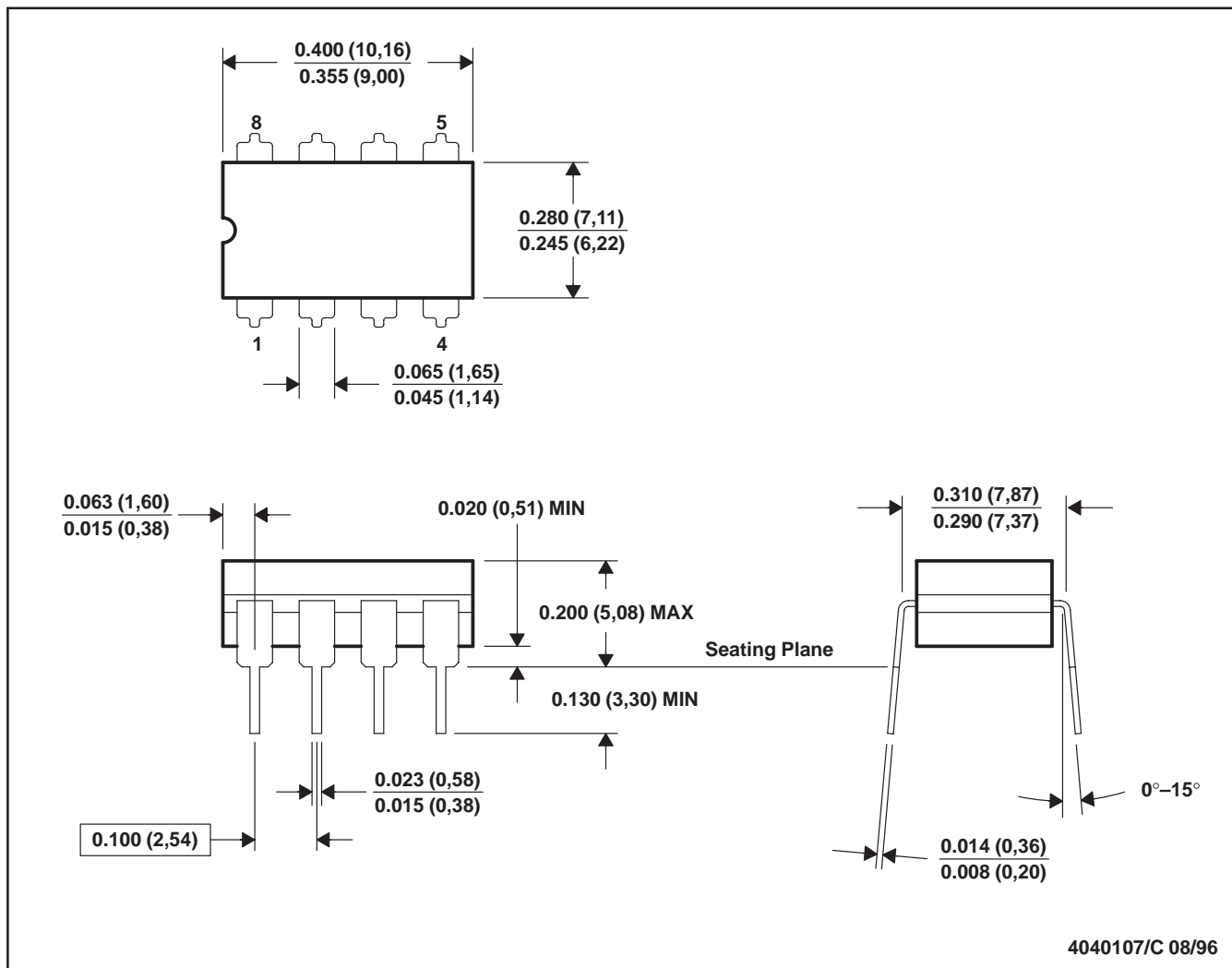

- NOTES: A. All linear dimensions are in inches (millimeters).
 B. This drawing is subject to change without notice.
 C. This package can be hermetically sealed with a ceramic lid using glass frit.
 D. Index point is provided on cap for terminal identification.
 E. Falls within MIL STD 1835 GDIP1-T8

PK (R-PSSO-F3)

PLASTIC SINGLE-IN-LINE PACKAGE

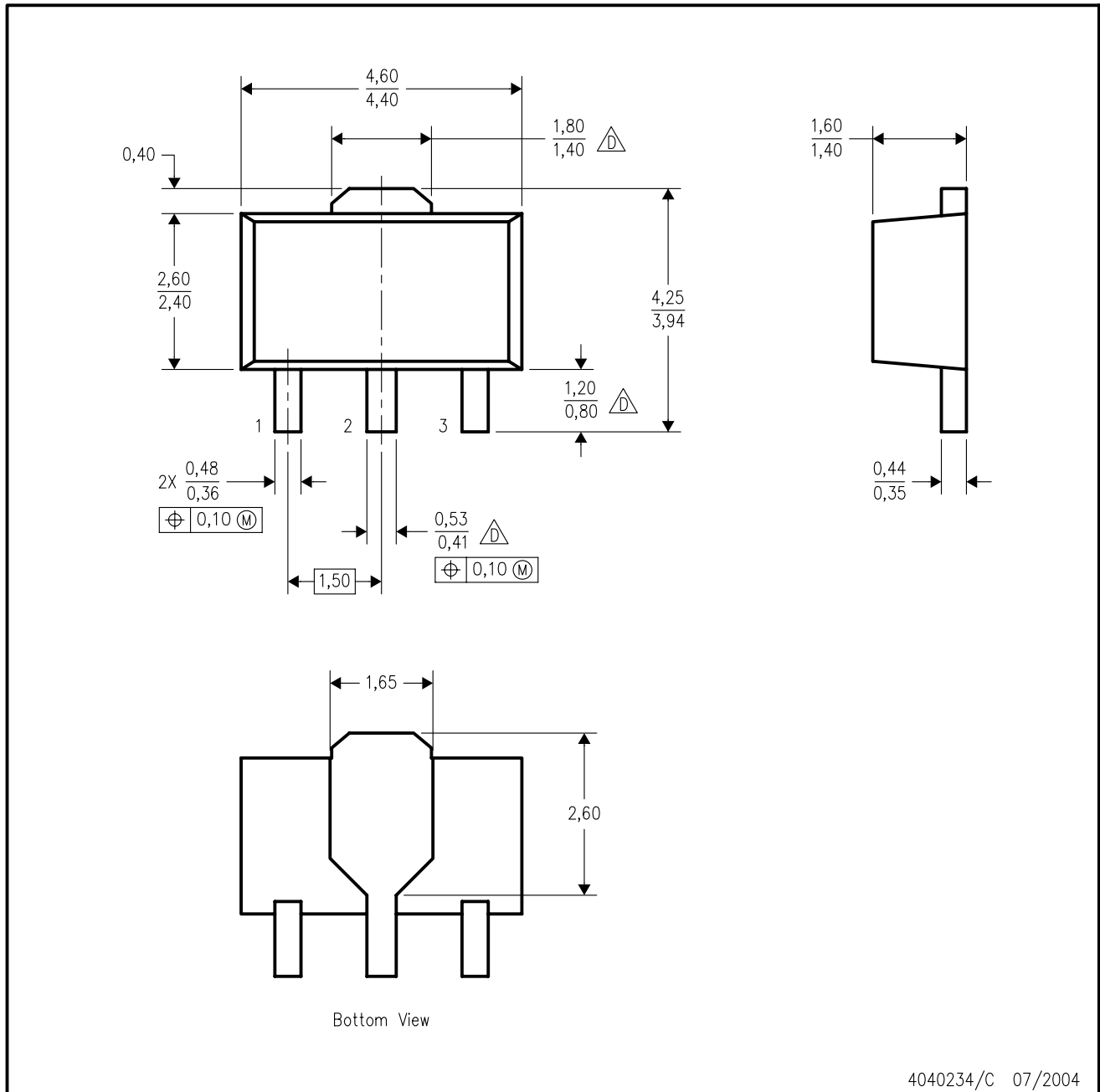

- NOTES:
- A. All linear dimensions are in millimeters. Dimensioning and tolerancing per ASME Y14.5-1994.
 - B. This drawing is subject to change without notice.
 - C. The center lead is in electrical contact with the tab.
-  Falls within JEDEC TO-243 variation AA, except minimum lead length, pin 2 minimum lead width, and minimum tab width.

FK (S-CQCC-N**)

LEADLESS CERAMIC CHIP CARRIER

28 TERMINAL SHOWN

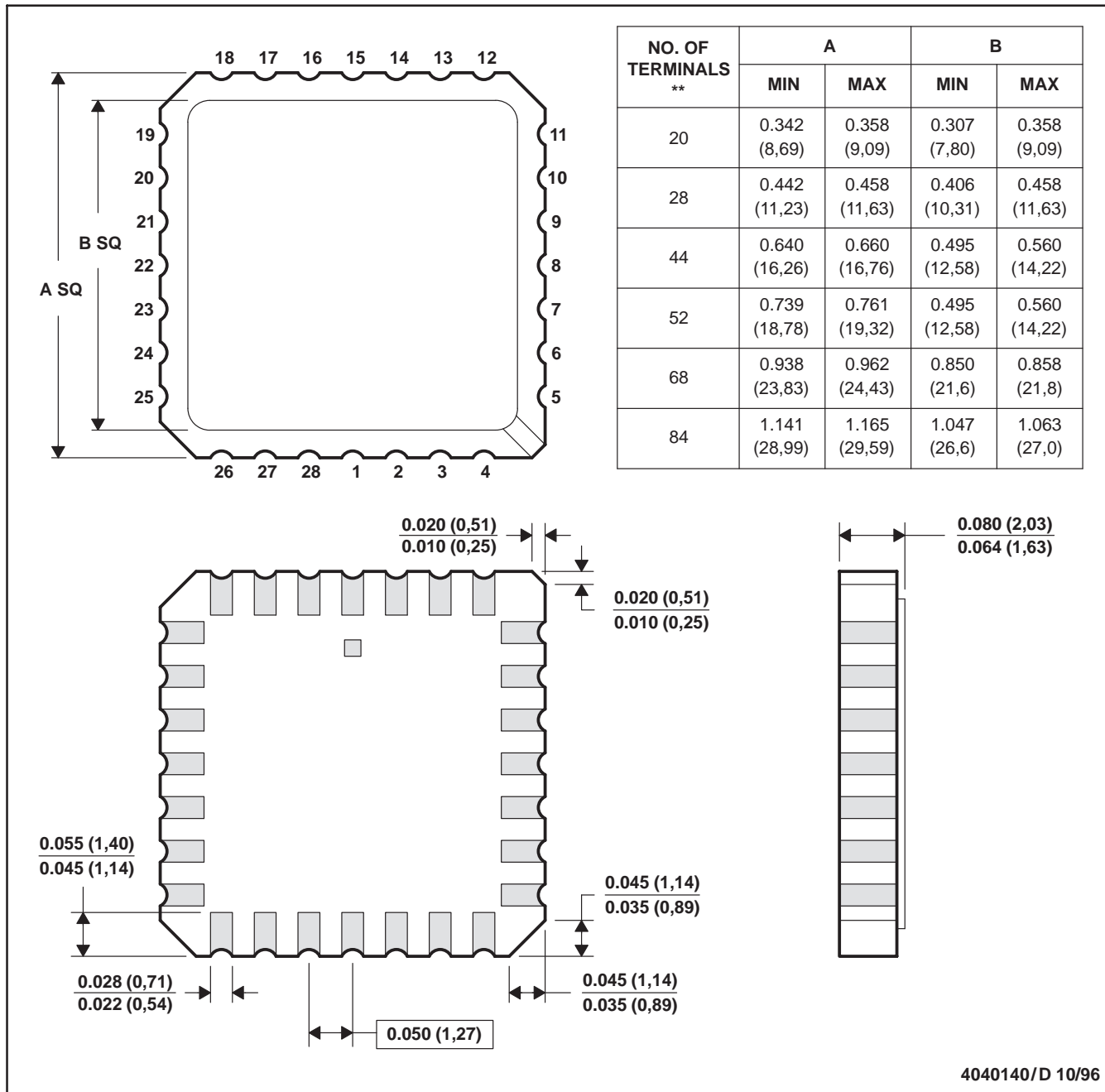

- NOTES:
- A. All linear dimensions are in inches (millimeters).
 - B. This drawing is subject to change without notice.
 - C. This package can be hermetically sealed with a metal lid.
 - D. The terminals are gold plated.
 - E. Falls within JEDEC MS-004

P (R-PDIP-T8)

PLASTIC DUAL-IN-LINE

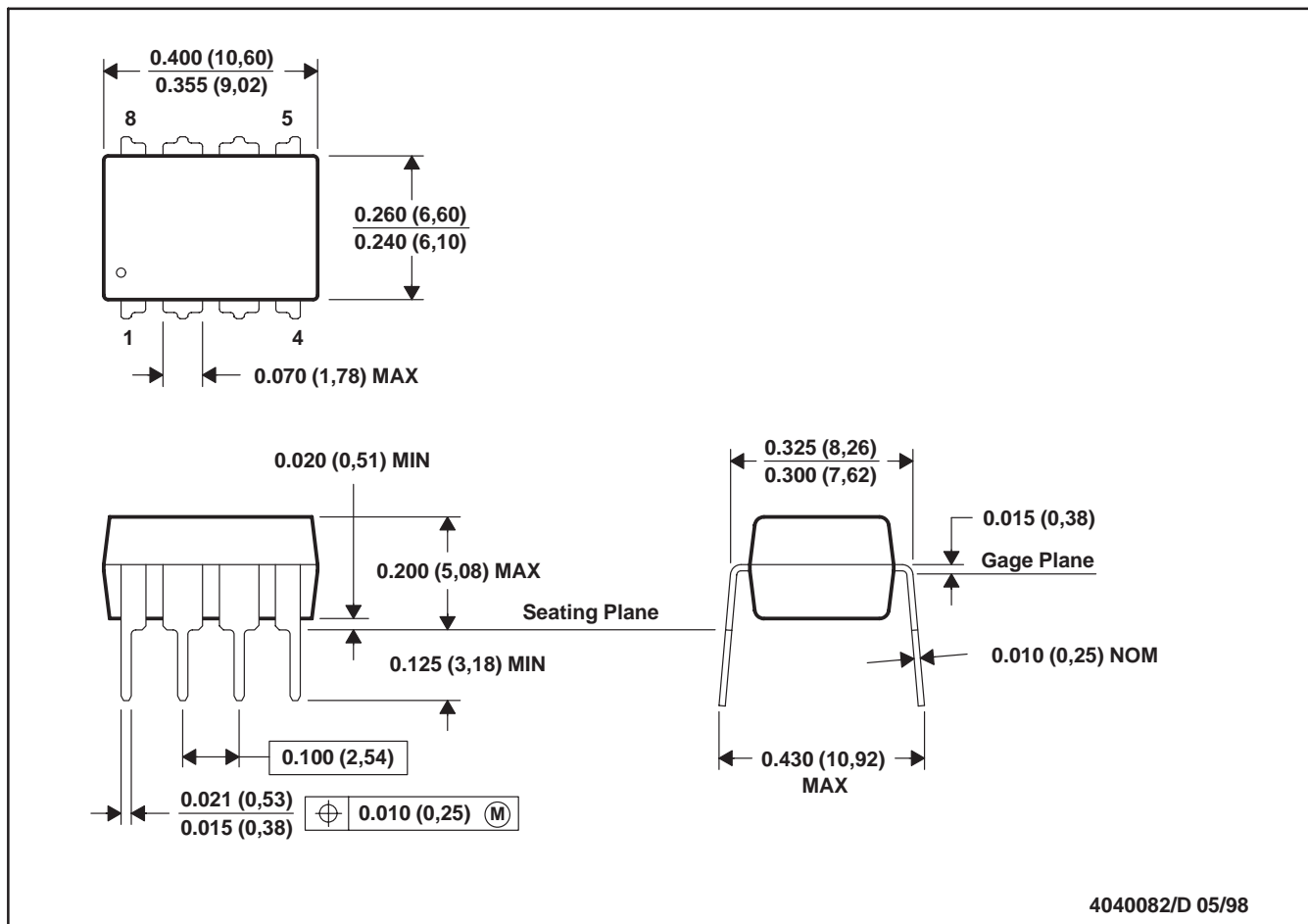

- NOTES: A. All linear dimensions are in inches (millimeters).
 B. This drawing is subject to change without notice.
 C. Falls within JEDEC MS-001

For the latest package information, go to http://www.ti.com/sc/docs/package/pkg_info.htm

DBZ (R-PDSO-G3)

PLASTIC SMALL-OUTLINE

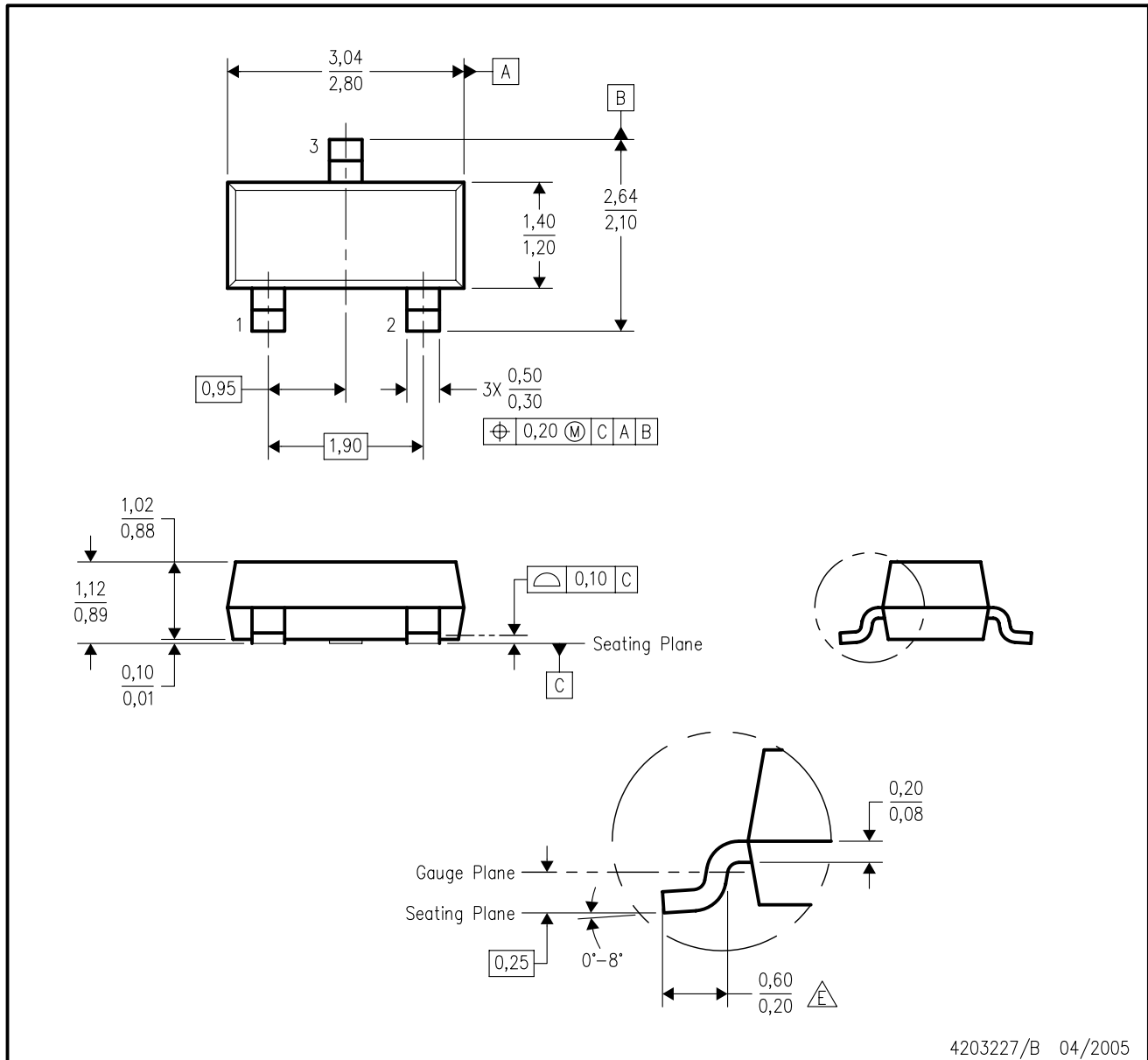

NOTES: A. All linear dimensions are in millimeters. Dimensioning and tolerancing per ASME Y14.5M-1994.
 B. This drawing is subject to change without notice.
 C. Lead dimensions are inclusive of plating.
 D. Body dimensions are exclusive of mold flash and protrusion. Mold flash and protrusion not to exceed 0.25 per side.
 (E) Falls within JEDEC TO-236 variation AB, except minimum foot length.

DCK (R-PDSO-G6)

PLASTIC SMALL-OUTLINE PACKAGE

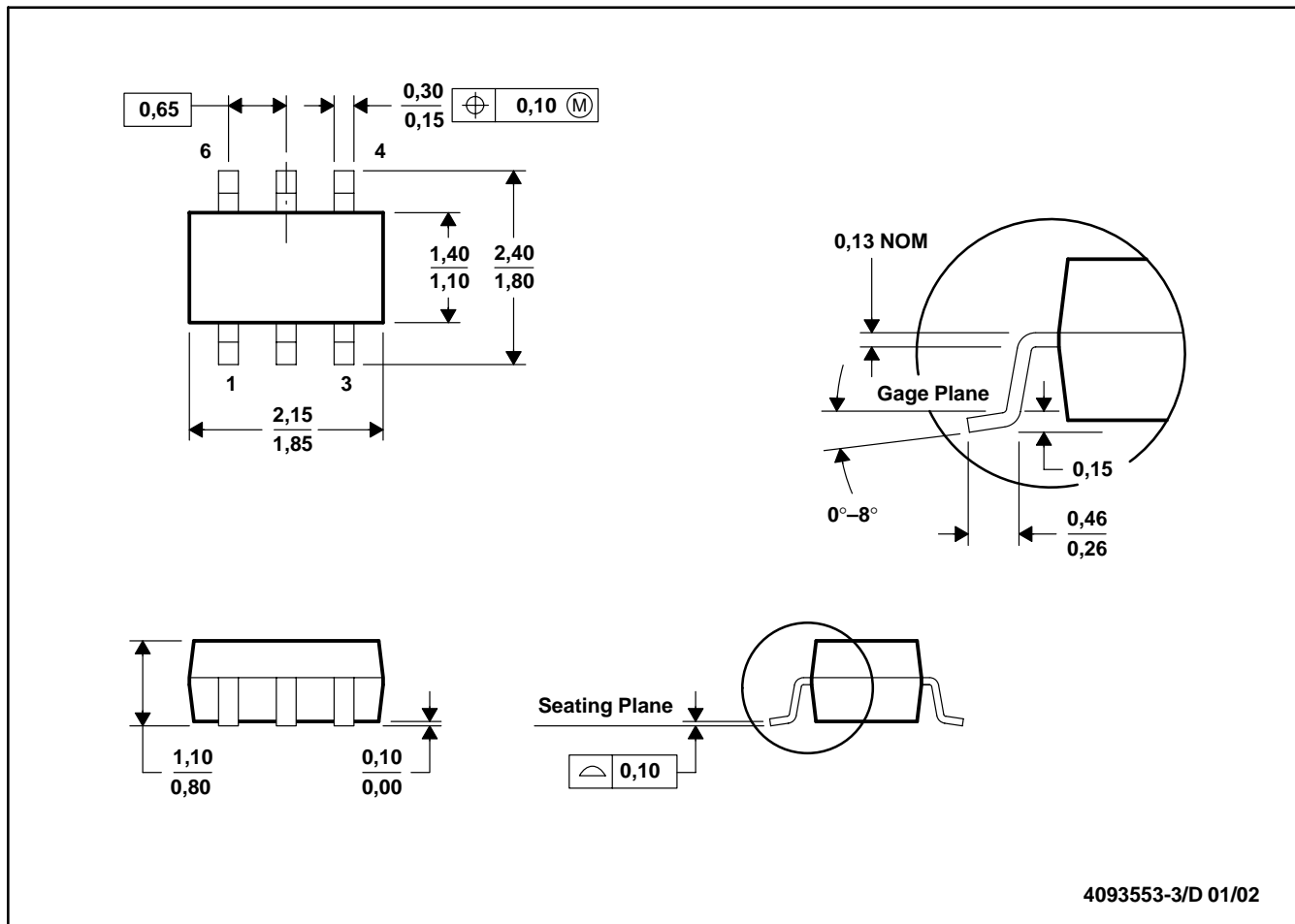

4093553-3/D 01/02

- NOTES:
- A. All linear dimensions are in millimeters.
 - B. This drawing is subject to change without notice.
 - C. Body dimensions do not include mold flash or protrusion.
 - D. Falls within JEDEC MO-203

KTP (R-PSFM-G2)

PowerFLEX™ PLASTIC FLANGE-MOUNT PACKAGE

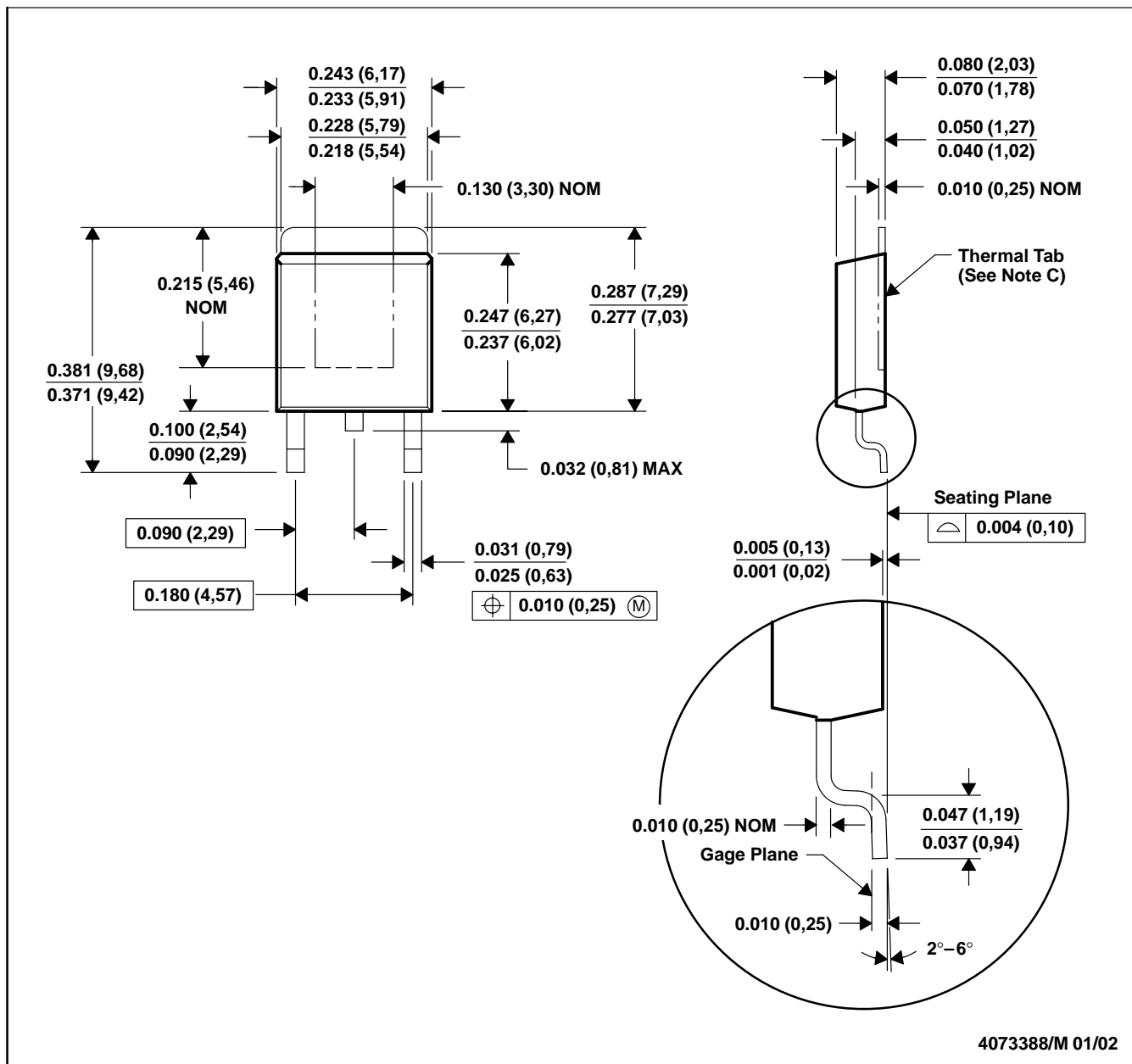

- NOTES: A. All linear dimensions are in inches (millimeters).
 B. This drawing is subject to change without notice.
 C. The center lead is in electrical contact with the thermal tab.
 D. Dimensions do not include mold protrusions, not to exceed 0.006 (0,15).
 E. Falls within JEDEC TO-252 variation AC.

PowerFLEX is a trademark of Texas Instruments.

D (R-PDSO-G8)

PLASTIC SMALL-OUTLINE PACKAGE

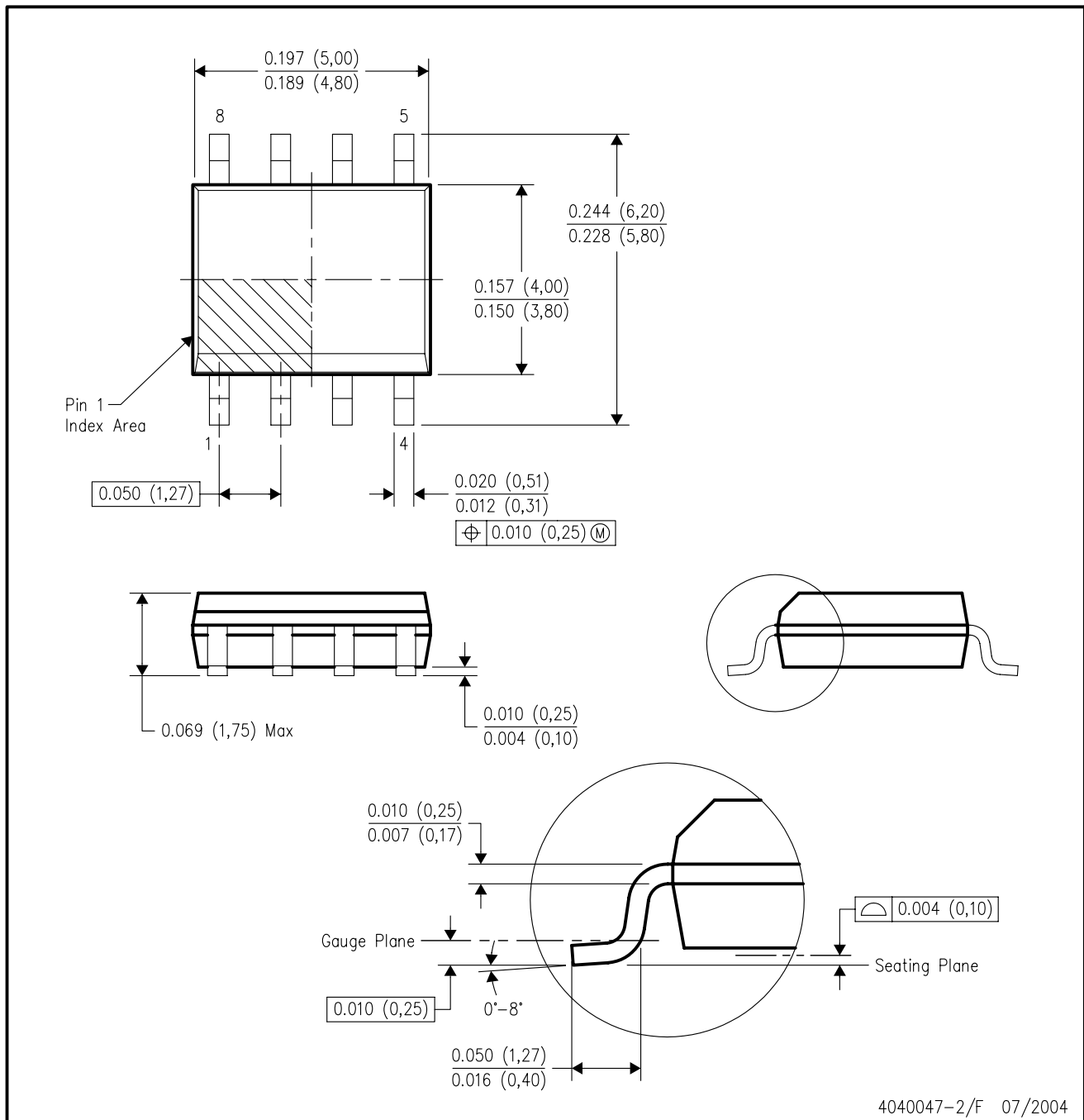

- NOTES:
- A. All linear dimensions are in inches (millimeters).
 - B. This drawing is subject to change without notice.
 - C. Body dimensions do not include mold flash or protrusion not to exceed 0.006 (0,15).
 - D. Falls within JEDEC MS-012 variation AA.

MECHANICAL DATA

PS (R-PDSO-G8)

PLASTIC SMALL-OUTLINE PACKAGE

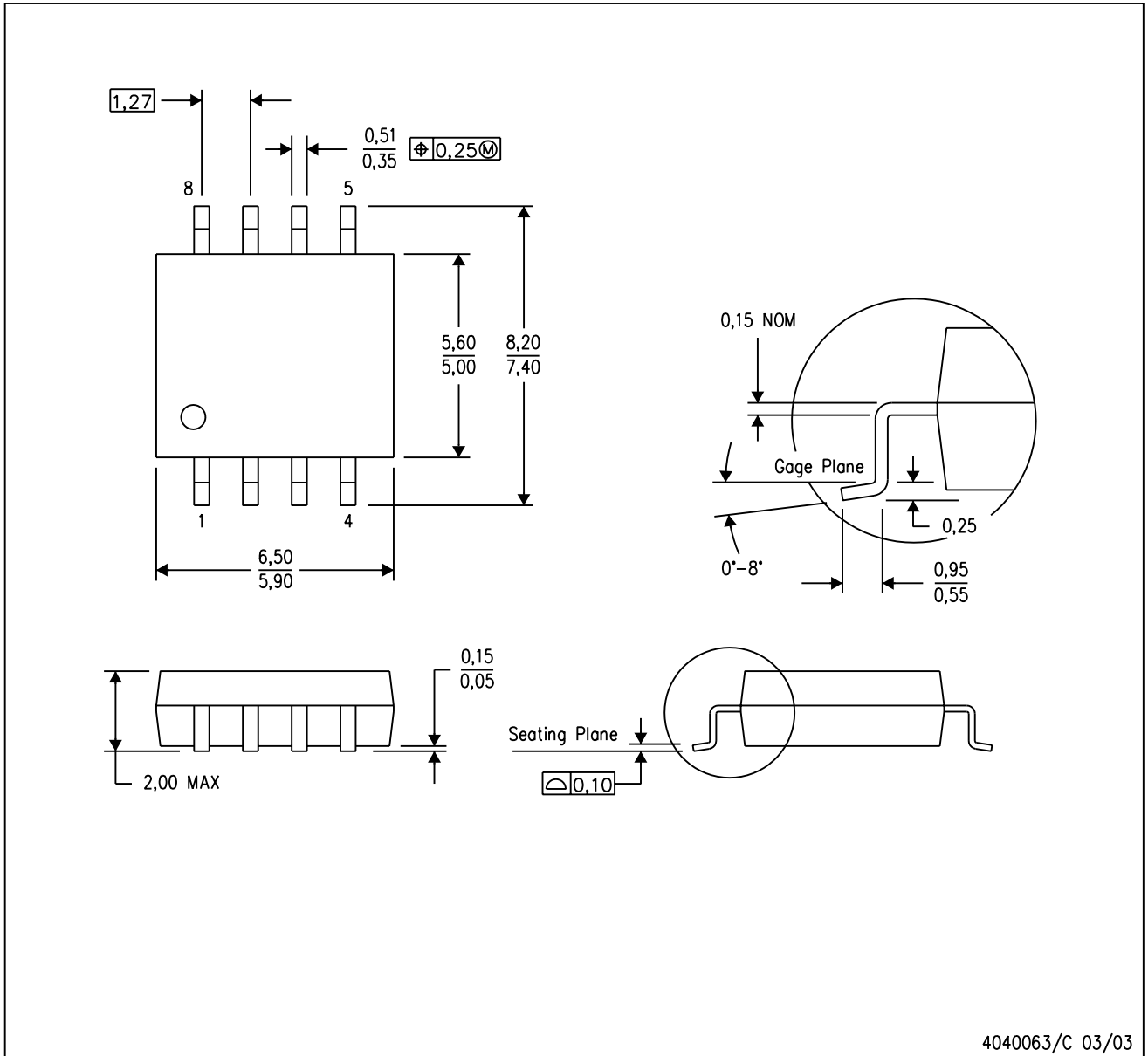

- NOTES:
- A. All linear dimensions are in millimeters.
 - B. This drawing is subject to change without notice.
 - C. Body dimensions do not include mold flash or protrusion, not to exceed 0,15.

LP (O-PBCY-W3)

PLASTIC CYLINDRICAL PACKAGE

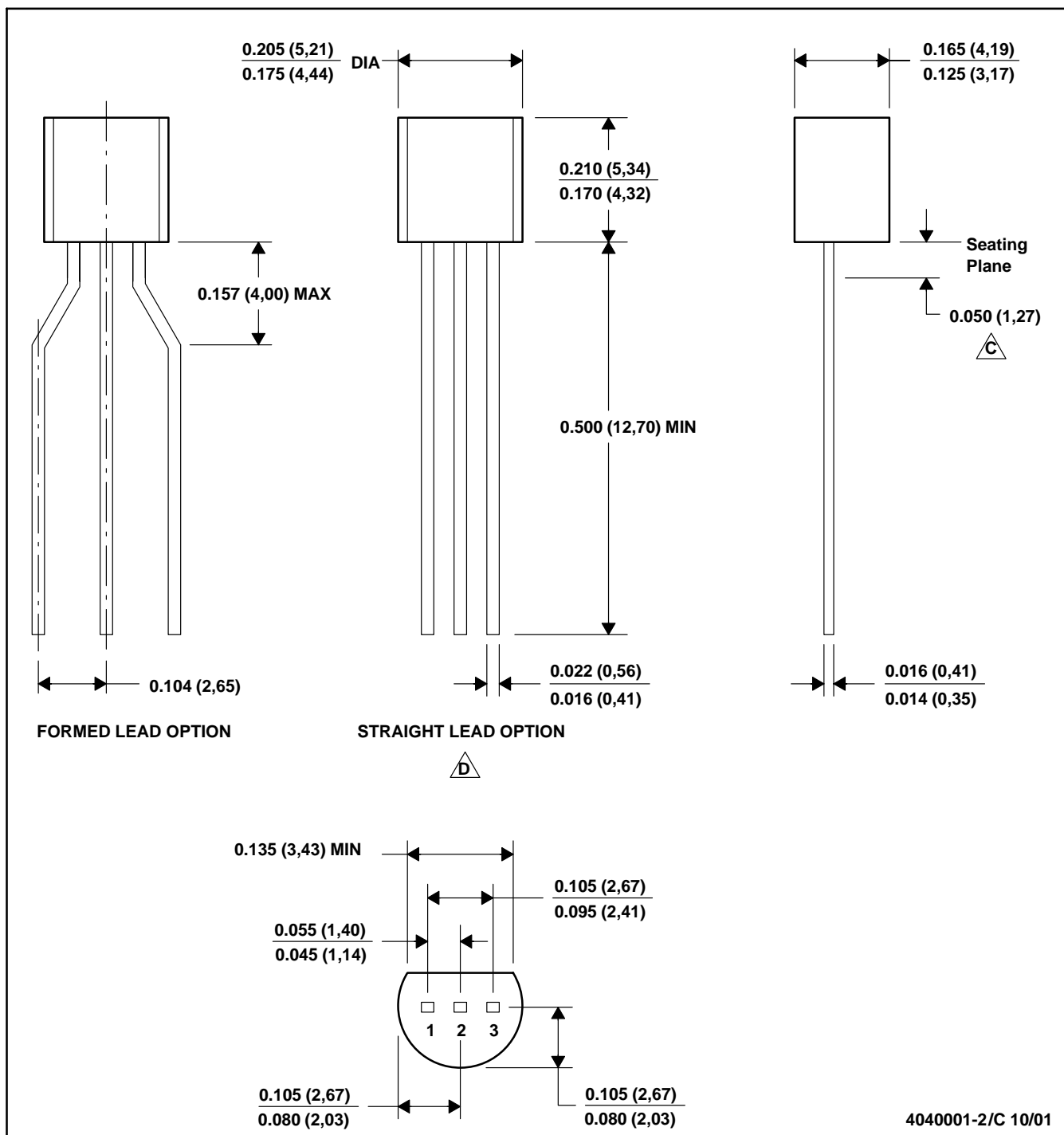

4040001-2/C 10/01

MECHANICAL DATA

MSOT002A – OCTOBER 1994 – REVISED NOVEMBER 2001

LP (O-PBCY-W3)

PLASTIC CYLINDRICAL PACKAGE

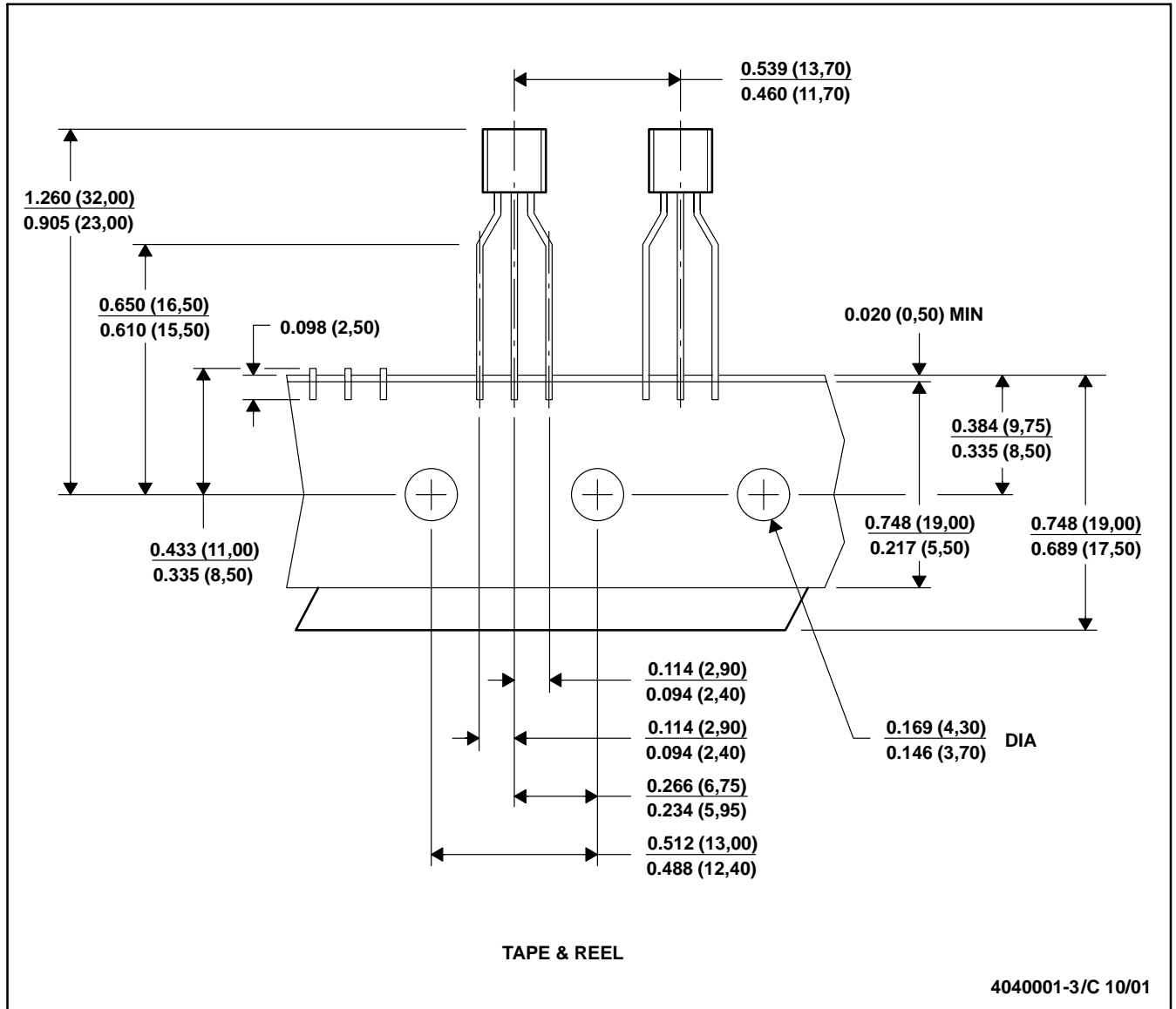

- NOTES:
- All linear dimensions are in inches (millimeters).
 - This drawing is subject to change without notice.
 - Tape and Reel information for the Format Lead Option package.

PW (R-PDSO-G**)

PLASTIC SMALL-OUTLINE PACKAGE

14 PINS SHOWN

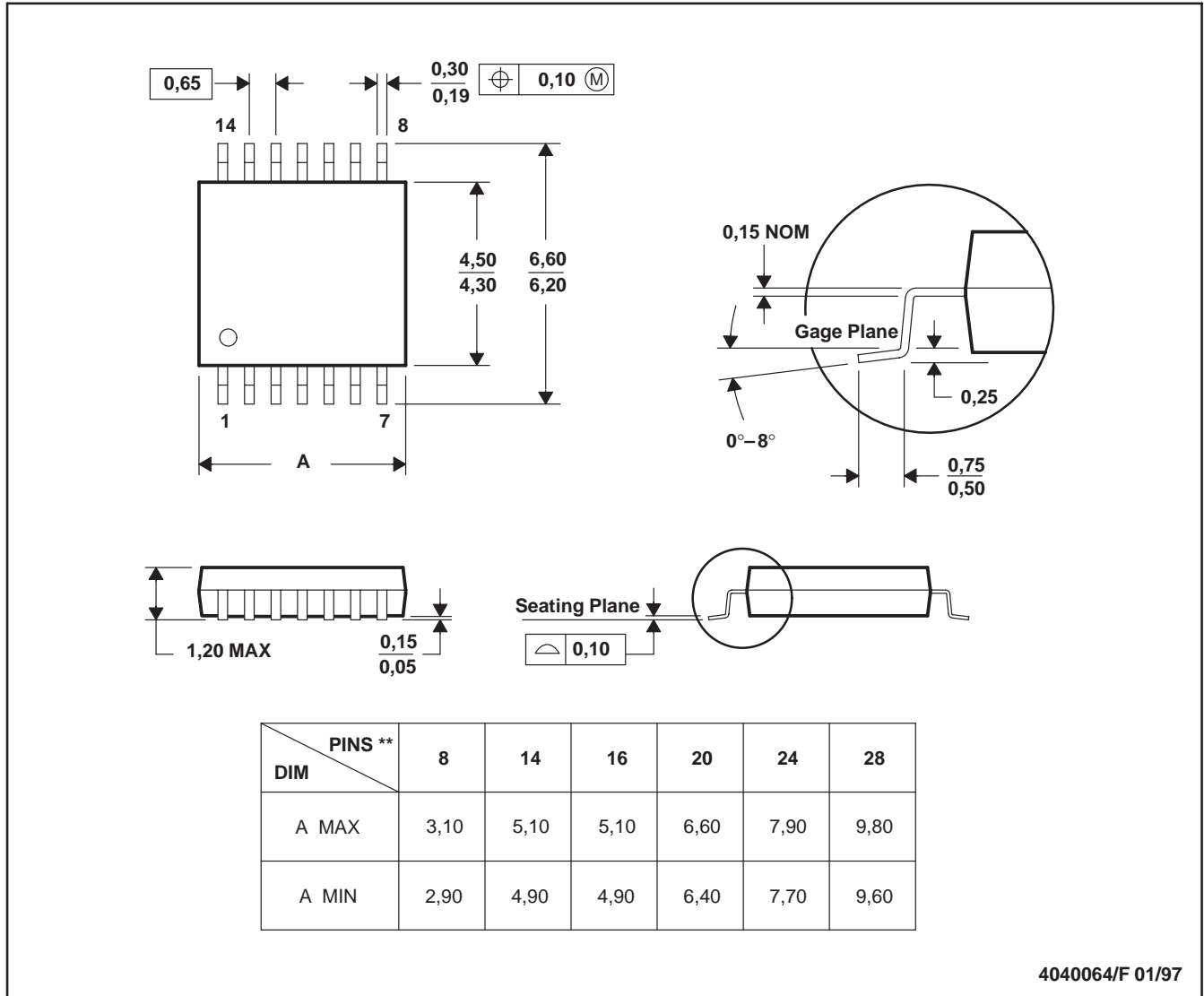

4040064/F 01/97

- NOTES: A. All linear dimensions are in millimeters.
 B. This drawing is subject to change without notice.
 C. Body dimensions do not include mold flash or protrusion not to exceed 0,15.
 D. Falls within JEDEC MO-153

IMPORTANT NOTICE

Texas Instruments Incorporated and its subsidiaries (TI) reserve the right to make corrections, modifications, enhancements, improvements, and other changes to its products and services at any time and to discontinue any product or service without notice. Customers should obtain the latest relevant information before placing orders and should verify that such information is current and complete. All products are sold subject to TI's terms and conditions of sale supplied at the time of order acknowledgment.

TI warrants performance of its hardware products to the specifications applicable at the time of sale in accordance with TI's standard warranty. Testing and other quality control techniques are used to the extent TI deems necessary to support this warranty. Except where mandated by government requirements, testing of all parameters of each product is not necessarily performed.

TI assumes no liability for applications assistance or customer product design. Customers are responsible for their products and applications using TI components. To minimize the risks associated with customer products and applications, customers should provide adequate design and operating safeguards.

TI does not warrant or represent that any license, either express or implied, is granted under any TI patent right, copyright, mask work right, or other TI intellectual property right relating to any combination, machine, or process in which TI products or services are used. Information published by TI regarding third-party products or services does not constitute a license from TI to use such products or services or a warranty or endorsement thereof. Use of such information may require a license from a third party under the patents or other intellectual property of the third party, or a license from TI under the patents or other intellectual property of TI.

Reproduction of information in TI data books or data sheets is permissible only if reproduction is without alteration and is accompanied by all associated warranties, conditions, limitations, and notices. Reproduction of this information with alteration is an unfair and deceptive business practice. TI is not responsible or liable for such altered documentation.

Resale of TI products or services with statements different from or beyond the parameters stated by TI for that product or service voids all express and any implied warranties for the associated TI product or service and is an unfair and deceptive business practice. TI is not responsible or liable for any such statements.

Following are URLs where you can obtain information on other Texas Instruments products and application solutions:

Products		Applications	
Amplifiers	amplifier.ti.com	Audio	www.ti.com/audio
Data Converters	dataconverter.ti.com	Automotive	www.ti.com/automotive
DSP	dsp.ti.com	Broadband	www.ti.com/broadband
Interface	interface.ti.com	Digital Control	www.ti.com/digitalcontrol
Logic	logic.ti.com	Military	www.ti.com/military
Power Mgmt	power.ti.com	Optical Networking	www.ti.com/opticalnetwork
Microcontrollers	microcontroller.ti.com	Security	www.ti.com/security
		Telephony	www.ti.com/telephony
		Video & Imaging	www.ti.com/video
		Wireless	www.ti.com/wireless

Mailing Address: Texas Instruments
Post Office Box 655303 Dallas, Texas 75265