

Hall Effect Latch For High Temperature

■ Features

- Bipolar Hall effect latch sensor
- 3.5V to 20V DC operation voltage
- Open collector pre-driver
- 25mA output sink current
- Chip power reverse-connection protection
- Operating temperature: -40°C~150°C
- Package: SIP3, SOT23

■ Applications

- Rotor position sensing
- Current switch
- Encoder
- RPM detection

■ Pin Assignment

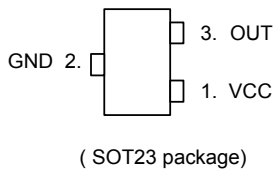
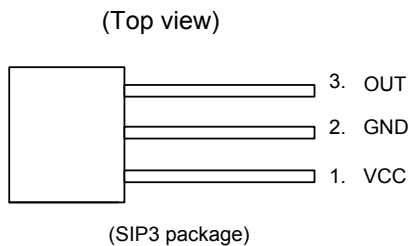

■ General Description

AH175 is a single-digital-output Hall-effect sensor for high temperature operation. The device includes an on-chip Hall voltage generator for magnetic sensing, an amplifier to amplify Hall voltage, and a comparator to provide switching hysteresis for noise rejection, and an open-collector output pre-driver. An internal bandgap regulator is used to provide temperature compensated supply voltage for internal circuits and allows a wide operating supply range.

While the magnetic flux density (B) is larger than threshold B_{op} , the OUT pin turns on (low). If B removed toward B_{rp} , the OUT pin is latched "on" state prior to $B < B_{rp}$. When $B < B_{rp}$, the OUT pin go into "off" state.

■ Pin Descriptions

Name	Description
VCC	Input power
GND	Ground
OUT	Output stage

■ Ordering Information

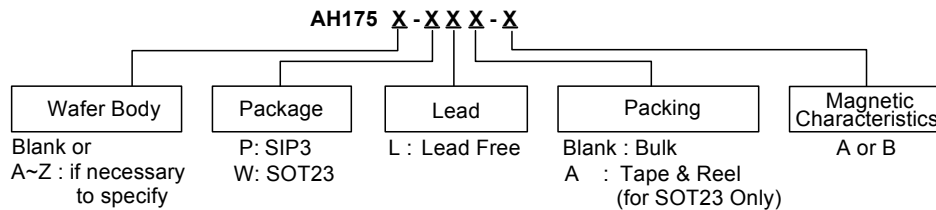

Hall Effect Latch For High Temperature

■ Block Diagram

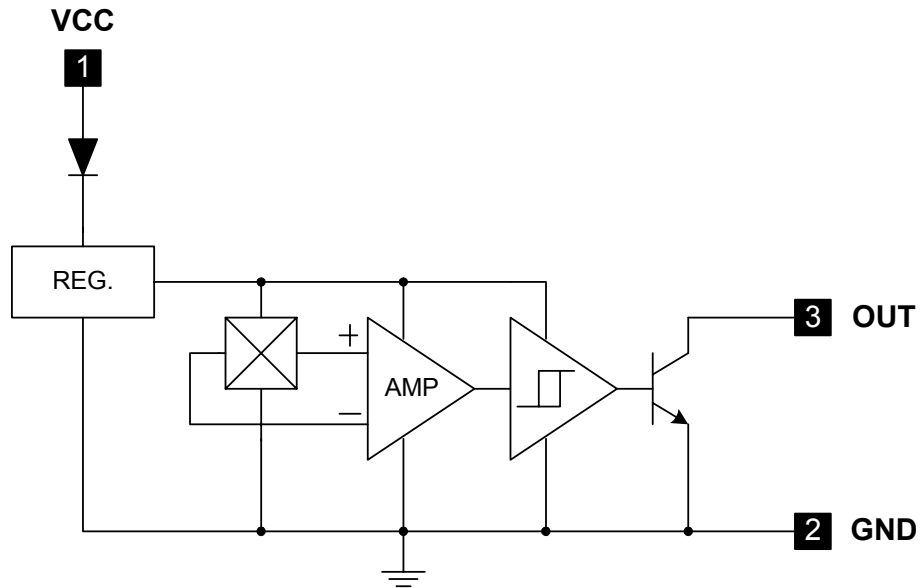

■ Application Circuit

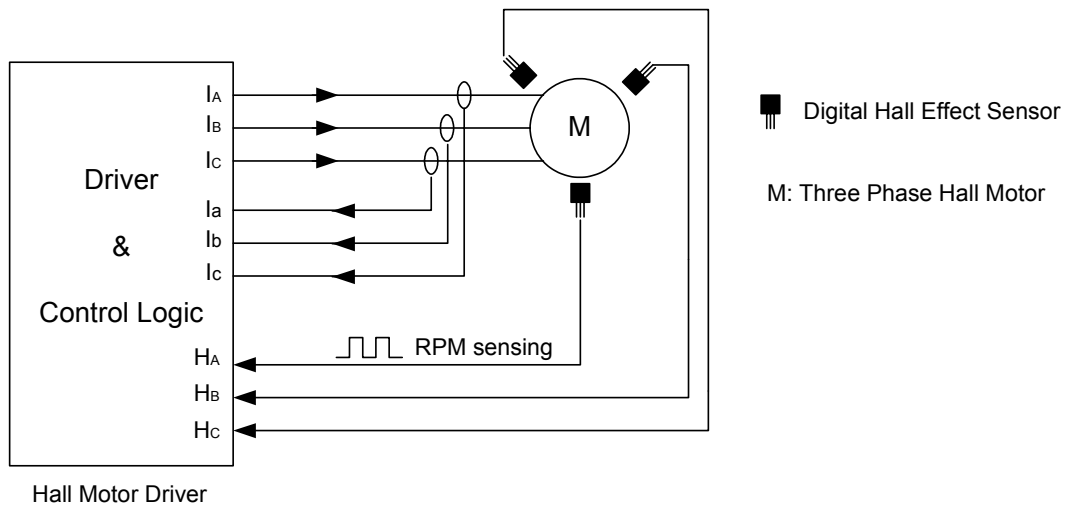

Three Phase Hall Motor

Hall Effect Latch For High Temperature

■ Absolute Maximum Ratings (At Ta= 25°C)

Parameter	Symbol	Rating	Unit
Supply Voltage	VCC	20	V
Output "OFF" Voltage	Vout (off)	20	V
Output "ON" Current	Io (sink)	25	mA
Operating Temperature Range	Top	-40~+150	°C
Storage Temperature Range	Tstg	-65~+150	°C
Maximum Junction Temperature	Tj	+150	°C
Power Dissipation	SIP	550	mW
	SOT23	230	mW

■ Electrical Characteristics (Ta= 25°C)

Parameter	Symbol	Conditions	Min.	Typ.	Max.	Unit
Supply Voltage	Vcc		3.5	-	20	V
Output Saturation Voltage	Vout(sat)	VCC=12V, OUT "ON" Io =10mA	-	300	400	mV
Supply Current	Icc	VCC=12V, OUT "OFF"	-	3.5	6	mA

■ Magnetic Characteristics (Ta= 25°C)

(1mT = 10 Gauss)

A grade

Parameter	Symbol	Min.	Typ.	Max.	Unit
Operate Point	Bop	15	-	60	Gauss
Release Point	Brp	-60	-	-15	Gauss
Hysteresis	Bhy	30	80	120	Gauss

B grade

Parameter	Symbol	Min.	Typ.	Max.	Unit
Operate Point	Bop	5	-	80	Gauss
Release Point	Brp	-80	-	-5	Gauss
Hysteresis	Bhy	10	80	160	Gauss

■ Operating Characteristics

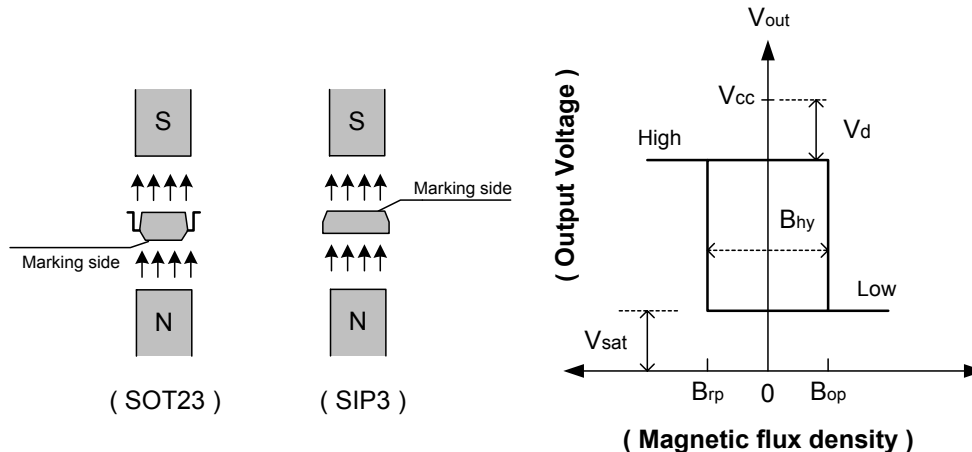

Hall Effect Latch For High Temperature

■ Performance Characteristics (SIP3)

Ta (°C)	25	50	60	70	80	85	90	95	100
Pd (mW)	550	440	396	352	308	286	264	242	220
Ta (°C)	105	110	115	120	125	130	135	140	150
Pd (mW)	198	176	154	132	110	88	66	44	0

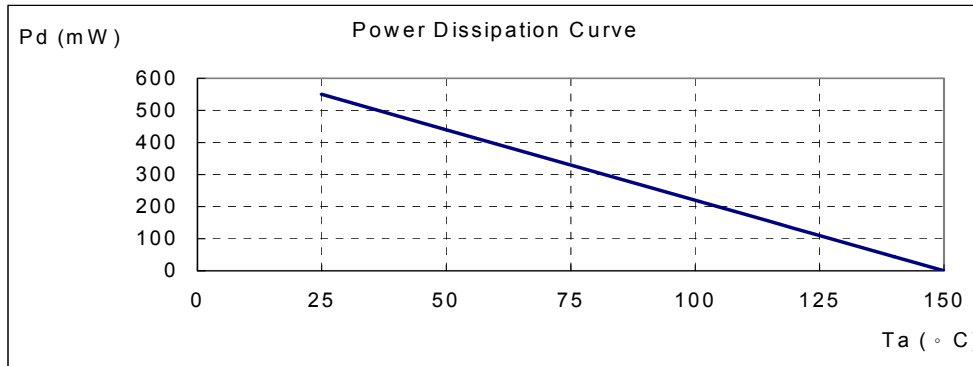

■ Performance Characteristics (SOT23-3)

Ta (°C)	25	50	60	70	80	90	100	110	120	125	130	140	150
Pd (mW)	230	184	166	147	129	110	92	74	55	46	37	18	0

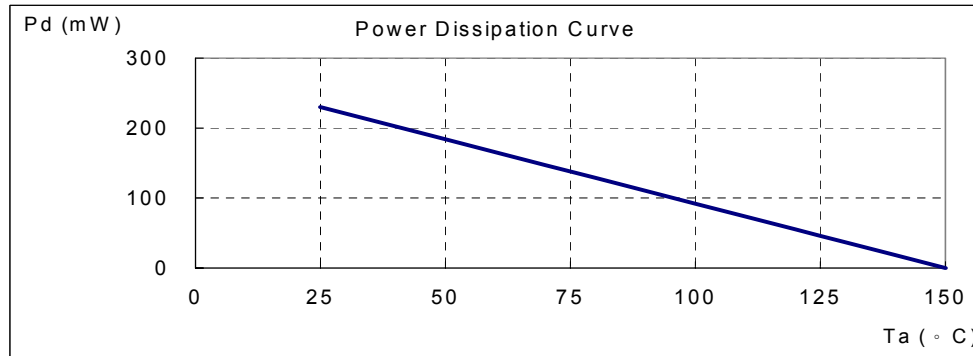

■ Marking Information

(1) SOT23

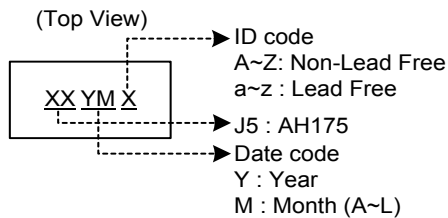

(2) SIP3

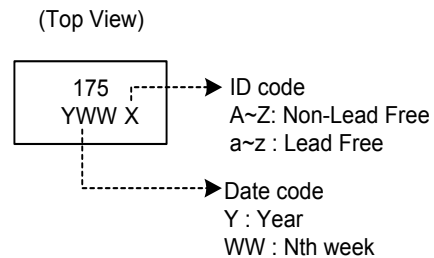

Hall Effect Latch For High Temperature

■ Package Information

(1) Package Type: SIP-3L

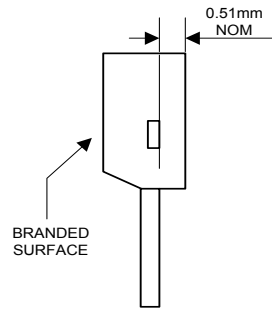

Active Area Depth

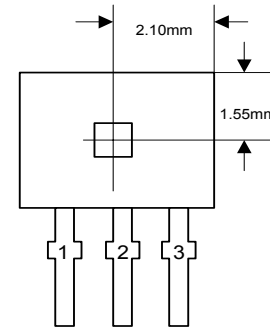

Sensor Location

Package Dimension

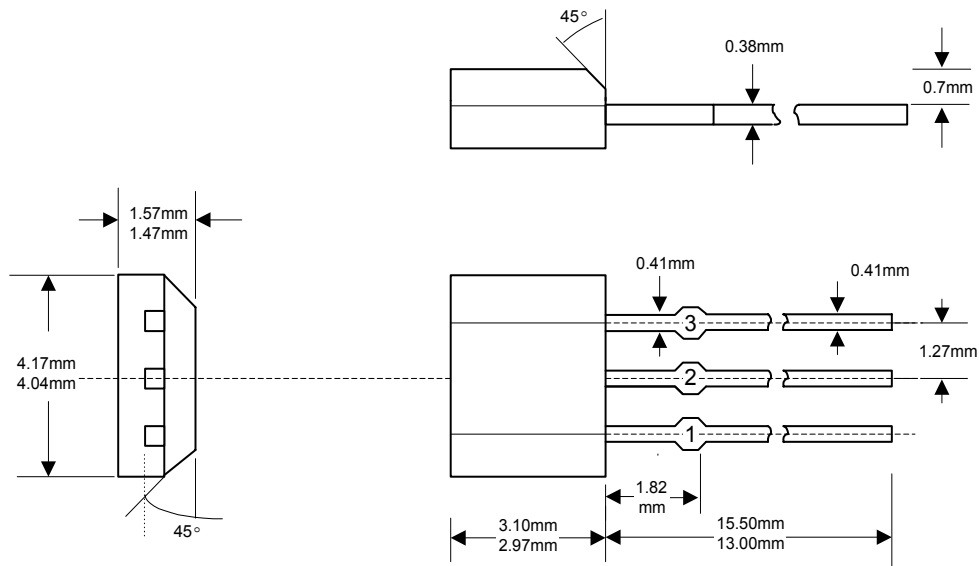

Hall Effect Latch For High Temperature

(2) Package Type: SOT23-3L

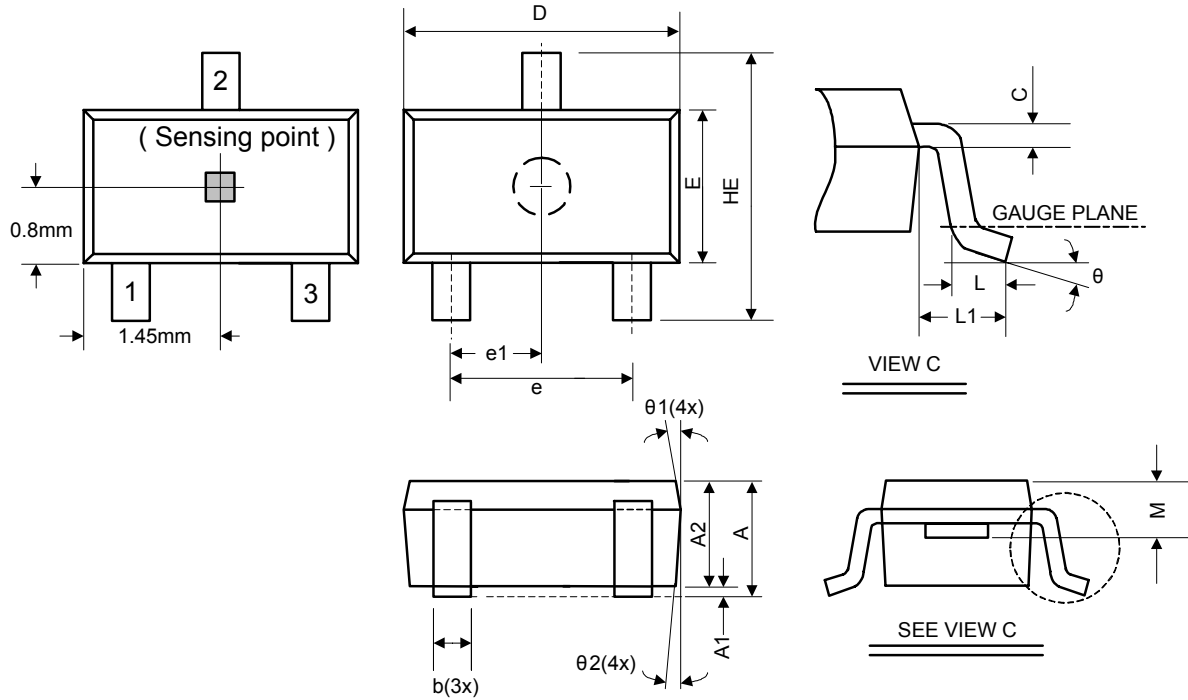

Symbol	Dimensions In Millimeters			Dimensions In Inches		
	Min.	Nom.	Max.	Min.	Nom.	Max.
A	1.05	-	1.35	0.041	-	0.053
A1	0.05	-	0.15	0.002	-	0.006
A2	1.00	1.10	1.20	0.039	0.043	0.047
b	0.25	-	0.50	0.010	-	0.020
C	0.08	-	0.20	0.003	-	0.008
D	2.70	2.90	3.00	0.106	0.114	0.118
E	1.50	1.60	1.70	0.059	0.063	0.067
HE	2.60	2.80	3.00	0.102	0.110	0.118
L	0.30	-	0.60	0.012	-	0.024
L1	0.50	0.60	0.70	0.020	0.024	0.028
M	0.73	0.78	0.83	0.029	0.031	0.033
e	1.80	1.90	2.00	0.071	0.075	0.079
e1	0.85	0.95	1.05	0.033	0.037	0.041
θ	0°	5°	10°	0°	5°	10°
θ_1	3°	5°	7°	3°	5°	7°
θ_2	6°	8°	10°	6°	8°	10°