

Telegesis		TG-ETRX35X-PM-010-102
ETRX351 and ETRX357		Product Manual

## ETRX35x ZIGBEE® MODULES

### PRODUCT MANUAL



## Table of Contents

<b>1</b>	<b>INTRODUCTION</b> .....	<b>5</b>
1.1	Hardware Description .....	5
<b>2</b>	<b>PRODUCT APPROVALS</b> .....	<b>6</b>
2.1	FCC Approvals.....	6
2.1.1	FCC Labelling Requirements.....	6
2.2	IC (Industry Canada) Approvals.....	7
2.3	European Certification (ETSI).....	7
2.4	ICASA Approvals .....	8
2.5	Australia and New Zealand (C-Tick).....	8
2.6	Declarations of Conformity.....	8
2.7	IEEE 802.15.4.....	8
2.8	The ZigBee® Protocol .....	8
<b>3</b>	<b>MODULE PINOUT</b> .....	<b>9</b>
<b>4</b>	<b>HARDWARE DESCRIPTION</b> .....	<b>11</b>
4.1	Hardware Interface .....	11
<b>5</b>	<b>FIRMWARE DESCRIPTION</b> .....	<b>12</b>
5.1	Custom Firmware.....	12
5.2	Software Interface.....	13
<b>6</b>	<b>ABSOLUTE MAXIMUM RATINGS</b> .....	<b>14</b>
6.1	Environmental Characteristics .....	14
6.2	Recommended Operating Conditions.....	14
<b>7</b>	<b>DC ELECTRICAL CHARACTERISTICS</b> .....	<b>15</b>
<b>8</b>	<b>DIGITAL I/O SPECIFICATIONS</b> .....	<b>17</b>
<b>9</b>	<b>A/D CONVERTER CHARACTERISTICS</b> .....	<b>18</b>
<b>10</b>	<b>AC ELECTRICAL CHARACTERISTICS</b> .....	<b>18</b>
10.1	TX Power Characteristics .....	20
<b>11</b>	<b>PHYSICAL DIMENSIONS</b> .....	<b>22</b>
<b>12</b>	<b>SOLDERING TEMPERATURE PROFILE (FOR REFLOW SOLDERING)</b> .....	<b>23</b>
12.1	For Leaded Solder .....	23
12.2	For Lead-free Solder.....	23
<b>13</b>	<b>PRODUCT LABEL DRAWING</b> .....	<b>24</b>
<b>14</b>	<b>RECOMMENDED FOOTPRINT</b> .....	<b>25</b>
14.1	Example carrier board.....	26
<b>15</b>	<b>RELIABILITY TESTS</b> .....	<b>27</b>
<b>16</b>	<b>APPLICATION NOTES</b> .....	<b>27</b>

---

16.1	Safety Precautions.....	27
16.2	Design Engineering Notes .....	27
16.3	Storage Conditions .....	28
<b>17</b>	<b>PACKAGING .....</b>	<b>28</b>
17.1	Embossed Tape.....	28
17.2	Component Orientation.....	29
17.3	Reel Dimensions.....	29
17.4	Packaging.....	29
<b>18</b>	<b>ORDERING INFORMATION .....</b>	<b>30</b>
<b>19</b>	<b>DISCLAIMER.....</b>	<b>31</b>
<b>20</b>	<b>ROHS DECLARATION.....</b>	<b>31</b>
<b>21</b>	<b>DATA SHEET STATUS.....</b>	<b>31</b>
<b>22</b>	<b>LIFE SUPPORT POLICY.....</b>	<b>31</b>
<b>23</b>	<b>RELATED DOCUMENTS.....</b>	<b>32</b>
<b>24</b>	<b>CONTACT INFORMATION .....</b>	<b>32</b>



Image not shown actual size; enlarged to show detail.

The Telegesis ETRX351 and ETRX357 modules are low power 2.4GHz ZigBee modules, based on the latest Ember EM351 and EM357 single chip ZigBee™ solutions.

These 3<sup>rd</sup> generation modules have been designed to be integrated into any device without the need for RF experience and expertise. Utilizing the EmberZNet ZigBee stack, the ETRX35x enables you to add powerful wireless networking capability to your products and quickly bring them to market.

The module's unique AT-style command line interface allows designers to quickly integrate ZigBee technology without complex software engineering. For custom application development the ETRX35x series integrates with ease into Ember's InSight development environment.

### Module Features

- Small form factor, SMT module 25mm x 19mm
- Side Castellations for easy soldering and optical inspection
- 2 antenna options: Integrated chip antenna or U.FL coaxial connector
- Industry's first ARM® Cortex-M3 based family of ZigBee modules
- Industry standard JTAG Programming and real time network level debugging via the Ember InSight Port
- 192kB (ETRX357) and 128kB (ETRX351) flash and 12kbytes of RAM
- Lowest Deep Sleep Current of sub 1µA and multiple sleep modes
- Wide supply voltage range (2.1 to 3.6V)
- Optional 32.768kHz watch crystal can be added externally
- Module ships with standard Telegesis AT-style command interface based on the ZigBee PRO feature set
- Can act as an End Device, Router or Coordinator
- 24 general-purpose I/O lines including analogue inputs (all GPIOs of the EM35x are accessible)
- Firmware upgrades via serial port or over the air (password protected)
- Hardware supported encryption (AES-128)
- CE, FCC and IC compliance, FCC modular approval
- Operating temperature range: -40°C to +85°C
- Long range version with a link budget of up to 124dB available in the same form factor

### Radio Features

- Based on the Ember EM351 or EM357 single chip ZigBee solutions
- 2.4GHz ISM Band
- 250kbit/s over the air data rate
- 16 channels (IEEE802.15.4 Channel 11 to 26)
- +3dBm output power ( +8dBm in boost mode)
- High sensitivity of -100dBm (-102dBm in boost mode) typically @ 1% packet error rate
- RX Current: 26mA, TX Current: 31mA at 3dBm
- Robust Wi-Fi and Bluetooth coexistence

### Suggested Applications

- AMR – ZigBee Smart Energy applications
- Wireless Alarms and Security
- Home/Building Automation
- Wireless Sensor Networks
- M2M Industrial Controls
- Lighting and ventilation control
- Remote monitoring
- Environmental monitoring and control

### Development Kit

- New Development kit containing everything required to set up a mesh network quickly and evaluate range and performance of the ETRX35x and its long-range version.
- AT-style software interface command dictionary can be modified for high volume customers.
- Custom software development available upon request.

### Example AT-Style Commands

AT+BCAST	Send a Broadcast
AT+UCAST:<address>	Send a Unicast
AT+EN	Establish PAN network
AT+JN	Join PAN

At power-up the last configuration is loaded from non-volatile S-Registers, which can eliminate the need for an additional host controller.

## 1 Introduction

This document describes the Telegesis ETRX351 and ETRX357 ZigBee® modules which have been designed to be easily integrated into another device and to provide a fast, simple and low cost wireless mesh networking interface.

The Telegesis ETRX3 series modules are based on the Ember ZigBee® platform consisting of the single chip EM351 or EM357 combined with the ZigBee® PRO compliant EmberZNet meshing stack. Integration into a wide range of applications is made easy using a simple AT style command interface and advanced hardware design.

The configurable functionality of the Telegesis AT Commandset often allows the ETRX3 series ZigBee® modules to be used without an additional host microcontroller saving even more integration time and costs. In addition to the Telegesis AT Commandset, the ETRX351 and ETRX357 modules can be used with custom-built firmware whilst representing an ideal platform for custom firmware development in conjunction with the Ember development kits.

No RF experience or expertise is required to add this powerful wireless networking capability to your products. The ETRX351 and ETRX357 offer fast integration opportunities and the shortest possible time to market for your product.

### 1.1 Hardware Description

The main building blocks of the ETRX351 and ETRX357 are the single chip EM351 and EM357 SoCs from Ember, a 24MHz reference crystal and RF front-end circuitry optimized for best RF performance. The modules are available with on-board antenna or alternatively a U.FL coaxial connector for attaching external antennae. Modules with the U.FL connector are identified by the “HR” suffix.

The integrated antenna is an Antenova Rufa, and details of the radiation pattern etc are available from the Antenova website [5].

Module	Chip	Flash	RAM
ETRX351	EM351	128kB	12kB
ETRX351HR	EM351	128kB	12kB
ETRX357	EM357	192kB	12kB
ETRX357HR	EM357	192kB	12kB

**Table 1: Memories**

The ETRX351 and ETRX357 are used for ZigBee® ([www.zigbee.org](http://www.zigbee.org)) applications. If you wish to create your own custom firmware, and not use the pre-loaded Telegesis AT-Command interface, you will need the Ember InSight toolchain, consisting of InSight Desktop™ together with a comprehensive integrated development environment (IDE). The Ember development environment is currently not suitable for developing an IEEE802.15.4-only application that does not use the ZigBee® layer.

## 2 Product Approvals

The ETRX351 and ETRX357 as well as the ETRX351HR and ETRX357HR have been designed to meet all national regulations for world-wide use. In particular the following certifications have been obtained:

### 2.1 FCC Approvals

The Telegesis ETRX351 and ETRX357 with integrated Antenna as well as the ETRX351HR and the ETRX357HR including the antennae listed in Table 2 have been tested to comply with FCC CFR Part 15 (USA) The devices meet the requirements for modular transmitter approval as detailed in the FCC public notice DA00.1407.transmitter. FCC statement:

***This device complies with Part 15 of the FCC rules. Operation is subject to the following two conditions: (1) this device may not cause harmful interference, and (2) this device must accept any interference received, including interference that may cause undesired operation.***



FCC ID: S4GEM35XA

Item	Part No.	Manufacturer	Type	Gain
1	BT-Stubby	EAD Ltd. [6]	¼ Wave	0dBi
2	WH-2400-U2.5	Wellhope Wireless [7]	½ Wave	2.5dBi

Table 2: Approved Antennae

While the applicant for a device into which the ETRX351 (ETRX357) or ETRX351HR (ETRX357HR) with an antenna listed in Table 2 is installed is not required to obtain a new authorization for the module, this does not preclude the possibility that some other form of authorization or testing may be required for the end product.

The FCC requires the user to be notified that any changes or modifications made to this device that are not expressly approved by Telegesis (UK) Ltd. may void the user's authority to operate the equipment.

When using the ETRX351HR and ETRX357HR with approved antennae, it is required to prevent end-users from replacing them with non-approved ones.

#### 2.1.1 FCC Labelling Requirements

When integrating the ETRX351, ETRX357, ETRX351HR or ETRX357HR into a product it must be ensured that the FCC labelling requirements are met. This includes a clearly visible label on the outside of the finished product specifying the Telegesis FCC identifier (**FCC ID: S4GEM35XA**) as well as the FCC notice shown on the previous page. This exterior label can use wording such as **“Contains Transmitter Module FCC ID: S4GEM35XA”** or **“Contains FCC ID:S4GEM35XA”** although any similar wording that expresses the same meaning may be used.

## 2.2 IC (Industry Canada) Approvals

The Telegesis ETRX351 and ETRX357 with integrated Antenna as well as the ETRX351HR and the ETRX357HR including the antennae listed in Table 2: Approved Antennae

have been tested to comply with IC.

### IC-ID: 8735A-EM35XA

The labelling requirements for Industry Canada are similar to those of the FCC. Again a clearly visible label must be placed on the outside of the finished product stating something like “Contains Transmitter Module, IC: 8735A-EM35XA”, although any similar wording that expresses the same meaning may be used.

The integrator is responsible for the final product to comply to IC ICES-003 and FCC Part 15, Sub. B – Unintentional Radiators.

## 2.3 European Certification (ETSI)

The ETRX351, ETRX357, ETRX351HR and ETRX357HR have been certified to the following standards:

- Radio: EN 300 328:V1.7.1
- EMC: EN 301 489-17:V2.1.1
- Safety: EN 60950-1:2005 (Ed. 2.0)

For this purpose the ETRX351HR and ETRX357HR have been tested with the antennae listed in Table 2.

If the ETRX351, ETRX357, ETRX351HR or ETRX357HR module is incorporated into an OEM product, the OEM product manufacturer must ensure compliance of the final product to the European Harmonised EMC, and low voltage/safety standards. A Declaration of Conformity must be issued for each of these standards and kept on file as described in Annex II of the R&TTE Directive. The final product must not exceed the specified power ratings, antenna specifications and installation requirements as specified in this user manual. If any of these specifications are exceeded in the final product then a submission must be made to a notified body for compliance testing to all of the required standards.

The ‘CE’ marking must be applied to a visible location on any OEM product. For more information please refer to <http://ec.europa.eu/enterprise/faq/ce-mark.htm>. Customers assume full responsibility for learning and meeting the required guidelines for each country in their distribution market.

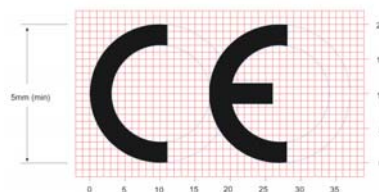

## 2.4 ICASA Approvals

The ETRX351, ETRX357, ETRX351HR and ETRX357HR have been certified to be used in South Africa.

## 2.5 Australia and New Zealand (C-Tick)

The ETRX351, ETRX357, ETRX351HR and ETRX357HR have been certified to be used in Australia and new Zealand.

## 2.6 Declarations of Conformity

Telegesis (UK) Ltd has issued Declarations of Conformity for all ETRX3 series ZigBee® RF Modules, which cover Radio Emissions, EMC and Safety. These documents are available from our website or on request.

## 2.7 IEEE 802.15.4

IEEE 802.15.4 is a standard for low data-rate, wireless networks (raw bit-rate within a radio packet of 250kbps @2.4GHz) which focuses on low cost, low duty cycle, long primary battery life applications as well as mains-powered applications. It is the basis for the open ZigBee® Protocol.

## 2.8 The ZigBee® Protocol

The ZigBee® Protocol is a set of standards for wireless connectivity for use between any devices over short to medium distances. The specification was originally ratified in December 2004, paving the way for companies to start making low-power networks a reality.

ZigBee® uses the IEEE 802.15.4 radio specification running on the 2.4GHz band, plus three additional layers for networking, security and applications. What makes the specification unique is its use of a mesh network architecture which, in bucket chain style, passes data from one node to the next until it lands at its destination. The network is self-healing and adapts its routing as link quality changes or nodes move. Furthermore, nodes can be defined as End Devices which do not act as routers, but can therefore be put into a low-power sleep state.

The enhanced version of the ZigBee® standard (or ZigBee® 2006) was released in December 2006, adding new features and improvements to the only global wireless communication standard enabling the development of easily deployable low-cost, low-power, monitoring and control products for homes, commercial buildings and industrial plant monitoring. In 2007 the ZigBee Alliance introduced the PRO featureset which offers advantages over earlier versions, including

- Truly self healing mesh networking
- Messages can now travel up to 30 hops
- Source-Routing for improved point to multipoint message transmission
- Improved security including Trust-Centre link keys
- New message types and options

The Telegesis AT Commandset, which by default ships on all ETRX3 series products is based on the ZigBee® PRO featureset. For more information on the Telegesis AT Commandset please refer to the separate documentation at [www.telegesis.com](http://www.telegesis.com).

### 3 Module Pinout

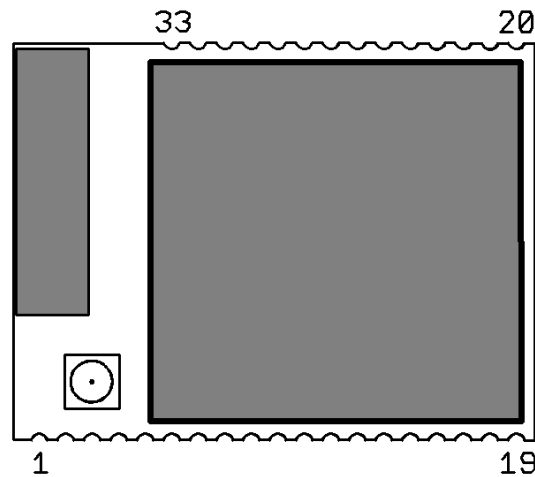

**Figure 1: ETRX3 series Module Pinout (top view)**

The table below gives details about the pin assignment for direct SMD soldering of the ETRX3 series modules to the application board. For more information on the alternate functions please refer to [2]. Also refer to the Telegesis AT Commandset documentation and the Telegesis development kit documentation to understand how the pre-programmed firmware makes use of the individual I/Os.

All GND pads are connected within the module, but for best RF performance all of them should be grounded externally ideally to a ground plane.

ETRX35x Pad	Name	EM35x Pin	Default use	Alternate Functions
1	GND	GND	GND	
2	PC5 {1}	11		TX_ACTIVE
3	PC6	13	O/P	OSC32B, nTX_ACTIVE
4	PC7	14	O/P	OSC32A, OSC32_EXT
5	PA7 {5}	18	O/P	TIM1C4
6	PB3 {2,3}	19	O/P, CTS	SC1nCTS, SC1SCLK, TIM2C3
7	nReset	12	nReset	
8	PB4 {2,3}	20	O/P, RTS	TIM2C4, SC1nRTS, SC1nSSEL
9	PA0	21	O/P	TIM2C1, SC2MOSI
10	PA1	22	O/P	TIM2C3, SC2SDA, SC2MISO
11	PA2	24	O/P	TIM2C4, SC2SCL, SC2SCLK
12	PA3	25	O/P	SC2nSSEL, TRACECLK, TIM2C2
13	GND	GND	GND	
14	PA4	26	O/P	ADC4, PTI_EN, TRACEDATA
15	PA5 {4}	27	O/P	ADC5, PTI_DATA, nBOOTMODE, TRACEDATA3
16	PA6 {5}	29	O/P	TIM1C3
17	PB1 {3}	30	TXD	SC1MISO, SC1MOSI, SC1SDA, SC1TXD, TIM2C1
18	PB2 {3}	31	RXD	SC1MISO, SC1MOSI, SC1SCL, SC1RXD, TIM2C2
19	GND	GND	GND	

ETRX35x Pad	Name	EM35x Pin	Default use	Alternate Functions
20	GND	GND	GND	
21	JTCK	32		SWCLK
22	PC2	33	O/P	JTDO, SWO
23	PC3	34	O/P	JTDI
24	PC4	35	O/P	JTMS, SWDIO
25	PB0	36	I/P, IRQ	VREF, IRQA, TRACECLK, TIM1CLK, TIM2MSK
26	PC1	38	ADC	ADC3, SWO, TRACEDATA0
27	PC0 {5}	40	O/P	JRST, IRQD, TRACEDATA1
28	PB7 {5}	41	ADC	ADC2, IRQC, TIM1C2
29	PB6 {5}	42	ADC	ADC1, IRQB, TIM1C1
30	PB5	43	ADC	ADC0, TIM2CLK, TIM1MSK
31	GND	GND	GND	
32	Vcc	Vcc	Vcc	
33	GND	GND	GND	

**Table 3: Pin Information**
**Notes:**

- {1} When the alternate function is selected, TX\_ACTIVE becomes an output that indicates that the EM35x radio circuit is in transmit mode. PC5 is not usable on the long range version of the ETRX35x as this GPIO is used internally as TX\_ACTIVE to control the external RF frontend.
- {2} The serial UART connections TXD, RXD, CTS and RTS are PB1, PB2, PB3 and PB4 respectively
- {3} When using the Telegesis AT Commandset, RTS/CTS handshaking is selectable in firmware. See the AT Command Manual.
- {4} If PA5 is driven low at power-up or reset the module will boot up in the bootloader
- {5} PA6, PA7, PB6, PB7 and PC0 can drive high current (see section 8)

See also the table "Module pads and functions" in the ETRX357 Development Kit Product Manual.

## 4 Hardware Description

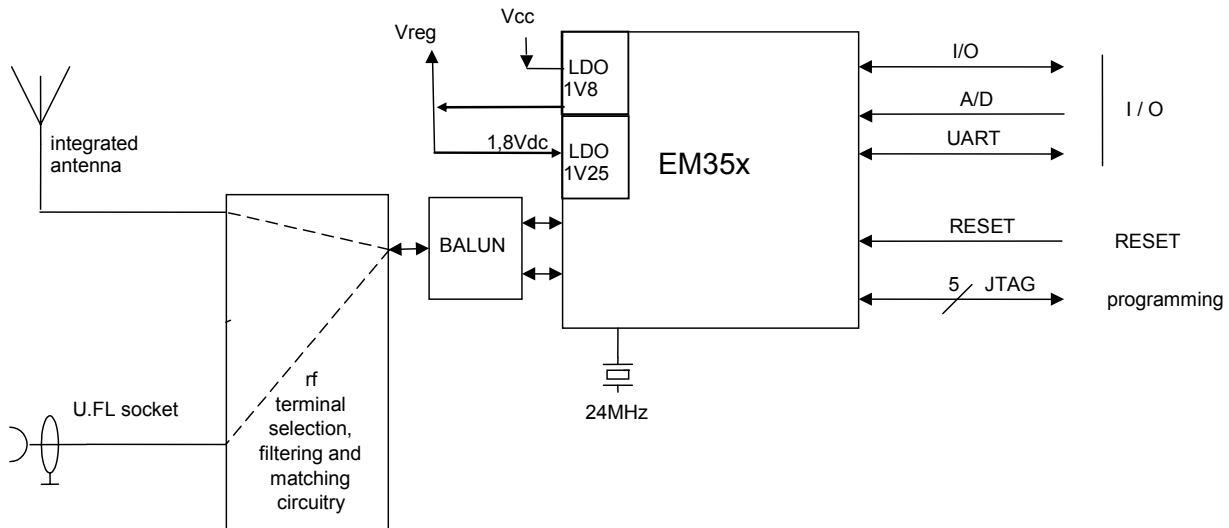

**Figure 2: Hardware Diagram**

The ETRX351, ETRX351HR, ETRX357 and ETRX357HR are based on the Ember EM351 and EM357 respectively. The EM351 and EM357 are fully integrated 2.4GHz ZigBee transceivers with a 32-bit ARM<sup>®</sup> Cortex M3<sup>™</sup> microprocessor, flash and RAM memory, and peripherals.

The industry standard serial wire and JTAG programming and debugging interfaces together with the standard ARM system debug components help to streamline any custom software development.

In addition to this a number of MAC functions are also implemented in hardware to help maintaining the strict timing requirements imposed by the ZigBee and IEEE802.15.4 standards.

The new advanced power management features allow faster wakeup from sleep and new power down modes allowing this 3<sup>rd</sup> generation module to offer a longer battery life than any 2<sup>nd</sup> generation modules on the market.

The EM35x has fully integrated voltage regulators for both required 1.8V and 1.25V supply voltages. The voltages are monitored (brown-out detection) and the built in power-on-reset circuit eliminates the need for any external monitoring circuitry. An optional 32.768 kHz watch crystal can be connected externally to pads 3 and 4 in case more accurate timing is required. To utilize the external watch crystal custom firmware is required.

### 4.1 Hardware Interface

All GPIO pins of the EM351 or EM357 are accessible on the module's pads. Whether signals are used as general purpose I/Os, or assigned to a peripheral function like ADC is set by the firmware. When using the Telegesis AT Commandset please refer to the AT Commandset manual and the development kit manual for this information and when developing custom firmware please refer to the EM35x datasheet [2].

## 5 Firmware Description

The modules will be pre-loaded with a standalone bootloader which supports over-the-air bootloading as well as serial bootloading of new firmware.

In order to enter the standalone bootloader using a hardware trigger pull PA5 to ground and power-cycle or reset the module. To avoid entering the standalone bootloader unintentionally make sure not to pull this pin down during boot-up unless the resistance to ground is  $>10k\Omega$ . (A pull-up is not required).

In addition to the standalone bootloader the modules also contain the current release of the Telegesis AT-style command interface as described in the Telegesis AT command dictionary and the Telegesis user guide. Check [www.telegesis.com](http://www.telegesis.com) for updates. Each module comes with a unique 64-bit 802.15.4 identifier which is stored in non-volatile memory. The commands and responses pass through the serial port of the ETRX35x as ASCII text, so a simple terminal application will usually suffice. We provide Telegesis Terminal for interaction with the module but it is not an essential feature.

The pre-loaded AT-style command interface firmware is based on the latest EmberZNet meshing stack which implements routers/coordinators as well as (sleepy) end devices. [End devices have no routing responsibility and therefore are allowed to go to sleep, whilst still being able to send and receive messages via a parent router. In addition to classical sleepy and non-sleepy end devices the module firmware also supports mobile (sleepy) end devices capable of changing their parent quickly whenever they change their position within the network.]

A router is typically a mains powered device whilst a sleepy end device (SED) can be battery powered.

The module is also able to act as a coordinator and Trust Centre through external host control. The AT style command line supplies all the tools required to set up and manage a ZigBee network by allowing easy access to the low-level functionality of the stack.

The Telegesis firmware uses the meshing and self healing EmberZNet PRO stack to overcome many of the limitations of the tree network topology of the ZigBee® 2006 stack by using the ZigBee PRO featureset.

The Telegesis firmware allows low-level access to physical parameters such as channel and power level. Parameters that define the functionality of the ETRX35x module and also allow standalone functionality are saved in non-volatile memory organised in so-called S-Registers. The SPI and I2C buses are not supported by the current firmware release, but can be used with custom firmware.

### 5.1 Custom Firmware

For high volume customers the firmware can be customised on request. In addition to this the ETRX3 series of modules is an ideal platform for developing custom firmware. In order to develop custom firmware the Ember Insight toolchain is required.

## 5.2 Software Interface

Using the default firmware the ETRX35x is controlled using a simple AT-style command interface and (mostly) non-volatile S-Registers. In order to get a full listing of all the available AT-Commands, please refer to the AT command dictionary document which corresponds to the firmware revision you intend to use.

In addition to the command dictionary there are user guides explaining the features of the firmware in more detail. If you need to find out which firmware resides on your module simply type “**ATI**” followed by a carriage return and you will be prompted with the module’s manufacturing information.

The Development Kit manual describes how to upgrade the firmware either via a serial link or over the air.

## 6 Absolute Maximum Ratings

No.	Item	Symbol	Absolute Maximum Ratings	Unit
1	Supply voltage	$V_{CC}$	-0.3 to +3.6	Vdc
2	Voltage on any Pad	$V_{in}$	-0.3 to $V_{CC} + 0.3$	Vdc
3	Voltage on any Pad pin (PA4, PA5, PB5, PB6, PB7, PC1), when used as an input to the general purpose ADC with the low voltage range selected	$V_{in}$	-0.3 to +2.0	Vdc
4	Storage temperature range	$T_{stg}$	-40 to +105	°C
5	Operating temperature range	$T_{op}$	-40 to +85	°C
6	Input RF level	$P_{max}$	15	dBm
8	Reflow temperature	$T_{Death}$	Please refer to chapter 12	°C

**Table 4: Absolute Maximum Ratings**

The absolute maximum ratings given above should under no circumstances be violated. Exceeding one or more of the limiting values may cause permanent damage to the device.



Caution! ESD sensitive device. Precautions should be used when handling the device in order to prevent permanent damage.

### 6.1 Environmental Characteristics

No.	Item	Symbol	Absolute Maximum Ratings	Unit
1	ESD on any pad according to Human Body Model (HBM) circuit description	$V_{THHBM}$	±2	kV
2	ESD on non-RF pads according to Charged Device Model (CDM) circuit description	$V_{THCDM}$	±400	V
3	ESD on RF terminal according to Charged Device Model (CDM) circuit description	$V_{THCDM}$	±225	V
4	Moisture Sensitivity Level	MSL	MSL3	

**Table 5: Absolute Maximum Ratings**

### 6.2 Recommended Operating Conditions

No.	Item	Condition / Remark	Symbol	Value			Unit
				Min	Typ	Max	
1	Supply voltage		$V_{CC}$	2.1		3.6	Vdc
2	RF Input Frequency		$f_C$	2405		2480	MHz
3	RF Input Power		$P_{IN}$			0	dBm
4	Operating temperature range		$T_{op}$	-40		+85	°C

**Table 6: Recommended Operating Conditions**

## 7 DC Electrical Characteristics

$V_{CC} = 3.0V$ ,  $T_{AMB} = 25^{\circ}C$ , NORMAL MODE (non-Boost) unless otherwise stated

No.	Item	Condition / Remark	Symbol	Value			Unit
				Min	Typ	Max	
1	Module supply voltage		$V_{CC}$	2.1		3.6	Vdc
<b>Deep Sleep Current</b>							
2	Quiescent current, internal RC oscillator disabled		$I_{SLEEP}$		0.4		$\mu A$
3	Quiescent current, internal RC oscillator enabled		$I_{SLEEP}$		0.7		$\mu A$
4	Quiescent current, including 32.768kHz oscillator		$I_{SLEEP}$		1.0		$\mu A$
5	Quiescent current including internal RC oscillator and 32.768kHz oscillator		$I_{SLEEP}$		1.3		$\mu A$
<b>Reset Current</b>							
6	Quiescent current nReset asserted		$I_{RESET}$		1.2	2.0	mA
<b>Processor and Peripheral Currents</b>							
7	ARM <sup>®</sup> Cortex <sup>™</sup> M3, RAM and flash memory	25°C, 12MHz Core clock	$I_{MCU}$		6.0		mA
8	ARM <sup>®</sup> Cortex <sup>™</sup> M3, RAM and flash memory	25°C, 24MHz Core clock	$I_{MCU}$		7.5		mA
9	ARM <sup>®</sup> Cortex <sup>™</sup> M3, RAM and flash memory sleep current	25°C, 12MHz Core clock	$I_{MCU}$		3.0		mA
10	ARM <sup>®</sup> Cortex <sup>™</sup> M3, RAM and flash memory sleep current	25°C, 6MHz Core clock	$I_{MCU}$		2.0		mA
11	Serial controller current	Per serial controller at max. clock rate	$I_{SC}$		0.2		mA
12	General purpose timer current	Per timer at max. clock rate	$I_{TIM}$		0.25		mA
13	General purpose ADC current	Max. Sample rate, DMA	$I_{ADC}$		1.1		mA
<b>RX Current</b>							
14	Radio receiver MAC and Baseband	ARM <sup>®</sup> Cortex <sup>™</sup> M3 sleeping.	$I_{RX}$		22		mA
15	Receive current consumption	Total, 12MHz clock speed	$I_{RX}$		25		mA
16	Receive current consumption	Total, 24MHz clock speed	$I_{RX}$		26.5		mA
17	Receive current consumption BOOST MODE	Total, 12MHz clock speed	$I_{RX}$		27		mA
18	Receive current consumption BOOST MODE	Total, 24MHz clock speed	$I_{RX}$		28.5		mA
<b>TX Current</b>							
19	Transmit current consumption	at +3dBm module output power	$I_{TXVCC}$		31		mA
20	Transmit Current consumption BOOST MODE	at +8dBm module output power	$I_{TXVCC}$		42		mA

21	Transmit current consumption	at +0dBm module output power	$I_{TXVCC}$		28.5		mA
22	Transmit current consumption	at min. module output power	$I_{TXVCC}$		23.5		mA
23	Wake time from deep sleep	From wakeup event to 1 <sup>st</sup> instruction			100		$\mu$ s
24	Shutdown time	From last instruction into deep sleep			5		$\mu$ s

**Table 7: DC Electrical Characteristics**

**Please Note:** The average current consumption during operation is dependent on the firmware and the network load, therefore these figures are provided in the command dictionary of the respective firmware.

## 8 Digital I/O Specifications

The digital I/Os of the ETRX35x module

$V_{CC} = 3.0V$ ,  $T_{AMB} = 25^{\circ}C$ , NORMAL MODE unless otherwise stated

No.	Item	Condition / Remark	Symbol	Value			Unit
				Min	Typ	Max	
1	Low Schmitt switching threshold	Schmitt input threshold going from high to low	$V_{SWIL}$	$0.42 \times V_{CC}$		$0.5 \times V_{CC}$	Vdc
2	High Schmitt switching threshold	Schmitt input threshold going from low to high	$V_{SWIH}$	$0.62 \times V_{CC}$		$0.8 \times V_{CC}$	MHz
3	Input current for logic 0		$I_{IL}$			-0.5	$\mu A$
4	Input current for logic 1		$I_{IH}$			0.5	$\mu A$
5	Input Pull-up resistor value		$R_{IPU}$	24	29	34	k $\Omega$
6	Input Pull-down resistor value		$R_{IPD}$	24	29	34	k $\Omega$
7	Output voltage for logic 0	$I_{OL} = 4mA$ (8mA) for standard (high current) pads	$V_{OL}$	0		$0.18 \times V_{CC}$	V
8	Output voltage for logic 1	$I_{OH} = 4mA$ (8mA) for standard (high current) pads	$V_{OH}$	$0.82 \times V_{CC}$		$V_{CC}$	V
9	Output Source Current	Standard current pad	$I_{OHS}$			4	mA
10	Output Sink current	Standard current pad	$I_{OLS}$			4	mA
11	Output Source Current	High current pad	$I_{OHH}$			8	mA
12	Output Sink current	High current pad	$I_{OLH}$			8	mA
13	Total output current		$I_{OH} + I_{OL}$			40	mA

**Table 8. Digital I/O Specifications**

## 9 A/D Converter Characteristics

The ADC is a first-order sigma-delta converter. For additional information on the ADC please refer to section 10 of the EM35x datasheet.

No.	Item	
1	A/D resolution	Up to 12 bits
2	A/D sample time for 5-bit conversion	5.33µs
3	A/D sample time for 12-bit conversion	682µs
4	Reference Voltage	1.25V or V <sub>CC</sub>

**Table 9. A/D Converter Characteristics**

## 10 AC Electrical Characteristics

V<sub>CC</sub> = 3.0V, T<sub>AMB</sub> = 25°C, NORMAL MODE measured at 50Ω terminal load connected to the U.FL socket

No.	Receiver	Value			Unit
		Min	Typ	Max	
1	Frequency range	2400		2500	MHz
2	Sensitivity for 1% Packet Error Rate (PER)		-100	-94	dBm
3	Sensitivity for 1% Packet Error Rate (PER) BOOST MODE		-102	-96	dBm
4	Saturation (maximum input level for correct operation)	0			dBm
5	High-Side Adjacent Channel Rejection (1% PER and desired signal -82dBm acc. to [1])		35		dB
6	Low-Side Adjacent Channel Rejection (1% PER and desired signal -82dBm acc. to [1])		35		dB
7	2 <sup>nd</sup> High-Side Adjacent Channel Rejection (1% PER and desired signal -82dBm acc. to [1])		46		
8	2 <sup>nd</sup> Low-Side Adjacent Channel Rejection (1% PER and desired signal -82dBm acc. to [1])		46		
9	Channel Rejection for all other channels (1% PER and desired signal -82dBm acc. to [1])		40		dB
10	802.11g rejection centred at +12MHz or -13MHz (1% PER and desired signal -82dBm acc. to [1])		36		dB
11	Co-channel rejection (1% PER and desired signal -82dBm acc. to [1])		-6		dBc
12	Relative frequency error (2x40ppm required by [1])	-120		120	ppm
13	Relative timing error (2x40ppm required by [1])	-120		120	ppm
14	Linear RSSI range	40			dB
15	Output power at highest power setting NORMAL MODE BOOST MODE	0	3 8		dBm
16	Output power at lowest power setting		-55		dBm
17	Error vector magnitude as per IEEE802.15.4		5	15	%
18	Carrier frequency error	-40		40	ppm
19	PSD mask relative 3.5MHz distance from carrier	-20			dB
20	PSD mask absolute 3.5MHz distance from carrier	-30			dBm

**Table 10. AC Electrical Characteristics**

**Please Note:** For the relationship between EM35x power settings and module output power please refer to chapter 10.1 of this document. When developing custom firmware the output power settings described in this document relate directly to the EM35x power settings accessible via the Ember stack API.

No.	Synthesiser Characteristics	Limit			Unit
		Min	Typ	Max	
22	Frequency range	2400		2500	MHz
23	Frequency resolution		11.7		kHz
24	Lock time from off state, with correct VCO DAC settings			100	µs
25	Relock time, channel change or Rx/Tx turnaround			100	µs
26	Phase noise at 100kHz offset		-75dBc/Hz		
27	Phase noise at 1MHz offset		-100dBc/Hz		
28	Phase noise at 4MHz offset		-108dBc/Hz		
29	Phase noise at 10MHz offset		-114dBc/Hz		

**Table 11: Synthesiser Characteristics**

No.	Power On Reset (POR) Specifications	Limit			Unit
		Min	Typ	Max	
30	V <sub>CC</sub> POR release	0.62	0.95	1.2	Vdc
31	V <sub>CC</sub> POR assert	0.45	0.65	0.85	Vdc

**Table 12: Power On Reset Specifications**

No.	nRESET Specifications	Limit			Unit
		Min	Typ	Max	
32	Reset Filter Time constant	2.1	12	16	µs
33	Reset Pulse width to guarantee a reset	26			µs
34	Reset Pulse width guaranteed not to cause reset	0		1	µs

**Table 13: nReset Specifications**

**10.1 TX Power Characteristics**

The diagrams below show the typical output power and module current in dependency on module EM35x power setting . Power settings above 3dBm have Boost Mode enabled. Please note that the output power is independent of the supply voltage as the radio is supplied by an internally regulated voltage.

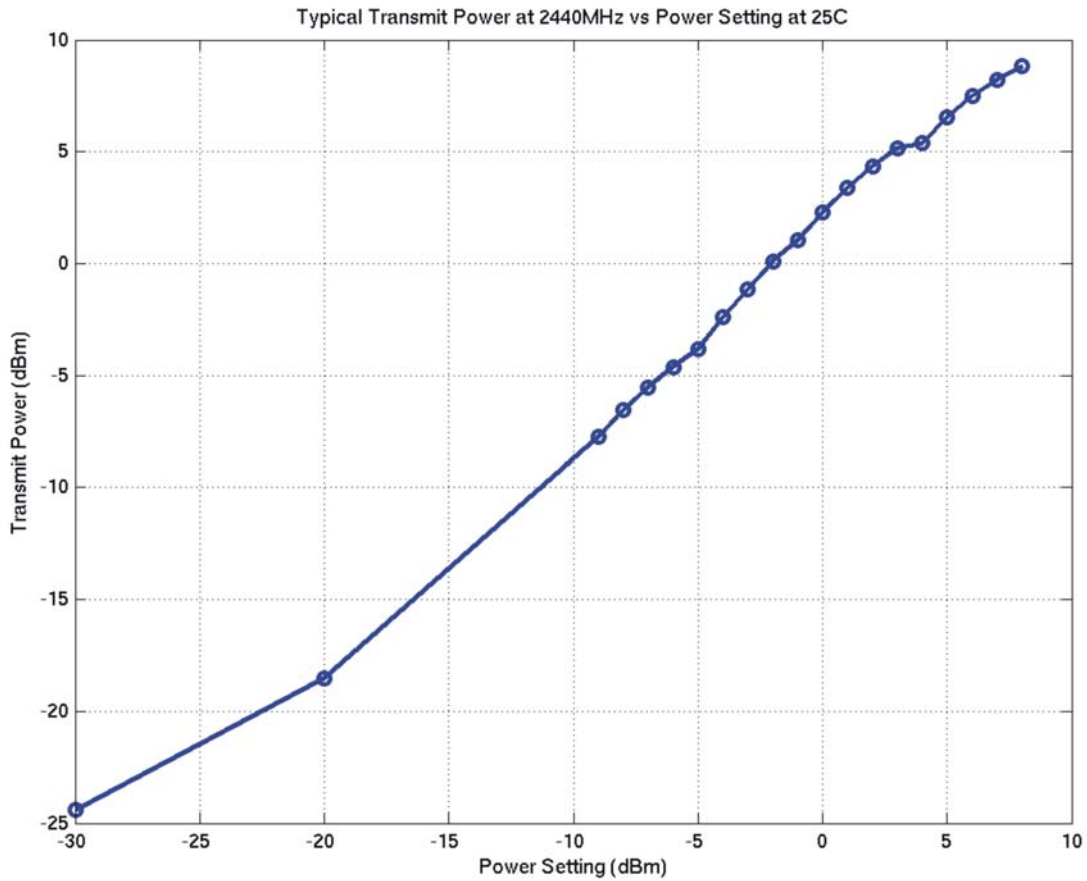

Figure 3: Output Power vs. Power Setting

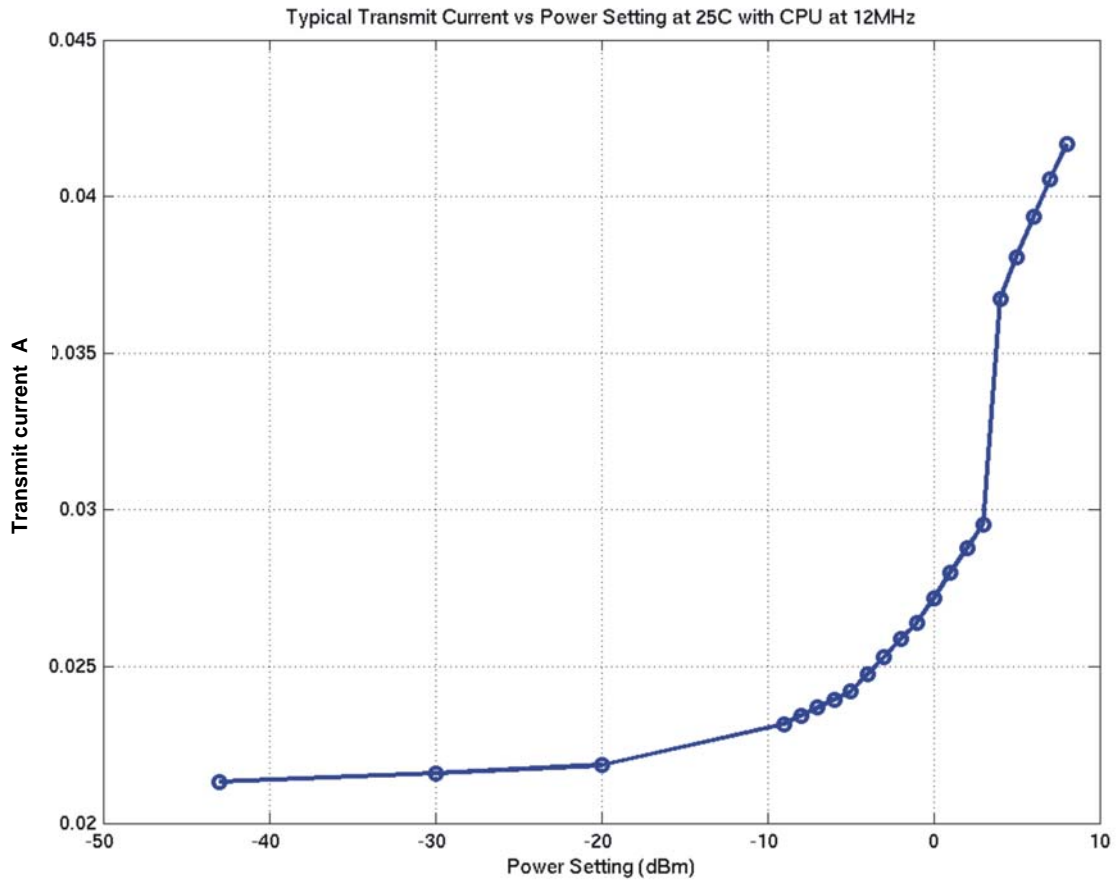

Figure 4: Module Current vs. Power Setting

## 11 Physical Dimensions

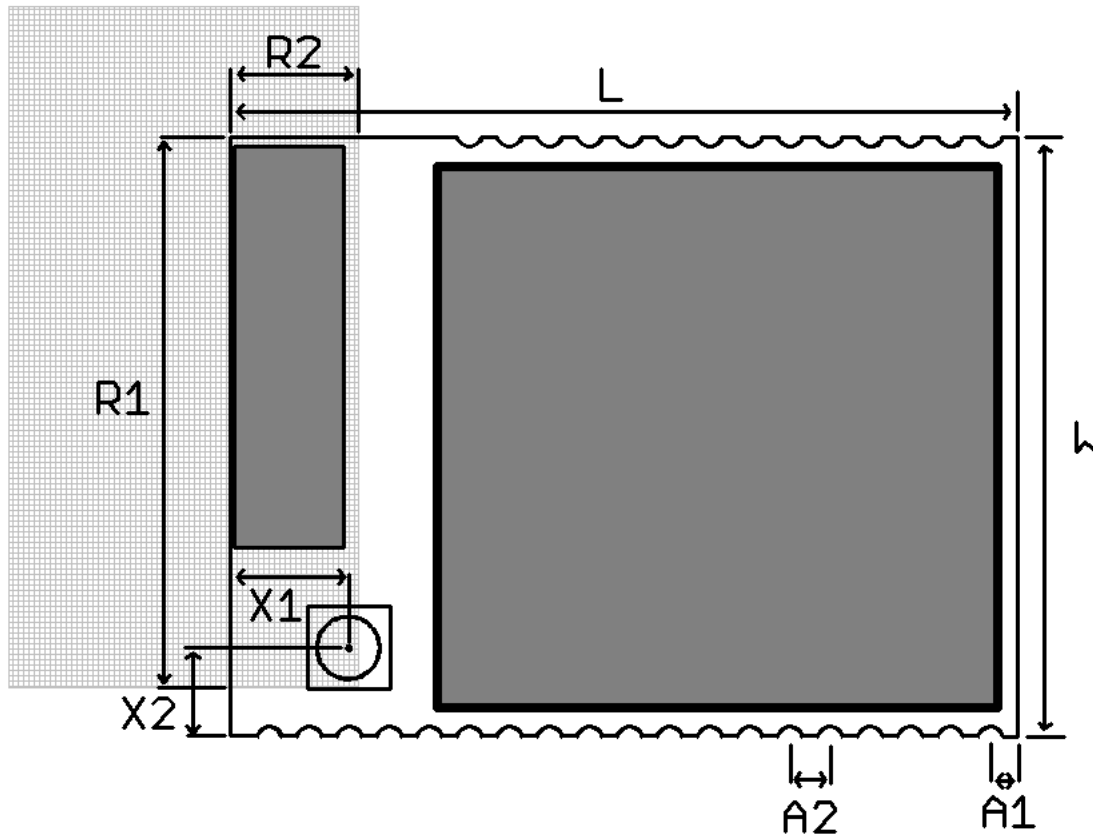

Figure 5: ETRX3 Physical Dimensions

Symbol	Explanation	Typical Distance
L	Length of the module	25.0mm
W	Width of the module	19.0mm
H	Height of the module	3.8mm
A1	Distance centre of pad PCB edge	0.9mm
A2	Pitch	1.27mm
R1	Keep-out Zone from corner of PCB	17.5mm
R2	Keep-out Zone from corner of PCB	4.1mm
X1	Distance centre of Antenna connector PCB edge	3.8mm
X2	Distance centre of Antenna connector PCB edge	2.8mm

Table 14: ETRX3 Physical Dimensions

For ideal RF performance when using the on-board antenna, the antenna should be located at the corner of the carrier PCB. There should be no components, tracks or copper planes in the keep-out area which should be as large as possible. When using the U.FL RF connector the keep-out area does not have to be obeyed. **Note:** The modules' transmit/receive range will depend on the antenna used and also the housing of the finished product.

## 12 Soldering Temperature Profile (for reflow soldering)

### 12.1 For Leaded Solder

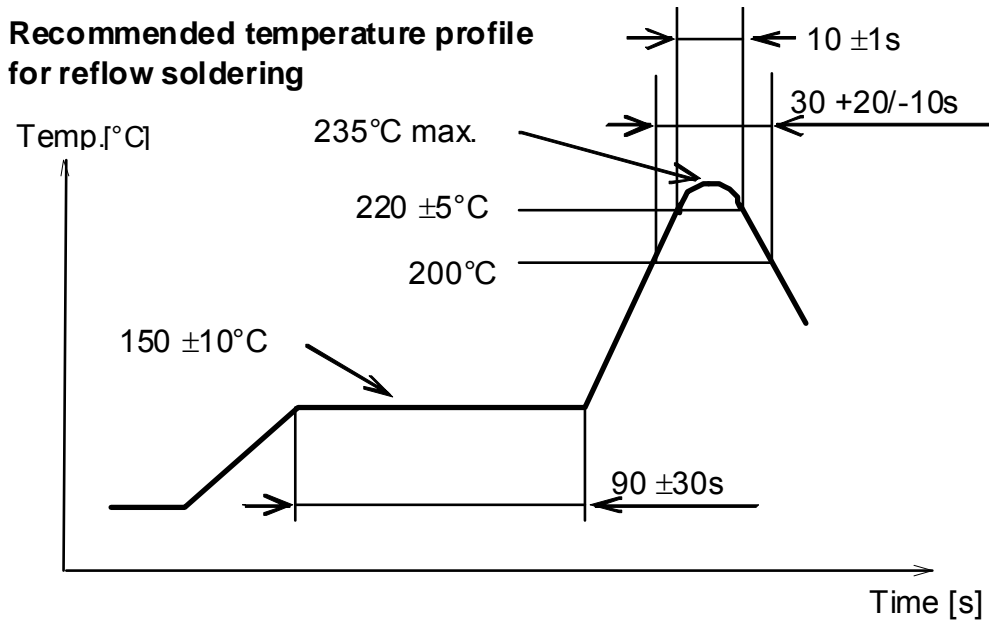

Figure 6: Temperature Profile for Leaded Solder

### 12.2 For Lead-free Solder

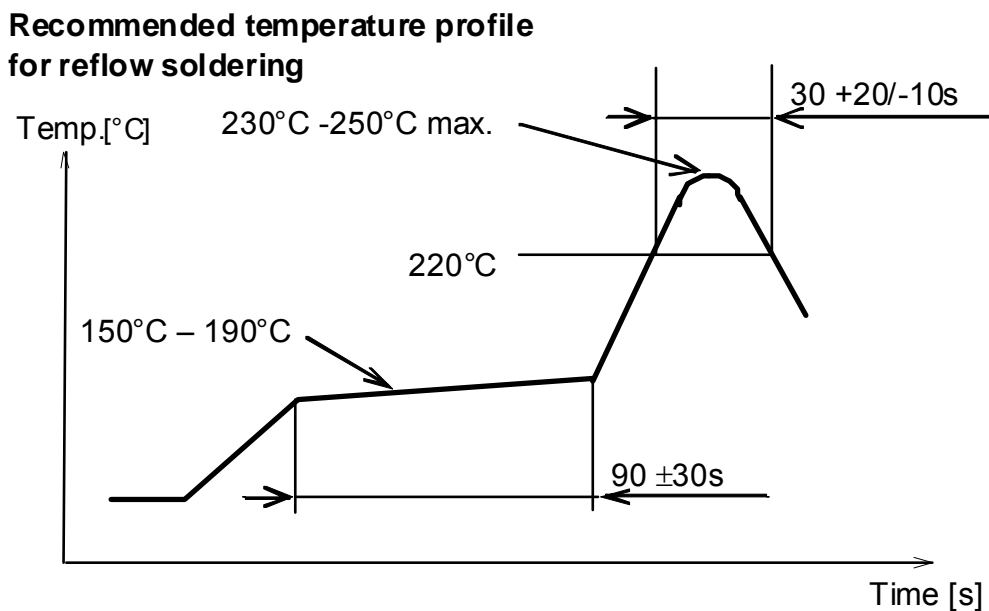

Figure 7: Temperature Profile for Lead-free Solder

**Please Note:**

**Maximum number of reflow cycles: 2**

**Opposite-side reflow is prohibited due to the module's weight. (i.e. you must not place the module on the bottom / underside of your pcb and re-flow).**

### 13 Product Label Drawing



Figure 8: Product Label

The label dimensions are 14.0mm x 14.0 mm. The label will withstand temperatures and chemicals used during a typical manufacturing process.

Example imprint	Description
ETRX357HR	Module Order code
000001	Indication for the serial number.
090101	Production Date Code in the format YYMMDD, e.g. 090602
01	Indication for batch number
02	Indication for the hardware revision
FCC ID: S4GEM35XA	FCC ID code for this product
2D-Barcode	Information in the Datamatrix 2D-Barcode are the serial number [6 characters], the Part-Order code [12 characters], identifier for the batch number [2 characters], the identifier for the hardware release [2 characters] and the production date code in the format Year-Month-Day [6 characters], separated by a semicolon.

Table 15: ETRX3xx Label Details

## 14 Recommended Footprint

In order to surface mount an ETRX3 series module, we recommend that you use pads which are 1mm wide and 1.2mm high. You must retain the keep-out zone shown in section 12, and ensure that this keep-out area is free of components, copper tracks and/or copper planes/layers.

You must also ensure that there is no exposed copper on your layout which may contact with the underside of the ETRX3 series module.

For best RF performance it is required to provide good ground connections to the ground pads of the module. It is recommended to use multiple vias between each ground pad and a solid ground plane to minimize inductance in the ground path.

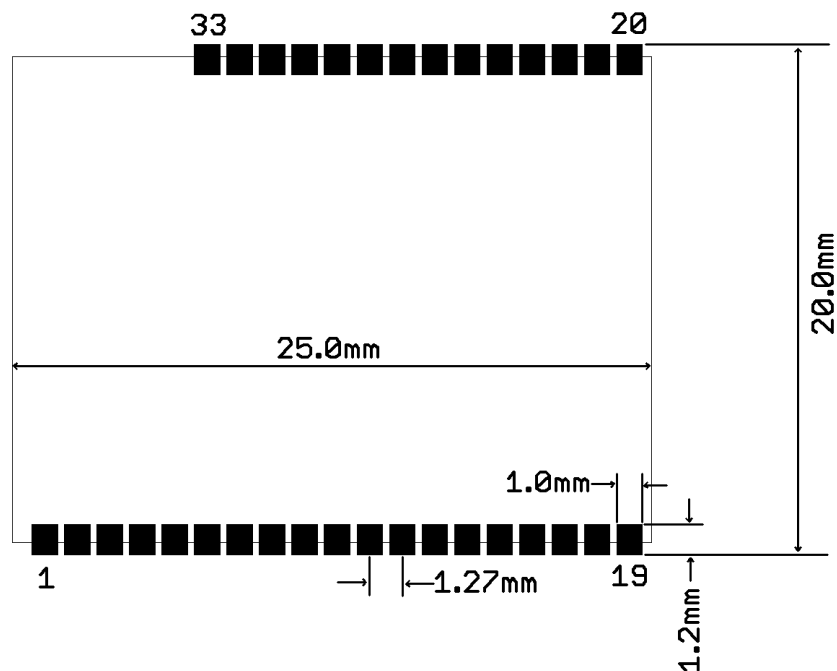

Figure 9: Recommended Footprint

The land pattern dimensions above serve as a guideline.

We recommend that you use the same pad dimensions for the solder paste screen as you have for the copper pads. However these sizes and shapes may need to be varied depending on your soldering processes and your individual production standards. We recommend a paste screen thickness of 120µm to 150µm.

Although the undersides of the ETRX3 series modules are fully coated, no exposed copper, such as uncovered through-hole vias, planes or tracks on your board component layer, should be located below the ETRX3 series module in order to avoid 'shorts'. All ETRX3 series modules use a multilayer PCB containing an inner RF shielding ground plane, therefore there is no need to have an additional copper plane directly under the ETRX3 series module.

### 14.1 Example carrier board

Since the RF performance of the module with the on board antenna is strongly dependent on the proper location of the module on its carrier board, Figure 10 shows the reference carrier board which was used during testing by Telegesis.

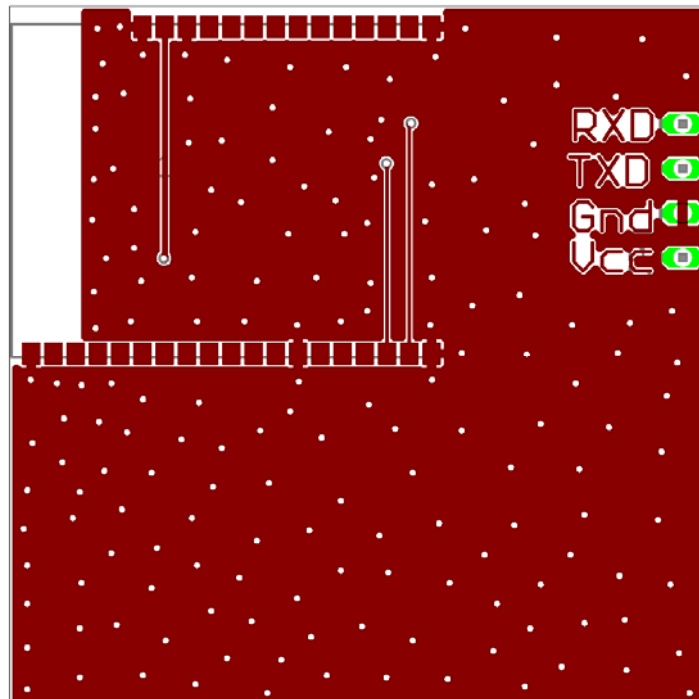

Figure 10. Reference Board

For best performance it is recommended to locate the antenna towards the corner of the carrier board and to respect the recommended keep-out areas as described in section 11.

Finally to provide a good reference ground to the on board antenna, the carrier board should have a ground plane spanning no less than 40 x 40mm. In many cases a smaller ground plane will suffice, but degradation in radio performance could be the result.

## 15 Reliability Tests

The measurements below have been conducted on random samples out of mass production and passed after the module has been exposed to standard room temperature and humidity for 1 hour.

No	Item	Limit	Condition
1	Vibration test	Electrical parameter should be in specification	a) Freq.:10~50Hz,Amplitude:1.5mm a) 20min. / cycle,1hrs. each of XYZ axis b) Freq.:30~100Hz, 6G b) 20min. / cycle,1hrs. each of XYZ axis
2	Shock test	the same as the above	Dropped onto hard wood from height of 50cm for 3 times
3	Heat cycle test	the same as the above	-40°C for 30min. and +85°C for 30min.; each temperature 300 cycles
4	Moisture test	the same as the above	+60°C, 90% RH, 300h
5	Low temp. test	the same as the above	-40°C, 300h
6	High temp. test	the same as the above	+85°C, 300h

**Table 16: Reliability Tests**

## 16 Application Notes

### 16.1 Safety Precautions

These specifications are intended to preserve the quality assurance of products as individual components.

Before use, check and evaluate the module's operation when mounted on your products. Abide by these specifications when using the products. These products may short-circuit. If electrical shocks, smoke, fire, and/or accidents involving human life are anticipated when a short circuit occurs, then provide the following failsafe functions as a minimum:

- (1) Ensure the safety of the whole system by installing a protection circuit and a protection device.
- (2) Ensure the safety of the whole system by installing a redundant circuit or another system to prevent a single fault causing an unsafe status.

### 16.2 Design Engineering Notes

- (1) Heat is the major cause of shortening the life of the modules. Avoid assembly and use of the target equipment in conditions where the product's temperature may exceed the maximum allowable.
- (2) Failure to do so may result in degrading of the product's functions and damage to the product.
- (3) If pulses or other transient loads (a large load applied in a short time) are applied to the products, before use, check and evaluate their operation when assembled onto your products.
- (4) These products are not intended for other uses, other than under the special conditions shown below. Before using these products under such special conditions, check their

performance and reliability under the said special conditions carefully, to determine whether or not they can be used in such a manner.

- (5) In liquid, such as water, salt water, oil, alkali, or organic solvent, or in places where liquid may splash.
- (6) In direct sunlight, outdoors, or in a dusty environment
- (7) In an environment where condensation occurs.
- (8) In an environment with a high concentration of harmful gas (e.g. salty air, HCl, Cl<sub>2</sub>, SO<sub>2</sub>, H<sub>2</sub>S, NH<sub>3</sub>, and NO<sub>x</sub>)
- (9) If an abnormal voltage is applied due to a problem occurring in other components or circuits, replace these products with new products because they may not be able to provide normal performance even if their electronic characteristics and appearances appear satisfactory.
- (10) Mechanical stress during assembly of the board and operation has to be avoided.
- (11) Pressing on parts of the metal cover or fastening objects to the metal cover is not permitted.

### 16.3 Storage Conditions

- (1) The module must not be stressed mechanically during storage.
- (2) Do not store these products in the following conditions or the performance characteristics of the product, such as RF performance, may well be adversely affected:
  - (3) Storage in salty air or in an environment with a high concentration of corrosive gas, such as Cl<sub>2</sub>, H<sub>2</sub>S, NH<sub>3</sub>, SO<sub>2</sub>, or NO<sub>x</sub>
  - (4) Storage in direct sunlight
  - (5) Storage in an environment where the temperature may be outside the range of 5°C to 35°C range, or where the humidity may be outside the 45 to 85% range.
  - (6) Storage (before assembly of the end product) of the modules for more than one year after the date of delivery at your company even if all the above conditions (1) to (3) have been met, should be avoided.

## 17 Packaging

### 17.1 Embossed Tape

- (1) Dimension of the tape  
t.b.d.

- (2) Cover tape peel force

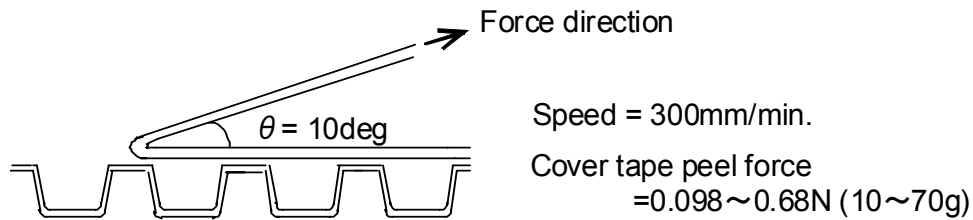

- (3) Empty pockets

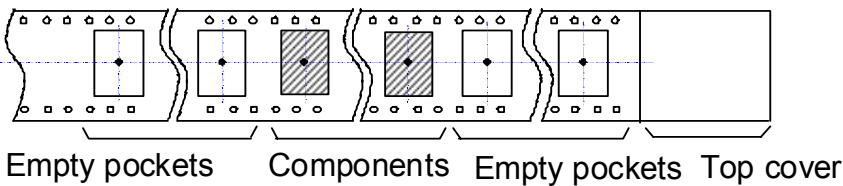

**NB:** Empty pockets in the populated area will be less than two per reel and those empty pockets will not be consecutive.

**17.2 Component Orientation**

Top cover tape will not obstruct the carrier tape holes and will not extend beyond the edges of the carrier tape

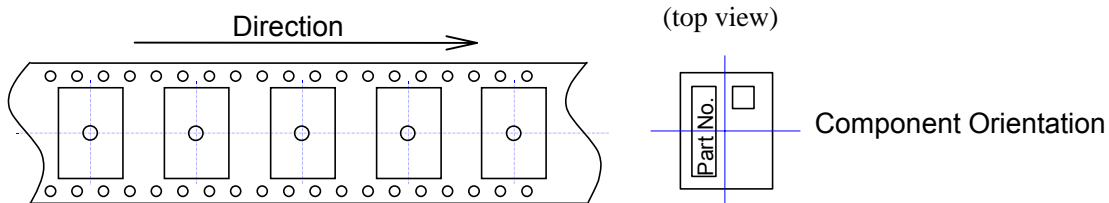

**17.3 Reel Dimensions**

- (4) Quantity per reel: 600 pieces
- (5) Marking: Part No. / Quantity / Lot No. and manufacturer part# with bar-code will be on the reel

t.b.d.

**17.4 Packaging**

- (6) Each reel will be packed in a hermetically-sealed bag
- (7) Marking: Part No. / Quantity / Lot No. and manufacturer part# with bar-code

## 18 Ordering Information

Ordering/Product Code	Description
<b>ETRX351</b> <b>ETRX357</b>	Telegesis Wireless Mesh Networking Module with Ember ZigBee® Technology: <ul style="list-style-type: none"> <li>• Based on Ember EM351 or EM357</li> <li>• Telegesis AT Style Command Interpreter based on</li> <li>• EmberZNet meshing and self-healing ZigBee® PRO stack</li> <li>• Integrated 2.4GHz Antenna</li> </ul>
<b>ETRX351HR</b> <b>ETRX357HR</b>	Telegesis Wireless Mesh Networking Module with Ember ZigBee® Technology: <ul style="list-style-type: none"> <li>• Based on Ember EM351 or EM357</li> <li>• Telegesis AT Style Command Interpreter based on</li> <li>• EmberZNet meshing and self-healing ZigBee® PRO stack</li> <li>• U.FL coaxial Antenna Connector</li> </ul>
<b>ETRX3DVK</b>	Telegesis Development Kit with: <ul style="list-style-type: none"> <li>• 3 x ETRX35xDV Development Boards</li> <li>• 3 x USB cables</li> <li>• 2 x ETRX35x on carrier boards</li> <li>• 2 x ETRX35xHR on carrier boards</li> <li>• 2 x ETRX35x-LR on carrier boards</li> <li>• 2 x ETRX35xHR-LR on carrier boards</li> <li>• 1 x ETRX2USB USB stick</li> <li>• 2 x ½-wave antennae</li> <li>• 2 x ¼-wave antennae</li> </ul>

**Notes:**

- Customers' PO's must state the Ordering/Product Code.
- There is no "blank" version of the ETRX35x modules available. All Modules are pre-programmed with the Telegesis AT style command interpreter based on the EmberZNet stack. (In case it is desired to program custom firmware the pre-programmed firmware can simply be overwritten).

## 19 Disclaimer

Product and company names and logos referenced may either be trademarks or registered trademarks of their respective companies. We reserve the right to make modifications and/or improvements without prior notification. All information is correct at time of issue. Telegesis (UK) Ltd does not convey any license under its patent rights or assume any responsibility for the use of the described product

## 20 RoHS Declaration

Declaration of environmental compatibility for supplied products:

Hereby we declare based on the declaration of our suppliers that this product does not contain the following substances which are banned by Directive 2002/95/EC (RoHS) or if they do, contain a maximum concentration of 0,1% by weight in homogeneous materials for:

- Lead and lead compounds
- Mercury and mercury compounds
- Chromium (VI)
- PBB (polybrominated biphenyl) category
- PBDE (polybrominated biphenyl ether) category

And a maximum concentration of 0.01% by weight in homogeneous materials for:

- Cadmium and cadmium compounds

## 21 Data Sheet Status

Telegesis (UK) Ltd. reserves the right to change the specification without notice, in order to improve the design and supply the best possible product. Please consult the most recently issued data sheet before initiating or completing a design.

## 22 Life Support Policy

This product is not designed for use in life support appliances, devices, or systems where malfunction can reasonably be expected to result in a significant personal injury to the user, or as a critical component in any life support device or system whose failure to perform can be reasonably expected to cause the failure of the life support device or system, or to affect its safety or effectiveness. Customers using or selling these products for use in such applications do so at their own risk and agree to fully indemnify Telegesis (UK) Ltd. for any damages resulting.

## 23 Related Documents

- [1] IEEE Standard 802.15.4 –2003 Wireless Medium Access Control (MAC) and Physical Layer (PHY) Specifications for Low-Rate Wireless Personal Area Networks (LR-WPANS)
- [2] Datasheet EM35x, Ember. ([www.ember.com](http://www.ember.com))
- [3] Datasheet U.FL-Series 2004.2 Hirose Ultra Small Surface Mount Coaxial Connectors - Low Profile 1.9mm or 2.4mm Mated Height
- [4] The ZigBee® specification ([www.zigbee.org](http://www.zigbee.org))
- [5] Specification for Antenova Rufa Antenna ([www.antenova.com](http://www.antenova.com))
- [6] Embedded Antenna design Ltd. (EAD Ltd.) ([www.ead-ltd.com](http://www.ead-ltd.com))
- [7] Wellhope Communication Equipment ([www.wellhope-wireless.com](http://www.wellhope-wireless.com))

## 24 Contact Information

Website: [www.telegesis.com](http://www.telegesis.com)  
E-mail: [sales@telegesis.com](mailto:sales@telegesis.com)

Telegesis (UK) Limited  
Abbey Barn Business Centre  
Abbey Barn Lane  
High Wycombe  
Bucks  
HP10 9QQ  
UK

Tel: +44 (0)1494 510199

Fax: +44 (0)5603 436999