



TM2 GSM/GPRS module User Manual



User Manual

TM2 GSM/GPRS Module

History

Company was established on 15th of April 1998. Main residence is based in Vilnius.

Company started with production of telecommunication devices.

In 2001 company expanded its fields of activity by starting design and manufacturing of electrical systems for wireless data transfer.

In 2002 contract of partnership and collaboration was signed with company Pro-Sign GmbH (Germany), considering design and representation of graphic programming interface iCon-L in Eastern Europe.

In 2003 Teltonika and NOKIA became partners and started integration of NOKIA M2M technology using NOKIA N12 module. It was the beginning of wireless technology development process.

In 2004, NOKIA invited Teltonika to join presentation of M2M technology innovations in CeBIT 2004. It was very high evaluation of a small Lithuanian company and its possibilities, which helped to feel peculiarities of international business.

In 2004 Teltonika produced more than 10 new products and solutions using EDGE technology. It was a condition that made Teltonika a leader of M2M integration solutions using EDGE not only in Lithuania, but also in Europe.

2005 was the year of two successful international exhibitions: CEBIT 2005 and HANNOVER MESSE 2005. These shows opened new possibilities for offering our products and solutions for all world.

In the year 2005 Teltonika became an international company. We became Lithuanian - Finnish Company. A few employees from NOKIA joined Teltonika's staff. Presently they successfully develop activity of new companies: Teltonika International GmbH (Düsseldorf) and Teltonika International Oy (Helsinki).

About US

Our vision is to provide added value for people and companies by creating electrical devices and solutions, which are based on the latest achievements of science and technology.

We aim to help people to integrate the latest technologies in real life, what would bring more cosiness, comfort, freedom of mobility and security to their everyday life.

We seek to make all our solutions an inconceivable part of people lives.

Table of Contents

1 Document Mission	3
1.1 Glossary	3
1.2 Scope of Product	5
1.3 Power Management	5
1.4 Interface	6
1.5 Miscellaneous features	6
2 Product functions	7
2.1 System Features	7
2.2 Modem	10
2.2.1 Mechanical characteristics	11
2.2.2 Power supply	11
2.2.2.1 Current consumptions	12
2.2.2.2 Power Saving	14
2.2.3 GSM/GPRS modem functionalities	15
2.2.4 Supplementary services	16
2.2.5 Short Message Service	16
2.2.6 SIM Functionality	16
2.2.7 AT-command support	16
2.2.8 Other basic features	16
3 User Interfaces	18
3.1 SIM Interface	20
3.2 Battery	21
3.3 Antenna interface	21
3.4 Asynchronous Serial interface	22
3.5 GPIO	22
3.6 SW interfaces	23
3.7 Audio devices	28
3.7.1 Handset	28
3.7.2 Headset	28
3.7.3 Microphone	28
3.7.4 Hands-free	28
3.7.5 Polyphonic ringer	28
3.7.6 ADC interface / Measurement interface	29
3.7.7 SPI	29
3.7.8 I2C bus interface	29

1 Document Mission

The TM2 User Manual provides all information necessary for a successful integration of TM2 module into the application of the customer. Additionally, TM2 User Manual contains all product functions for application.

1.1 Glossary

Abbreviation / Term	Explanation / Definition
ADC	Analog-to-Digital Converter
ADN	Abbreviated Dialling Numbers
AFC	Automatic Frequency Correction
AND	Abbreviated Dialing Number
AMR	Adaptive Multi Rate
API	Application Programming Interface
ASC	Asynchronous Serial Interface Controller
BCCH	Broadcast Control Channel
BDN	Barred Dialing Number
CB	Cell Broadcast
CBCH	Cell Broadcast Channel
CCCH	Common Control Channel
CD	Carrier Detect
CGU	Clock Generation Unit
CLI	Calling Line Identification
CSD	Circuit Switched Data
DAI	Digital Audio Interface
DCE	Data Communication Equipment
DCS	Digital Cellular System (1800 MHz)
DCXO	Digital Controlled Crystal Oscillator
DL	Reception
DSP	Digital Signal Processor
DSR	Data Set Ready
DTE	Data Terminal Equipment
DTMF	Dual Tone Multi Frequency
DTR	Data Transmit Receive
EBU	External Bus Interface Unit
EFR	Enhanced Full Rate
EGSM	Extended - Global System for Mobile Communication

EMS	Enhanced Messaging Service
ESD	Electro Static Discharge
ETSI	European Telecommunications Standards Institute
FDN	Fixed Dialing Number
FFS	Flash File System
FR	Full Rate
GPIO	General Purpose Input/Output
GPP	3rd Generation Partnership Project
GPRS	General Packet Radio System
GSM	Global System for Mobile Communication
HR	Half Rate
HW	Hardware
IC	Integrated Circuit
I2C	Inter-Integrated Circuit
IIR	Infinite Impulsive Response
IMEI	International Mobile Equipment Identity
JTAG	Joint Test Action Group
LDN	Last Dialing Number
M2M	Machine-to-Machine
ME	Mobile Equipment
MIDI	Musical Instrument Digital Interface
MS	Mobile Station
MSC	Multi-Slot Class
N-AMR	Narrow-AMR
NOM	Network Operating Mode
NV	Non Volatile
PA	Power Amplifier
PC	Personal Computer
PBCCH	Packet Broadcast Control Channel
PCCCH	Packet Common Control Channel
PCS	Personal Communication Service
PDP	Packet Data Protocol
PDU	Protocol Data Unit
PLMN	Public Land Mobile Network
PPS	Protocol and Parameter Selection
PST	Protocol Stack
PWM	Pulse Width Modulation
RF	Radio Frequency
RTC	Real Time Clock
RX	Receiver

SAW	Surface Acoustic(al) Wave
SDN	Service Dialing Number
SIM	Subscriber Identity Module
SMA	SubMiniature version A connector
SMS	Short Message Service
SMS MO	Short Message Service Mobile-Originated
SMS MT	Short Message Service Mobile-Terminated
SPMidi	Scalable Polyphony MIDI
SPI	Serial Peripheral Interface
SSC	Serial Synchronous Interface Controller
STK	SIM Toolkit
SW	Software
TCH	Traffic Channel
TX	Transmitter
UART	Universal Asynchronous Receiver-Transmitter
UL	Transmission

1.2 Scope of Product

TM2 is a small, light weight and low power consumption module that enables digital communications services on GSM/GPRS networks for machine to machine or user to machine wireless applications.

TM2 modules are developed in compliance with internal and normative certification requirements. In particular, they are certified by CE approval report and Radio & Tele Terminal Equipment Directive (R&TTE) report. Requirements for lead-free components are imposed and satisfied.

The product implements a quad-band MS able to operate in the frequency bands GSM 850 MHz, EGSM 900 MHz, and DCS 1800 MHz and PCS 1900 MHz; the dynamic behavior can be configured dynamically by disabling/enabling a specific band e.g. through AT commands. Eventually, the module can be configured either dual-band or tri-band or quad-band.

The supported power classes for both voice and data services will be:

- Class 4 (2W) for GSM/EGSM bands.
- Class 1 (1W) for DCS/PCS bands.

The product implements a Class B Mobile Station; this means the data module can be attached to both GPRS and GSM services, using one service at a time. Network operation modes I to III are supported, with user-definable preferred service between GSM and GPRS.

Ignition: it takes around 800 ms to enter in AT active state (eg AT OK, see picture). From this state we have a 2 seconds setup and stabilization time before the startup signal is sent to the m2m applications.

Minimum RESET time safe value is 120 ms

1.3 Power Management

- Battery connector.

1.4 Interface

- SIM card holder supporting 1.8 V and 3 V card type.
- MMCX Interface connector for RF output (50 Ohm connector MMCX Edge Mount SMD J01341A0081 (Telegartner)).
- 60 pin board-to-board connector (CVILUX CBRB060PC2000R0): Audio (2x analog, 1x digital), I2C bus, SPI bus, 2x ADC, 2x analog out (PWM), 12 GPIOs.
- 2 UART serial ports.

1.5 Miscellaneous features

- 40 tones polyphonic ring tones support.

2 Product functions

2.1 System Features

A comprehensive list of TM2's features is presented in the following table and further detailed in the following paragraphs. The features can be shared in the following sections:

- Generic features;
- GSM/GPRS modem functionalities;
- Mechanical and Electronics features;
- Software features;
- Accessory support ;
- Host SW tools.

Set of features	Description
Type approval	CE approval report available
	Radio & Tele Terminal Equipment Directive (R&TTE) report available
Environmental constraints	Requirements for lead-free components
Security	Platform security concept description available
	Secure IMEI management
	Secure flashing environment
	Secure memory area
Service software API functionality	Software update
	Software update using system connector
	Module testing SW
	Rewrite IMEI
	Manage SIM locks
	Backup and restore user data
	Defect logger to analyze memory trace
GSM standard compliancy	ETSI GSM Phase 2+ (R99)
Frequency Bands	GSM 850 MHz
	EGSM 900 MHz
	DCS 1800 MHz
	PCS 1900 MHz
	Disable band/Manual band selection
GSM/GPRS Data Services	GPRS multi-slot class (MSC) 10 (4+1, 3+2)
	GPRS PBCCH/PCCCH support
	CBCH reception when on PBCCH supported
	GPRS Class B and CC
	Coding scheme CS-1, CS-2, CS-3, CS-4
	Network operation mode I, II, III

Set of features	Description
	CSD up to 9.6kbps (V.32, V.110)
	FAX G3, Class 2.0
SMS Short message service	Short Message Service Mobile-Terminated (SMS MT)
	Short Message Service Mobile-Originated (SMS MO)
	SMS-CB Cell Broadcast (SMS CB)
	Concatenated SMS
	Via GSM or GPRS
	Text and PDU mode
SIM Functionality	Abbreviated Dialling Numbers (ADN)
	Fixed Dialling Numbers (FDN)
	Last Dialed Numbers (LDN)
	Service Dialling Numbers (SDN)
	SIM Lock protection
	SIM Toolkit
SIM Locks	Network
	Network subset
	Service provider
	Corporate
	Operator
Basic Mobile Station features	Display of Called Number
	Indication of Call Progress Signals
	Country/PLMN Indication
	Short Message Indication and Acknowledgement
	International Access Function
	Service Indicator
	Dual Tone Multi Frequency (DTMF)
	Subscription Identity Management
	On/Off Switch
	Service Provider Indication
GSM Supplementary services	Call Hold (CH)
	Call Waiting (CW)
	Multi-Party (MTPY)
	Call Forwarding (CF)
	Explicit Call Transfer (ECT)
	Call Barring (CB)
	Calling Line Identification Presentation (CLIP)
	Calling Line Identification Restriction (CLIR)

Set of features	Description
	Connected Line Identification Presentation (COLP)
	Connected Line Identification Restriction (COLR)
	Unstructured Supplementary Services Data (USSD)
Audio Codecs	Speech codecs FR (Full rate) / EFR (Enhanced Full Rate) / HR (Half Rate)
	Speech codecs AMR (Adaptive Multi Rate)
Encryption algorithms	Encryption algorithms A5/1
	Encryption algorithms A5/2
Mechanical features	Number of RF shield required = 1
	Number of PIN's used for SW flashing = 3 (RX/TX and Ground)
Connector	RF connector
	Board to board connector
	SIM holder
RTC	Real Time Clock (RTC) supported with alarm capabilities
SIM	SIM connector on-board or external
	SIM voltage: 1.8 and 3 V
	High-speed interface
	External SIM ESD protection required.
	External SIM connector support
Battery	Protection circuitry integrated on the platform
	Charging of deeply discharged battery must be possible.
	Charging during phone call
	Maximum charging current of battery :1100 mA
Audio features	Handsfree and headset operation
Audio filter types supported	Echo canceller
	Noise reduction
I/O Interfaces	Maximum number of GPIO-interfaces 12
	Number of UART's 2
	Number of free UART's for user : 1
	One UART with complete 9-pin UART 1
	Max speed UART 921.6 Kbps (default AT commands 115.2 kbps)
	One UART with only RX/TX
Power on	Power on time (sec) 3 sec

Set of features	Description
Call Handling	Redial missed and/or received calls (CLI)
	Abbreviated Dialling
Call phone	Full duplex
	Ringtones
	Polyphonic ringtones
Audio formats integrated with the hardware	HR, FR, EFR, AMR
	MIDI 1.0
	iMelody
	Number of simultaneous polyphonic tones (without extra HW) 40
Accessory support	Audio headset
	Charger

2.2 Modem

The modem part provides with minimal component's list all functionality necessary for voice and data transmission over GSM and GPRS network. The modem is divided in two separated areas surrounded by traces on which metal boxes can be soldered. The first area encloses the RF High power components and the remaining passive components of the transceiver; the second area group's baseband processor, memory, crystals and power management unit.

2.2.1 Mechanical characteristics

The Number of RF shield required is 1. For mechanical characteristics of GSM/GPRS module refer to the following:

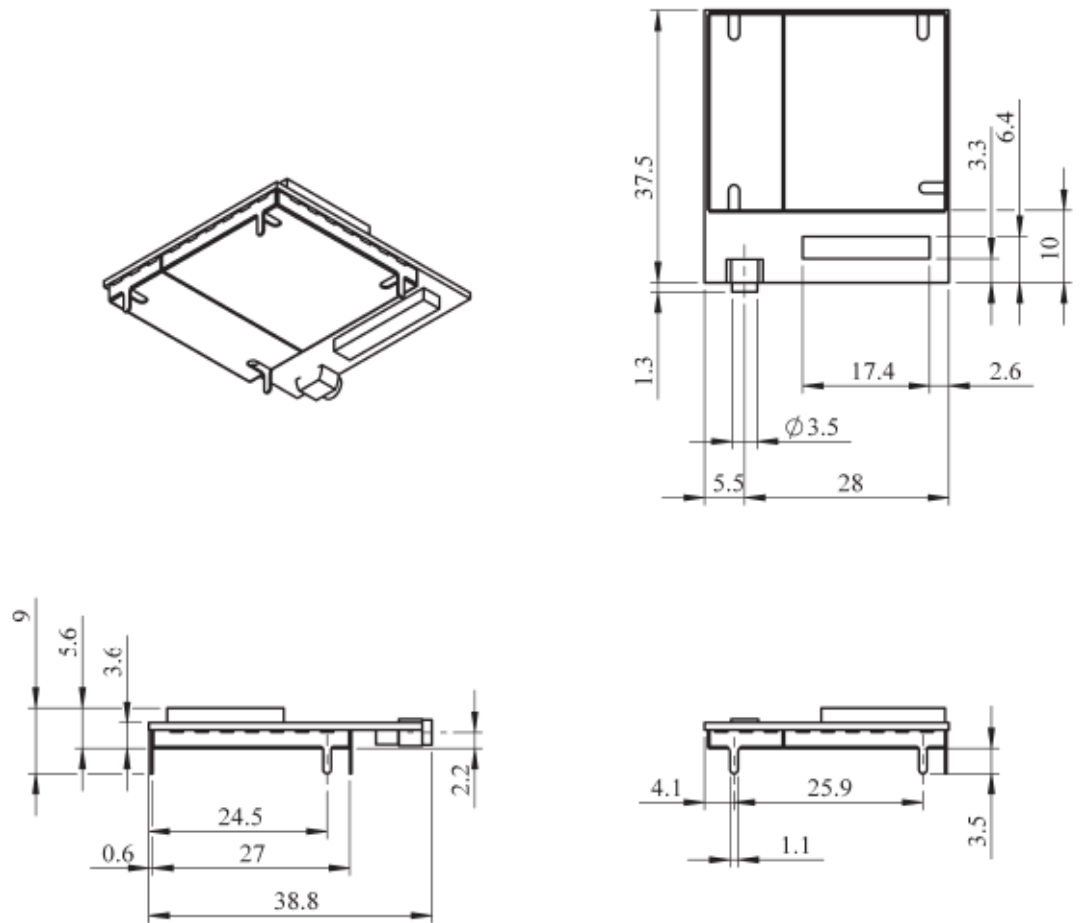

Fig. 2.2.1.1 TM2 Dimensional layout

Mechanical and environment	Value
Size	33.5 mm x 38.8 mm x 5.6 mm
Weight	< 10 g
Operating temperature range	From -20°C to +55°C

2.2.2 Power supply

The on board power supply is derived by CviLux connector that provides a voltage value VBAT on pins 1, 3, 5, 7. The range of VBAT is between 3.5 V and 4.2 V, while typically its value is 3.8 V.

Description	Min	Typ	Max
Supply voltage	3.5 V	3.8 V	4.2 V

2.2.2.1 Current consumptions

Current consumptions of TM2 module are reported in the following pages. Power OFF current is $< 30 \mu\text{A}$.

BAND: GSM900

TEST SETTINGS:

DRX: 5;

BA LIST arfcn: 1 9 17 26 34 42 50 58 67 75 83 91 99 108 116 124;

PCL: 5.

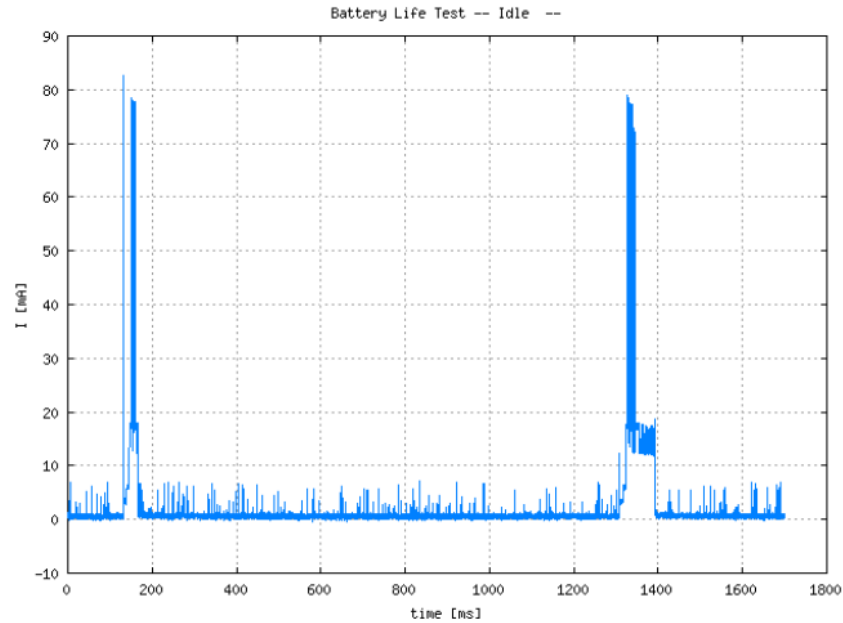

GSM900
Idle mode
Average current:
1.45 mA

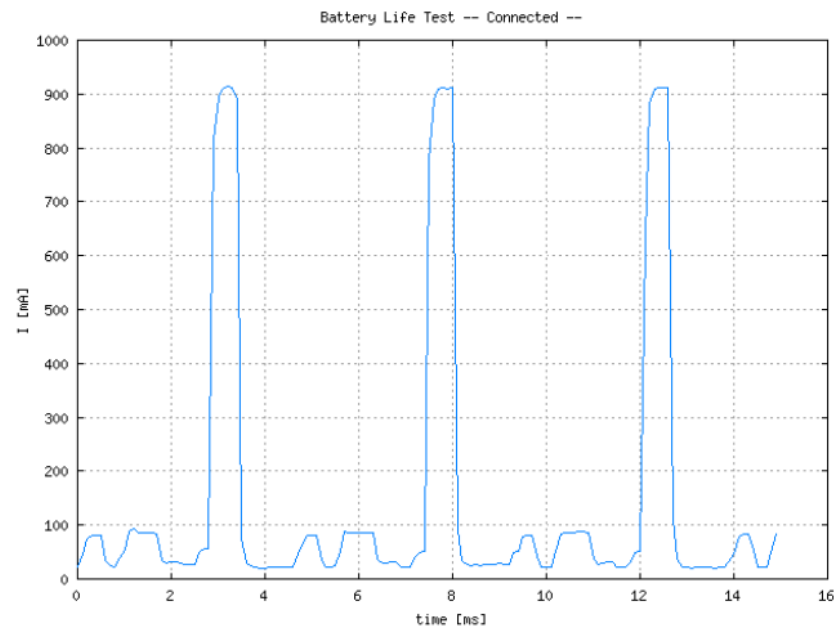

GSM900
Allocated mode
Average current:
147.13 mA

BAND: GSM1800

TEST SETTINGS:

DRX: 5

BA LIST arfcn: 512 530 560 580 610 640 670 700 720 740 760 790 810 840 860

PCL: 0

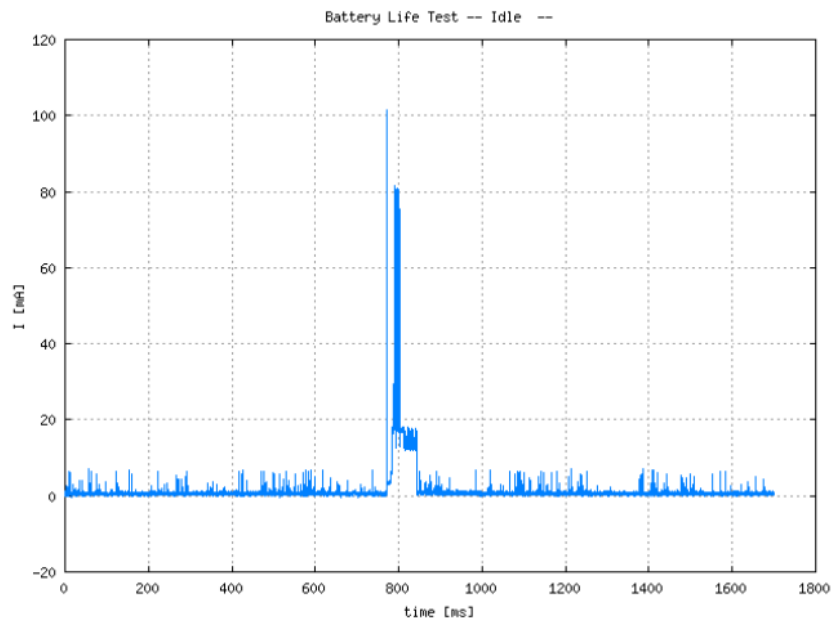

GSM1800
Idle mode
 Average current:
 1.69 mA

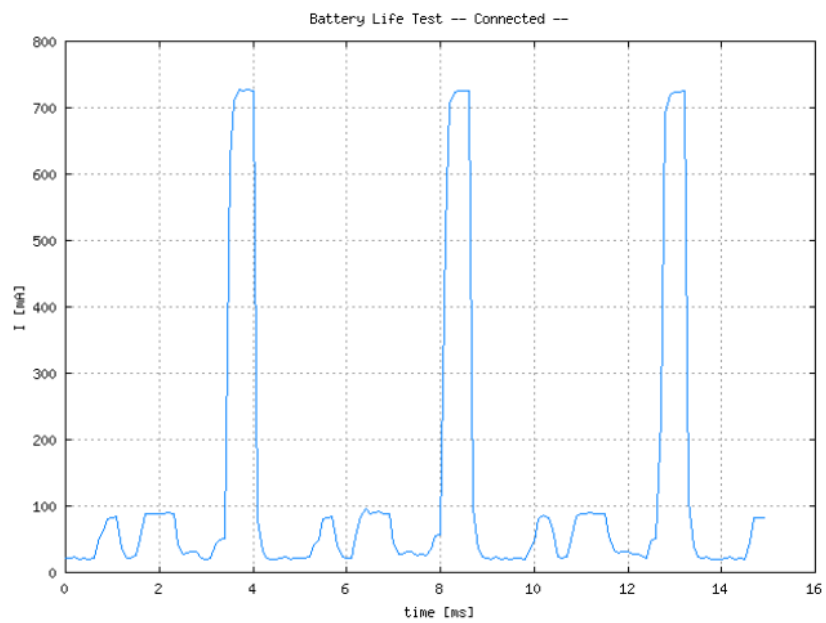

GSM1800
Allocated mode
 Average current:
 127.20 mA

BAND: GSM1900
 TEST SETTINGS:
 DRX: 5
 BA LIST arfcn: 512 530 550 570 590 610 630 650 670 690 710 730 750 770 790
 PCL: 0

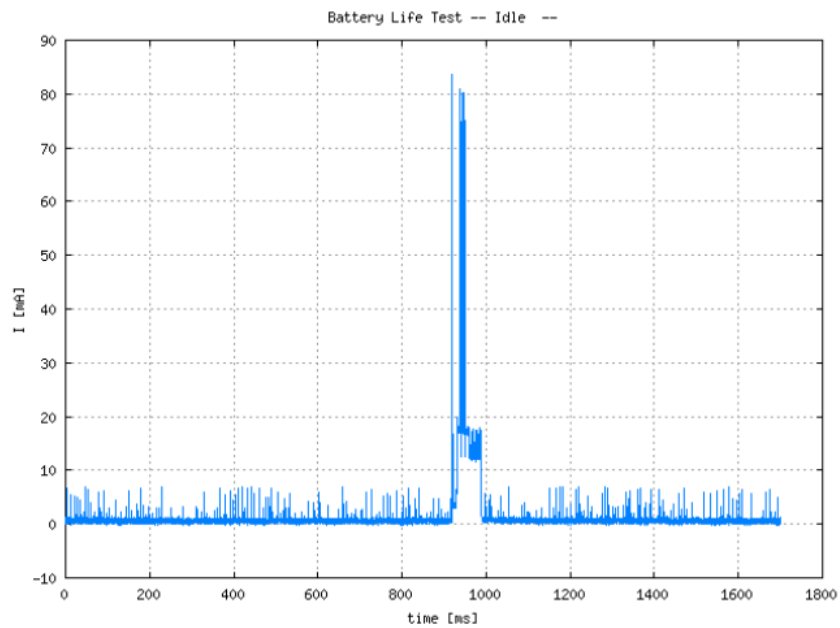

GSM1900
Idle mode
 Average current:
 2.02 mA

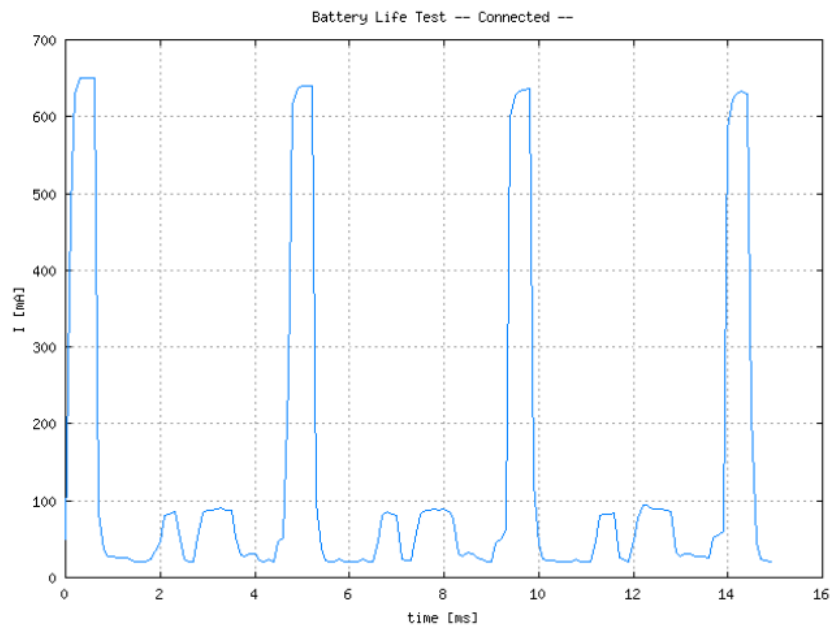

GSM1900
Allocated mode
 Average current:
 113.85 mA

2.2.2.2 Power Saving

Power saving is a special function that allows the reducing of power consumption during the idle time. If the clock increases, required power increases too. Therefore a solution for minimizing the power is the reducing of the master clock frequency when there aren't activities. In this period the system doesn't work with a clock of 26 MHz ("fast clock") but with a clock of 32 KHz (RTC clock or "slow clock"). This switching between 26 MHz and 32 KHz clock is performed by SCCU (Standby Clock Control Unit).

Main priorities of power saving are the following:

1. Reduce base (min) current consumption.
2. Minimize full-speed running periods, minimize power saving on/off switching.
3. Reduce max current consumption.

These points are reported in the following figure:

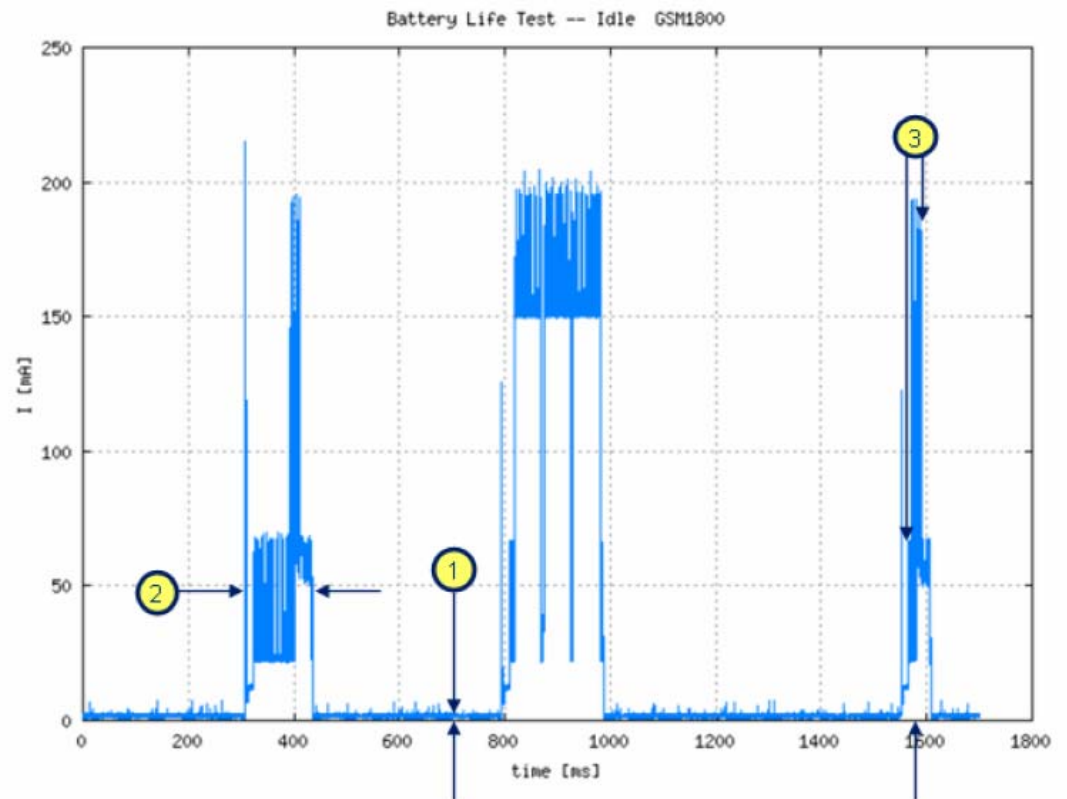

2.2.3 GSM/GPRS modem functionalities

TM2 GSM/GPRS module integrates a full-featured R99 GSM-GPRS Protocol Stack, whose main characteristics are listed in the following. Refer to the Teltonika PICS/PIXIT documentation for a detailed description of the Stack features.

The module can be configured either dual-band or tri-band or quad-band. The product implements a quad-band MS able to operate in the frequency bands GSM 850 MHz, EGSM 900 MHz, DCS 1800 MHz and PCS 1900 MHz; the dynamic behavior can be configured dynamically by disabling/enabling a specific band e.g. through AT commands. The supported power classes for both voice and data services will be:

- Class 4 for GSM band.
- Class 1 for DCS bands.

The product implements a Class B Mobile Station; this means the data module can be attached to both GPRS and GSM services, using one service at a time. Network operation modes I to III are supported, with user-definable preferred service between GSM and GPRS. Optionally paging messages for GSM calls can be monitored during GPRS data transfer in not-coordinating network operation mode NOM II-III. PBCCH/PCCCH logical channels are supported, as well as CBCH reception. GPRS multislot 10 is implemented, implying a maximum of 4 slots in DL (reception) and 2 slots in UL (transmission) and 5 slots on the whole. Finally TM2 GSM/GPRS module supported:

- All coding schemes from CS1 to CS4.
- As for the circuit switched services, speech channel modes HR and FR version 1, 2 and 3 (FR, HR, EFR, N-AMR) are supported.
- Encryption algorithms A5/1 and A5/2 for GSM for GPRS are supported;
- CS Data calls are supported in transparent/non transparent mode up to 9.6 kbps.
- Bearer service fax Group 3 Class 2.0 is supported.

Among access interfaces to DTE, both V.32 and V.110 are provided.

2.2.4 Supplementary services

The following supplementary services are provided:

- Call Hold (CH).
- Call Waiting (CW).
- Multi-Party (MTPY).
- Call Forwarding (CF).
- Explicit Call Transfer (ECT).
- Call Barring (CB).
- Calling Line Identification Presentation (CLIP).
- Calling Line Identification Restriction (CLIR).
- Connected Line Identification Presentation (COLP).
- Connected Line Identification Restriction (COLR).
- Unstructured Supplementary Services Data (USSD).

2.2.5 Short Message Service

Mobile-originated as well as mobile-terminated SMS are supported. Text and PDU mode are supported. Reception of SMS during circuit-switched calls is supported. Reception of SMS via GPRS is also supported. SMS SIM storage is provided.

2.2.6 SIM Functionality

Among SIM functionalities, the following services of the SIM are supported:

- Abbreviated Dialing Numbers (ADN).
- Fixed Dialing Numbers (FDN).
- Last Dialed Numbers (LDN).
- Service Dialing Numbers (SDN).
- ME Personalization (SIM Lock).

ME Personalization handling is a mechanism to tie the ME operation to one specific SIM card or to a limited range of SIM cards from a given Network Operator or Service Provider. The ME will only accept the SIM if there is a positive match between the personalization code group(s) stored in the ME and the code group(s) belonging to the inserted SIM. The SIM Lock feature supported by TM2 GSM/GPRS module enables ME personalization through the following personalization categories:

- Network lock.
- Network subset lock.
- Service provider lock.
- Corporate lock.
- Operator lock.

SIM Toolkit R 99 is supported. For a detailed description of the STK features, refer to the PICS/PIXIT documentation.

2.2.7 AT-command support

The modem functionalities and services are provided through a rich serial AT-command interface. All supported standard as well as proprietary AT commands are detailed in the table of SW interface.

2.2.8 Other basic features

Within the scope of the M2M or user interface, the following indications and functionalities are supported:

- Display of Called Number.
- Indication of Call Progress Signals.

- Country/PLMN Indication.
- Short Message Indication and Acknowledgement.
- International Access Function.
- Service Indicator.
- Dual Tone Multi Frequency (DTMF).
- Subscription Identity Management.
- Service Provider Indication.
- Abbreviated Dialing.
- Power on (external input).

3 User Interfaces

PIN OUT description A 60-pin connector is provided to interface of TM2 module for the power supply, SIM interface, audio interface (2 x analog, 1x digital), I2C bus, SPI bus, 2 x analog in (ADC), 2 x analog out (PWM), 2 UART serial ports, and 12 GPIOs (maximum number).

3.1 Table Pin Out Description

PIN	Name	I/O	Function	I/O type	Description
1	VBAT	PWR	GSM Power Supply	From 3.3 to 4.3 V (Typ: 3.8 V)	Should be connected with pins 3, 5, 7
2	GND	PWR	GSM Power Supply	Ground	Should be connected with pins 4, 6, 8
3	VBAT	PWR	GSM Power Supply	From 3.3 to 4.3 V (Typ: 3.8 V)	Should be connected with pins 1, 5, 7
4	GND	PWR	GSM Power Supply	Ground	Should be connected with pins 2, 6, 8
5	VBAT	PWR	GSM Power Supply	From 3.3 to 4.3 V (Typ: 3.8 V)	Should be connected with pins 1, 3, 7
6	GND	PWR	GSM Power Supply	Ground	Should be connected with pins 2, 4, 8
7	VBAT	PWR	GSM Power Supply	From 3.3 to 4.3 V (Typ: 3.8 V)	Should be connected with pins 1, 3, 5
8	GND	PWR	GSM Power Supply	Ground	Should be connected with pins 2, 4, 6
9	VCHARGE	PWR	GSM Power Supply	0 - 12V (Typ: 6V) Current limited to 600 mA	Should be connected with pin 11
10	DCD	O	Asynchronous Serial Interface 0	CMOS 3.3V compatible	Data Carrier Detect
11	VCHARGE	PWR	GSM Power Supply	0 - 12V (Typ: 6V) Current limited to 600 mA	Should be connected with pin 9
12	DTR	I	Asynchronous Serial Interface 0	CMOS 3.3V compatible	Data Terminal Ready
13	SIM_VCC	I/O	SIM interface	Supply 1.8V-3.3V	SIM power supply
14	CTS_0	I	Asynchronous Serial Interface 0	CMOS 3.3V compatible	Clear To Send
15	SIM_IO	I/O	SIM interface	CMOS 3.3V compatible	SIM I/O serial data
16	RTS_0	O	Asynchronous Serial Interface 0	CMOS 3.3V compatible	Request to Send
17	SIM_CLK	O	SIM interface	CMOS 3.3V compatible	SIM clock signal
18	RXD_0	I	Asynchronous Serial Interface 0	CMOS 3.3V compatible	Receive Serial Data
19	SIM_RST	O	SIM interface	CMOS 3.3V compatible	SIM reset signal
20	TXD_0	O	Asynchronous Serial Interface 0	CMOS 3.3V compatible	Transmit Serial Data
21	MRST0/GPIO	I/O	Synchronous Serial Interface (SPI compatible)	CMOS 3.3V compatible	Master Receive Slave Transmit
22	RI	O	Asynchronous Serial Interface 0	CMOS 3.3V compatible	Ring Indicator

23	MTSR0/GPIO	I/O	Synchronous Serial Interface (SPI compatible)	CMOS 3.3V compatible	Master Transmit Slave Receive
24	DSR	O	Asynchronous Serial Interface 0	CMOS 3.3V compatible	Data Set Ready
25	SCLK0/GPIO	I/O	Synchronous Serial Interface (SPI compatible)	CMOS 3.3V compatible	Shift Clock
26	RXD_1	I	Asynchronous Serial Interface 1	CMOS 3.3V compatible	Receive Serial Data
27	SCL/GPIO	O	I2C bus interface	CMOS 3.3V compatible	Serial Clock Line
28	TXD_1	O	Asynchronous Serial Interface 1	CMOS 3.3V compatible	Transmit Serial Data
29	SDA/GPIO	I/O	I2C bus interface	CMOS 3.3V compatible	Serial Data Line
30	KEYOUT0/GPIO	I/O	Keypad interface / GPIO	CMOS 3.3V compatible	Keypad output pin 0 / GPIO 00
31	CLK0_DAI/GPIO	I/O	Digital Audio Interface	CMOS 3.3V compatible	DAI Clock
32	KEYOUT1/GPIO	I/O	Keypad interface / GPIO	CMOS 3.3V compatible	Keypad output pin 1 / GPIO 50
33	RXD_DAI/GPIO	I	Digital Audio Interface	CMOS 3.3V compatible	DAI Receive
34	KEYOUT2/GPIO	I/O	Keypad interface / GPIO	CMOS 3.3V compatible	Keypad output pin 2 / GPIO 01
35	TXD_DAI/GPIO	O	Digital Audio Interface	CMOS 3.3V compatible	DAI Transmit
36	KEYOUT3/GPIO	I/O	Keypad interface / GPIO	CMOS 3.3V compatible	Keypad output pin 3 / GPIO 02
37	WA0_DAI/GPIO	I/O	Digital Audio Interface	CMOS 3.3V compatible	DAI Reset
38	KEYOUT4/GPIO	I/O	Keypad interface / GPIO	CMOS 3.3V compatible	Keypad output pin 4 / GPIO 03
39	EXTRSTn	I	External reset	CMOS 3.3V compatible	External HW reset
40	KEYOUT5/GPIO	I/O	Keypad interface / GPIO	CMOS 3.3V compatible	Keypad output pin 5 / GPIO 04
41	MICP1	I	Audio Interface	Analog	Handset microphone reference
42	KEYIN0/GPIO	I/O	Keypad interface / GPIO	CMOS 3.3V compatible	Keypad input pin 0 / GPIO 05
43	MICN1	I	Audio Interface	Analog	Handset microphone bias
44	KEYIN1/GPIO	I/O	Keypad interface / GPIO	CMOS 3.3V compatible	Keypad input pin 1 / GPIO 06
45	EPPA1B	O	Audio Interface	Analog	Balanced audio out
46	KEYIN2/ON	I/O	Keypad interface / Power on	CMOS 3.3V compatible	Keypad input pin 2 / Power on button / GPIO 07
47	EPPA2A	O	Audio Interface	Analog	Balanced audio out
48	KEYIN3/GPIO	I/O	Keypad interface / GPIO	CMOS 3.3V compatible	Keypad input pin 3 / GPIO 08
49	MICP2	I	Audio Interface	Analog	Handset microphone reference
50	CAP19/GPIO	I/O	Capture Compare / GPIO	CMOS 3.3V compatible	Capture Compare 19 / GPIO 47
51	MICN2	I	Audio Interface	Analog	Handset microphone bias

52	CAP02/GPIO	I/O	Capture Compare / GPIO	CMOS 3.3V compatible	Capture Compare 02 / GPIO 57
53	AUOP	O	Audio Interface	Analog	Balanced power audio out
54	CAP05/GPIO	I/O	Capture Compare / GPIO	CMOS 3.3V compatible	Capture Compare 05 / GPIO 28
55	AUON	O	Audio Interface	Analog	Balanced power audio out
56	CAP06/GPIO	I/O	Capture Compare / GPIO	CMOS 3.3V compatible	Capture Compare 06 / GPIO 30
57	ADC1	I	Measurement interface	ADC 12bits 0-2.5V	Analog to Digital Converter
58	CAP00_EX5IN/GPIO	I/O	Capture Compare / GPIO / External Interrupt	CMOS 3.3V compatible	Capture Compare 00 / GPIO 30 / Ext Int 5B
59	ADC2	I	Measurement interface	ADC 12bits 0-2.5V	Analog to Digital Converter
60	CAP22_EX3IN/GPIO	I/O	Capture Compare / GPIO / External Interrupt	CMOS 3.3V compatible	Capture Compare 22 / GPIO 55 / Ext Int 3

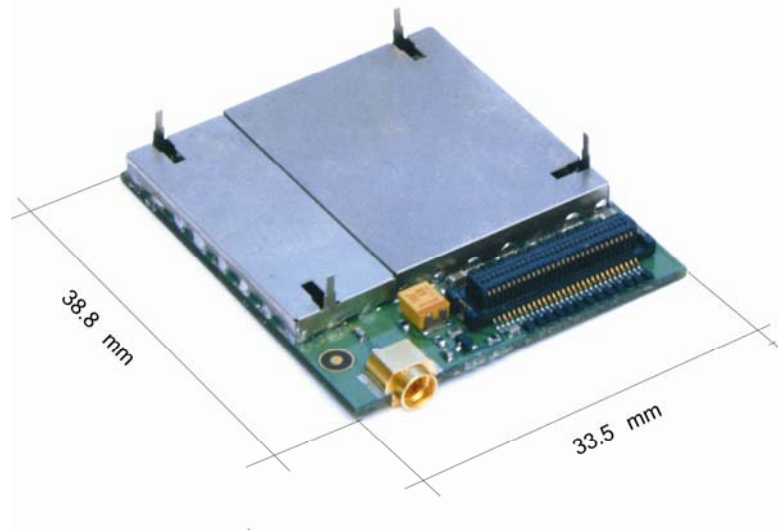

3.1 Fig. TM2 module

3.1 SIM Interface

TM2 module can be equipped with an on-board SIM connector or an external SIM connector. High-speed SIM/ME interface is implemented. Both 1.8V and 3V SIM type will be supported (1.8/3V ME); activation and deactivation with automatic voltage switch from 1.8V to 3V are implemented, according to ISO-IEC 78-16-e Specifications. The SIM driver supports the PPS (Protocol and Parameter Selection) procedure for baud-rate selection, according to the values proposed by the SIM Card. Clock stop is supported at both high and low level. Finally, external SIM ESD protection is required.

Name	PIN #	I/O	I/O type	Description
SIM_VCC	13	I/O	Supply 1.8V 3.3V	SIM Power Supply
SIM_IO	15	I/O	CMOS 3.3V compatible	SIM I/O Serial Data
SIM_CLK	17	O	CMOS 3.3V compatible	SIM Clock Signal
SIM_RST	19	O	CMOS 3.3V compatible	SIM Reset Signal

3.2 Battery

The supported type for the battery shall be Li-Ion rechargeable only; default system will support 650mAh nominal. Protection circuitry is integrated on the module. The Battery/Charger functionality provides:

- battery charging control, i.e. constant voltage charging and trickling of charging in order to maintain the full capacity of the battery;
- pulse charge mode, to improve capacity estimation accuracy;
- capacity estimation during charging, no charging, ongoing calls, etc., constantly considering the different load parameters of the phone;
- Measurements of battery voltage, RF and battery temperature, equipment status, etc.

Charging of deeply discharged battery as well as charging during phone call is possible.

The module has a current consumption lower than 3mA during idle mode reception, lower than 300 mA in connected mode on GSM band and lower than 180mA in connected mode on DCS band (measurements are performed following the GSM Association Battery Life Measurement Technique Document). The charging battery range goes from 400 to 1100 mA with a step of 100 mA.

Name	PIN #	I/O	I/O type	Description
VBAT	1	PWR	From 3.3 to 4.3 V (Typ: 3.8 V)	Should be connected with pins 3, 5, 7
GND	2	PWR	Ground	Should be connected with pins 4, 6, 8
VBAT	3	PWR	From 3.3 to 4.3 V (Typ: 3.8 V)	Should be connected with pins 1, 5, 7
GND	4	PWR	Ground	Should be connected with pins 2, 6, 8
VBAT	5	PWR	From 3.3 to 4.3 V (Typ: 3.8 V)	Should be connected with pins 1, 5, 7
GND	6	PWR	Ground	Should be connected with pins 2, 4, 8
VBAT	7	PWR	From 3.3 to 4.3 V (Typ: 3.8 V)	Should be connected with pins 1, 5, 7
GND	8	PWR	Ground	Should be connected with pins 2, 4, 6
VCHARGE	9	PWR	From 0 to 12 V (Typ: 6V) Current limited to 600 mA	Should be connected with pin 11
VCHARGE	11	PWR	From 0 to 12 V (Typ: 6V) Current limited to 600 mA	Should be connected with pin 9

3.3 Antenna interface

A 50 Ohm MMCX connector is provided as antenna connector for GSM functionality.

3.4 Asynchronous Serial interface

Two serial ports (ASC0 UART and ASC1 UART) are supported working at the selected baud rate (default 115.2 kbps): on ASC0 complete 9 pin serial port is supported and power saving wakeup is available. This interface is fully RS232 9-pin logical compliant and support full HW flow control. Default UART configuration implies ASC0 devoted to AT interface, ASC1 available for debug/tracing (only RX/TX lines). These serial interfaces are available complying with V.24 protocol and the signals are:

- TX Data (TXD_0).
- RX Data (RXD_0).
- Request to Send (RTS_0).
- Clear to Send (CTS_0).
- Data Terminal Ready (DTR).
- Data Set Ready (DSR).

To avoid floating if output pins are high-impedance, use pull-up resistors tied to GSM_VDD or pull-down resistors tied to GND. The first 6 pin reported in the table refer at the first serial interface, while the last two refer at the second serial interface.

Name	PIN #	I/O	I/O type	Description	Serial interface #
DCD	10	O	CMOS 3.3V compatible	Data Carrier Detect	Asynchronous Serial Interface 0
DTR	12	I	CMOS 3.3V compatible	Data Terminal Ready	
CTS_0	14	I	CMOS 3.3V compatible	Clear To Send	
RTS_0	16	O	CMOS 3.3V compatible	Request to Send	
RXD_0	18	I	CMOS 3.3V compatible	Receive Serial Data	
TXD_0	20	O	CMOS 3.3V compatible	Transmit Serial Data	
RI	22	O	CMOS 3.3V compatible	Ring Indicator	
DSR	24	O	CMOS 3.3V compatible	Data Set Ready	Asynchronous Serial Interface 1
RXD_1	26	I	CMOS 3.3V compatible	Receive Serial Data	
TXD_1	28	O	CMOS 3.3V compatible	Transmit Serial Data	

3.5 GPIO

All General Purpose I/O (GPIOs) shall be initialized to proper direction / output logic level as soon as possible. If supply is removed from external device, relevant GPIOs should be placed at low logic level, or decoupled.

Name	PIN #	I/O	I/O type	Description
KEYOUT0/GPIO	30	I/O	CMOS 3.3V compatible	Keypad output pin 0 / GPIO 00
KEYOUT1/GPIO	32	I/O	CMOS 3.3V compatible	Keypad output pin 1 / GPIO 50
KEYOUT3/GPIO	36	I/O	CMOS 3.3V compatible	Keypad output pin 3 / GPIO 02
KEYOUT4/GPIO	38	I/O	CMOS 3.3V compatible	Keypad output pin 4 / GPIO 03
KEYOUT5/GPIO	40	I/O	CMOS 3.3V compatible	Keypad output pin 5 / GPIO 04
KEYIN0/GPIO	42	I/O	CMOS 3.3V compatible	Keypad input pin 0 / GPIO 05

KEYIN1/GPIO	44	I/O	CMOS 3.3V compatible	Keypad input pin 1 / GPIO 06
KEYIN3/GPIO	48	I/O	CMOS 3.3V compatible	Keypad input pin 3 / GPIO 08
CAP19/GPIO	50	I/O	CMOS 3.3V compatible	Capture Compare 19 / GPIO 47
CAP02/GPIO	52	I/O	CMOS 3.3V compatible	Capture Compare 02 / GPIO 57
CAP05/GPIO	54	I/O	CMOS 3.3V compatible	Capture Compare 05 / GPIO 28
CAP06/GPIO	56	I/O	CMOS 3.3V compatible	Capture Compare 06 / GPIO 30

Note: The General Purpose I/O is not accessible using AT commands. It could be accessible from internal M2M resursrses only.

3.6 SW interfaces

The AT-command interface provides the service and the functionalities of GSM/GPRS modem. It is possible observe the AT commands of TM2 module in the following table.

Name	Command description
------	---------------------

General Commands

AT+CGMI	Manufacturer identification
AT+CGMM	Request model identification
AT+CGMR	Request revision identification
AT+CGSN	Request product serial number identification
AT+CSCS	Set TE character set
AT+CIMI	Request international mobile subscriber identification
AT+CCID	Card identification
AT+GCAP	Request complete capability list
A/	Repeat last command

Mobile equipment control and status commands

AT+CPAS	Phone activity status
AT+CPWROFF	Switch off the MS
AT+CFUN	Set phone functionality
AT+CBC	Battery charge
AT+CIND	Indicator control
AT+CMER	Mobile termination event reporting
AT+CCLK	Clock
AT+CALA	Alarm
AT+CRSM	Restricted SIM access
AT+CALM	Alert sound mode
AT+CRSL	Ringer sound level
AT+CLVL	Loudspeaker volume level
AT+CMUT	Mute control
AT+CCWE	Call meter maximum event
AT+CSGT	Set greeting text
AT+CALD	Delete alarm
AT+CTZU	Automatic Time Zone Update
AT+CTZR	Time Zone Reporting

AT+CLAC	List all available AT commands
AT+CMEE	Report mobile termination error

Call control commands

AT+CSTA	Select type of address
ATD	Dial command (full support of modifiers: ;,>,I,G)
ATT	Select tone dialing
ATP	Select pulse dialing
ATA	Call answer
ATH	Hook control
ATM	Monitor speaker mode
ATL	Monitor speaker loudness
AT+CMOD	Call mode
AT+CHUP	Hang up call
AT+CEER	Extended error report
AT+VTD	Tone duration
AT+VTS	DTMF and tone generation
ATDL	Redial last telephone number
ATS0	Automatic answer

Network service commands

AT+CNUM	Subscriber number
AT+CSQ	Signal quality
AT+COPS	Operator selection
AT+CREG	Network registration
AT+CPOL	Preferred operator list
AT+COPN	Read operator names

Security commands

AT+CPIN	Enter PIN
AT+CLCK	Facility lock
AT+CPWD	Change password

Phonebook commands

AT+CPBS	Select phonebook memory storage
AT+CPBR	Read phonebook entries
AT+CPBF	Find phonebook entries
AT+CPBW	Write phonebook entry

Short message commands

AT+CSMS	Select message service
AT+CPMS	Preferred message storage
AT+CMGF	Preferred message format
AT+CSAS	Save settings
AT+CRES	Restore settings
AT+CSDH	Show text mode parameters
AT+CNMI	New message indication
AT+CMGR	Read message
AT+CNMA	New message acknowledgement to ME/TA
AT+CMGL	List message
AT+CMGS	Send message
AT+CMGW	Write message to memory
AT+CMSS	Send message from storage

AT+CSMP	Set text mode parameters
AT+CMGD	Delete SMS
AT+CSCA	Service center address
AT+CSCB	Select cell broadcast message types

Supplementary services commands

AT+CCFC	Call forwarding
AT+CCWA	Call waiting
AT+CLIR	Calling line identification restriction
AT+CLIP	Calling line identification presentation
AT+COLP	Connected line identification presentation
AT+COLR	Connected line identification restriction
AT+CAOC	Advise of charge
AT+CACM	Accumulated call meter
AT+CAMM	Accumulated call meter maximum
AT+CPUC	Price per unit and currency table
AT+CHLD	Call related supplementary services
AT+CTFR	Call deflection
AT+CLCC	List current list calls
AT+CSSN	Supplementary service notifications
AT+CUSD	Unstructured supplementary service data
AT+CCUG	Closed user group
AT+CNAP	Calling name presentation

Data commands

AT+CBST	Select bearer service type
AT+FCLASS	Service class selection and identification
AT+CR	Service reporting control
AT+CRC	Cellular result codes
AT+CRLP	Radio link protocol

FAX class 2.0 commands

AT+FDT	Transmit data
AT+FDR	Receive data
AT+FIP	Initialize facsimile parameters
AT+FKS	Session termination
AT+FK	Session termination
AT+FAA	Adaptive answer
AT+FAP	Address & polling capabilities
AT+FBS	Buffer size
AT+FBO	Data bit order
AT+FBU	HDLC frame reporting
AT+FCC	DS capabilities parameters
AT+FCQ	Copy quality checking
AT+FCR	Capability to receive data
AT+FCS	Current session results
AT+FCT	DTE phase C response timeout
AT+FEA	Phase C received EOL alignment
AT+FFC	Format conversion
AT+FHS	Call termination status
AT+FIE	Procedure interrupt enable

AT+FIS	Current session parameters
AT+FIT	Inactivity timeout
AT+FLI	Local ID string
AT+FLO	Set flow control
AT+FLP	Indicate document to poll
AT+FMI	Request manufacturer identification
AT+FMM	Request model identification
AT+FMR	Request revision identification
AT+FMS	Minimum phase C speed
AT+FNR	Negotiation reporting
AT+FNS	Non-standard frame FIF octet string
AT+FND	NSF message data indication
AT+FPA	Selective polling address
AT+FPI	Local polling ID string
AT+FPP	Packet protocol control
AT+FPS	Page status
AT+FPW	Password parameter
AT+FRQ	Receive quality thresholds
AT+FRY	Error correction mode retry count
AT+FSA	Sub Address parameter
AT+FSP	Request to poll

V.24 control and V.25ter commands

ATZ	Reset to default configuration
AT&F	Set to factory defined configuration
AT&C	Circuit 109 (CD) behavior
AT&D	Circuit 108/2 (DTR) behavior
AT&S	DSR override
AT&K	Flow control
AT&W	Store current configuration
AT&V	Display current configuration
AT&Y	Designate a default reset profile
ATI	Request identification information
AT+GMI	Request manufacturer identification
AT+GMM	Request model identification
AT+GSN	Request product serial number identification
AT+GMR	Request revision identification
AT+ICF	DTE-DCE character framing
AT+IFC	DTE-DCE local flow control
AT\Q	Set flow control
AT+IPR	Fixed DTE rate
ATO	Return to on-line data state
ATS2	Escape character
ATS3	Command line termination character
ATS4	Response formatting character
ATS5	Command line editing character
ATS6	Pause before blind dialing
ATS7	Connection completion timeout
ATS8	Command dial modifier time
ATS10	Automatic disconnect delay

ATS12	Escape prompt delay (EPD)
ATE	Command echo
ATQ	Result code suppression
ATV	DCE response format
ATX	Result code selection and call progress monitoring control

Specific AT commands

AT#	Production test command
AT+CGED	GPRS cell environment description
AT+TRACE	Switch on/off trace
AT+XBANDSEL	Select band
AT+XCALLSTAT	Set reporting call status
AT+XGENDATA	Display generation and SW version
AT+XGCNTRD	Read counters of sent or received GPRS data
AT+XGCNTSET	Set/reset counter of sent or received GPRS data
AT+XHANDSFREE	Set hands free mode
AT+XL1SET	Call the L1-specific function
AT+XSIO	Configuration trace and modem (AT) interfaces
AT+NADC	ADC read command
AT+NGPIOC	GPIO select configuration command
AT+NGPIOR	GPIO read command
AT+NGPIOW	GPIO set command
AT+NRNG	Ringer select command

SIM toolkit

AT+STKPRO	SIM-APPL-TK proactive commands
AT+STKTR	SIM-APPL-TK terminal response
AT+STKENV	SIM-APPL-TK envelope
AT+STKPROF	SIM-APPL-TK terminal profile
AT+STKCC	SIM-APPL-TK call control commands
AT+STKCNF	SIM-APPL-TK proactive session status

GPRS AT commands

AT+CGDCONT	Define PDP context
AT+CGEREP	GPRS event reporting
AT+CGQREQ	Quality of service profile (requested)
AT+CGQMIN	Quality of service profile (minimum acceptable)
AT+CGATT	GPRS attach or detach
AT+CGACT	PDP context activate or deactivate
AT+CGDATA	Enter data state
AT+CGAUTO	Automatic response to a network request for PDP context activation
AT+CGPADDR	Show PDP address
AT+CGCLASS	GPRS mobile station class
AT+CGREG	GPRS network registration status
AT+CGSMS	Select service for MO SMS messages

3.7 Audio devices

3.7.1 Handset

A standard handset is supported for normal handset operation on the default audio path.

3.7.2 Headset

One earpiece headset is supported and may be used for voice during calls. The audio path switching from handset to headset is automatic when a rising edge is detected from line CAP22_EX3XIN (Pin 60); the audio path returning to the headset when line CAP22_EX3XIN (Pin 60) return to 0 level.

3.7.3 Microphone

The uplink path can be switched between the handset and the headset microphone. The path switching is driven automatically as described above for the earpiece. The uplink path can be muted.

3.7.4 Hands-free

A true hands-free functionality is implemented using high power loudspeaker, MS microphone and appropriate DSP algorithms for voice band handling (Echo canceller and Automatic Gain control). The product is equipped with a power audio amplifier that can drive an external 8 ohm speaker with 400mW peak. The audio power amplifier can be used as a voice amplifier for the hands free functionality and as a melody player amplifier for ringer functionality. The melody player could be the Midi synthesizer or the tone generator. In order to minimize the clipping of the audio signal, the polarization voltage can be adapted to the voltage supply (battery voltage). The audio signal on the loudspeaker is a mono signal.

3.7.5 Polyphonic ringer

Polyphonic ring-tones can be generated by an internal MIDI synthesizer, which runs at 16 or 32 KHz sample frequency and can sum up to 40 voices at 16 kHz sampling rate.

The synthesizer output is only mono and cannot be mixed with TCH voice path (the two are mutually exclusive). To perform in-band alerting during TCH with voice path open, only Tone Generator can be used. The output samples of the synthesizer are post processed by two modules:

- High Frequency Shelving Filter: This module is implemented as a first order IIR Filter, which is mainly used for high frequency boost in audio signals. Its transfer function can be controlled by 4 filter coefficients.
- Audio Compressor: The audio compressor is a device for manipulating the dynamic range of mono or stereo audio signals. The audio compressor can be controlled by 14 configuration parameters. Polyphonic standard format supported.

The MIDI driver can play:

- MIDI files conforming to:
 - General Midi Level 1.0 with file-format 0 and 1.
 - General Midi Lite 1.0.
- SPMidi (Scalable Polyphony MIDI) files conforming to:
 - SPMidi 1.0.
- iMelody files conforming to:

- iMelody v.1.2 specifications.

3.7.6 ADC interface / Measurement interface

2 inputs for Analog-to-Digital Converter are supported. The resolution of these converters is of 12-bit with a range of 0-2.5 Volt.

Name	PIN	I/O	I/O type	Description
ADC1	57	I	ADC 12bits 0-2.5V	Analog to Digital Converter
ADC2	59	I	ADC 12bits 0-2.5V	Analog to Digital Converter

3.7.7 SPI

The SPI bus includes a clock signal, and two signals for the transmissions of the master and the slave.

Name	PIN	I/O	I/O type	Description
MRST0/GPIO	21	I/O	CMOS compatible 3.3V	Master Receive Slave Transmit
MTRSR0/GPIO	23	I/O	CMOS compatible 3.3V	Master Transmit Slave Receive
SCLK0/GPIO	25	I/O	CMOS compatible 3.3V	Shift Clock

3.7.8 I2C bus interface

The I2C bus interface includes a serial clock and a serial data line.

Name	PIN	I/O	I/O type	Description
SCL/GPIO	27	O	CMOS 3.3V compatible	Serial Clock Line
SDA/GPIO	29	I/O	CMOS 3.3V compatible	Serial Data Line