

# Rayson Bluetooth® Module

## BC04-AF Class2 Module

## BTM-370

### Features

- The module is a Max. 2dBm (Class2) module.
- Bluetooth standard V2.0+EDR conformity.
- Low current consumption :  
**Park, Sniff, Hold and Deep Sleep**
- RF Core 1.8V operation
- Built-in 15-bit Linear Audio Codec
- Embedded 6Mbit Flash Memory
- Integrated Switch-mode Regulator
- Integrated Battery Charger with programmable current
- Interface: USB,UART&PCM(for voice CODEC)
- Full 14 PIO pins available
- HCI/HS/HF/AG/SPP firmware is available
- 4.2V Tolerant LED drivers with intensity control
- RoHS compliant
- Small outline.      **16.5 x 13 x 2.2 mm**

### Applications

- Headsets
- Automotive hands-free kits
- General purpose Bluetooth system requiring an on-chip audio CODEC

### Outline



## Electrical Characteristics

Absolute Maximum Ratings			
Ratings	Min.	Max.	
Storage Temperature	-40 °C	+150 °C	
Supply Voltage VDD	-0.4 V	3.7 V	
Recommended Operating Condition			
Operating Condition	Min.	Max.	
Operating Temperature range	-40 °C	+105 °C	
Supply Voltage VDD	3.0 V	3.6 V	
<b>Power Consumption: VDD=1.8V    Temperature=+20°C    Output power=+4dBm</b>			
Mode	Average		Unit
SCO connection HV3 (no sniff mode) (slave)	24.2		mA
SCO connection HV1 (master) (slave)	37.6		mA
ACL data transfer 921kpbs UART (slave)	30.9		mA
Standby mode (connected to host, no RF activity)	0.10		mA
Parked slave, 1.28s beacon interval, 38.4kpbs UART	0.28		mA
Reset(RESETB low)	57		uA
CODEC	Microphone input and ADC		0.85 mA
	DAC and loudspeaker driver, no signal		1.4 mA

## Block Diagram

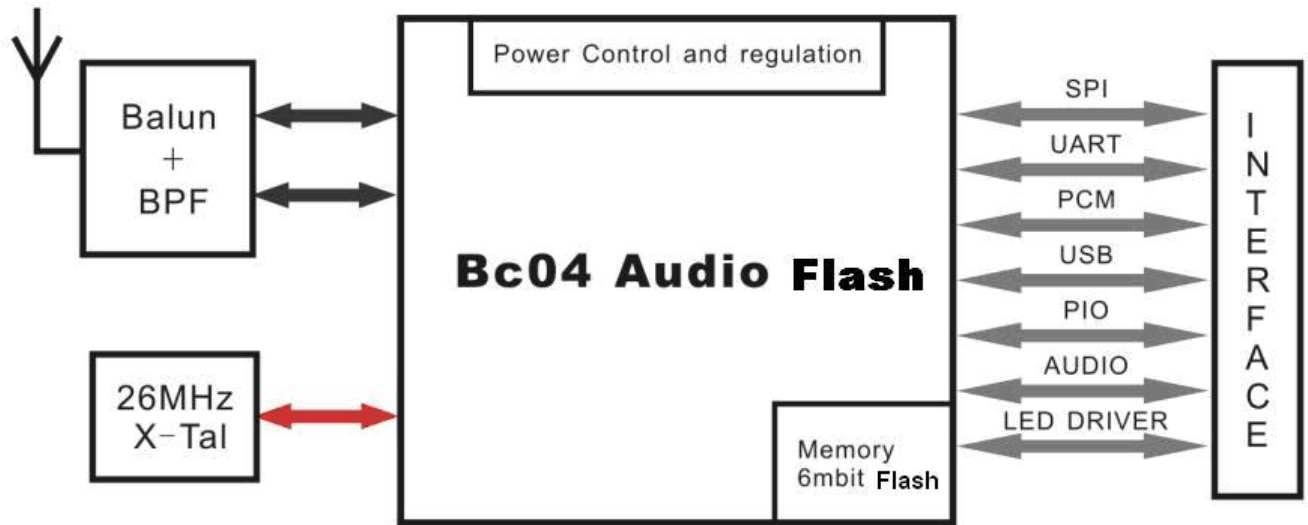

## Audio CODEC Performance

Audio CODEC 15Bit Resolution		Min	Type	Max	Unit
Microphone amplifier	Input full scale at maximum gain	-	3	-	mV rms
	Input full scale at minimum gain	-	350	-	mV rms
	Gain resolution <sup>(1)</sup>	2.8	3.0	3.2	dB
	Distortion at 1KHz	-	-	-78	dB
	Input referenced rms noise <sup>(2)</sup>	-	5	-	uV rms
	Bandwidth	-	20	-	KHz
	Mic mode input impedance	-	20	-	K $\Omega$
	Input mode input impedance	-	130	-	$\Omega$
Loudspeaker Driver	Output voltage full scale swing(differential)	-	2.0	-	V Pk-Pk
	Output current drive(at full scale swing) <sup>(3)</sup>	10	20	40	mA
	Output full scale current(at reduced swing) <sup>(4)</sup>	-	75	-	mA
	Output -3dB bandwidth	-	18.5	-	KHz
	Distortion and noise(relative to full scale)(32 $\Omega$ load) differential	-	-75	-	dB
	Allowed load: resistive	8	-	OC	$\Omega$
	Allowed load: capacitive	-	-	500	pF

**Note:** (1) 42dB range of gain control(under software control).

(2) Noise bandwidth from 100Hz to 4KHz gain setting > 17dB.

(3) Output for 0.1THD, signal level of 2V Pk-Pk differential.

(4) Output for 1THD, signal level of 1V Pk-Pk differential.

(5)Output swing reduced to 1.2V Pk-Pk differential with 1THD or 0.1V Pk-Pk differential with 0.1THD

## Radio Characteristics – Basic Data Rate

Transmitter Performance		VDD=1.8V Temperature=+20°C				
Parameter	Min.	Type	Max.	Bluetooth Spec.	Unit	
RF transmit power	-	2	-	-6 to +4	dBm	
RF power control range	-	35	-	≥16		
RF power range control resolution	-	0.5	-			
20dB bandwidth for modulated carrier	-	940	-	≤1000	KHz	
Initial carrier frequency tolerance	-	5.0	-	±75	KHz	
Carrier frequency drift	Drift Rate	-	7.0	-	±20	KHz/50uS
	DH1	-	8.0	-	±24	KHz
	DH3	-	9.0	-	±40	KHz
	DH5	-	10	-	±40	KHz
Adjacent characteristic	+/- 2 MHz	-	-45	-	≤- 20	dBm
	+/- 3 MHz	-	-48	-	≤- 40	dBm
	+/- 4MHz	-	<-50	-	≤- 40	dBm
Modulation characteristic	ΔF1avg	-	165	-	140≤ΔF1avg≤175	KHz
	ΔF2avg	-	151	-	115	KHz
	ΔF1avg/ΔF1avg	-	0.99	-	≥0.8	

Receiver Performance		VDD=1.8V Temperature=+20°C				
Parameter	Frequency (GHz)	Min.	Type	Max.	Bluetooth Spec.	Unit
Sensitivity at 0.1% BER for all packet types	2.402	-	-80	-	≤- 70	dBm
	2.441	-	-80	-		dBm
	2.480	-	-80	-		dBm
Maximum receive signal at 0.1% BER		-20	>-10	-	≥- 20	dBm
C/I performance Adjacent channel sensitivity	C/I co-channel	-	7	-	≤11	dB
	F=F <sub>0</sub> +1MHz <sup>(1) (2)</sup>	-	-4	-	≤0	dB
	F=F <sub>0</sub> -1MHz	-	-3	-	≤0	dB
	F=F <sub>0</sub> +2MHz	-	-45	-	≤- 30	dB
	F=F <sub>0</sub> -2MHz	-	-23	-	≤- 20	dB
	F=F <sub>0</sub> +3MHz	-	-48	-	≤- 40	dB
	F=F <sub>0</sub> -5MHz	-	-48	-	≤- 40	dB
	F=F <sub>image</sub>	-	-20	-	≤- 9	dB
Max. level of intermodulation interferers <sup>(3)</sup>		-	-15	-	≥- 39	dBm
Spurious output level <sup>(4)</sup>		-	<-130	-		dBm/Hz

Note: (1) Up to five exceptions are allowed in the Bluetooth V2.0+EDR specification on receiver part.

BlueCore4-ROM guaranteed to meet the C/I performance as specified by Bluetooth V2.0+EDR.

(2) Measured at  $F_0 = 2441\text{MHz}$ .

(3) Measured at  $f_1-f_2=5\text{MHz}$ . Measurement is performed in accordance with Bluetooth RF test RCV/CV/05., i.e., wanted signal at  $-64\text{dBm}$

(4) Measured at unbalanced port of balun. Integrated in  $100\text{KHz}$  bandwidth and normalised to  $1\text{Hz}$ . actual figure is typically below  $-150\text{dBm/Hz}$  except for peaks  $-70\text{dBm}$  at  $1600\text{MHz}$ ,  $-60\text{dBm}$  in band at  $2.4\text{GHz}$  and  $-70\text{dBm}$  at  $3.2\text{GHz}$

## Radio Characteristics – Enhanced Data Rate

Transmitter Performance		VDD=1.8V		Temperature=+20°C		
		Min	Type	Max	Bluetooth Specification	Unit
Maximum RF transmit power <sup>(1)</sup>		-	1.5	-	-6 to +4 <sup>(2)</sup>	dBm
Relative transmit power <sup>(3)</sup>		-	-1.2	-	-4 to +1	dB
$\pi/4$ DQPSK max carrier frequency stability <sup>(3)</sup> $W_0$		-	2	-	$\leq \pm 10$ for all blocks	KHz
$\pi/4$ DQPSK max carrier frequency stability <sup>(3)</sup> $W_i$		-	6	-	$\leq \pm 75$ for all blocks	KHz
$\pi/4$ DQPSK max carrier frequency stability <sup>(3)</sup> $ W_0+W_i $		-	8	-	$\leq \pm 75$ for all blocks	KHz
8DPSK max carrier frequency stability <sup>(3)</sup> $W_0$		-	2	-	$\leq \pm 10$ for all blocks	KHz
8DPSK max carrier frequency stability <sup>(3)</sup> $W_i$		-	6	-	$\leq \pm 75$ for all blocks	KHz
8DPSK max carrier frequency stability <sup>(3)</sup> $ W_0+W_i $		-	8	-	$\leq \pm 75$ for all blocks	KHz
$\pi/4$ DQPSK Modulation Accuracy <sup>(3)</sup> (4)	RMS DEVM	-	7	-	$\leq 20$	%
	99% DEVM	-	13	-	$\leq 30$	%
	Peak DEVM	-	19	-	$\leq 35$	%
8DPSK Modulation Accuracy <sup>(3)</sup> (4)	RMS DEVM	-	7	-	$\leq 13$	%
	99% DEVM	-	13	-	$\leq 20$	%
	Peak DEVM	-	17	-	$\leq 25$	%
In-band spurious emission <sup>(5)</sup>	$F > F_0 + 3\text{MHz}$	-	<-50	-	$\leq -40$	dBm
	$F < F_0 - 3\text{MHz}$	-	<-50	-	$\leq -40$	dBm
	$F = F_0 - 3\text{MHz}$	-	-46	-	$\leq -40$	dBm
	$F = F_0 - 2\text{MHz}$	-	-34	-	$\leq -20$	dBm
	$F = F_0 - 1\text{MHz}$	-	-35	-	$\leq -26$	dB
	$F = F_0 + 1\text{MHz}$	-	-35	-	$\leq -26$	dB
	$F = F_0 + 2\text{MHz}$	-	-31	-	$\leq -20$	dBm
$F = F_0 + 3\text{MHz}$	-	-33	-	$\leq -40$	dBm	
EDR Differential Phase Encoding		99	No errors	-	$\geq 99$	%

**Note:** (1) BlueCore4-Audio ROM firmware maintains the transmit power to be within the Bluetooth V2.0+EDR specification limits.

(2) Class2 RF transmit power range, Bluetooth V2.0+EDR specification.

(3) Measurements methods are in accordance with the Bluetooth V2.0+EDR specification.

(4) Modulation accuracy utilises differential error vector magnitude(DEVM) with tracking of frequency drift.

(5) Bluetooth specification value are for 8DPSK. Three exception are allowed in Bluetooth V2.0+EDR specification.

Receiver Performance		VDD=1.8V Temperature=+20°C				
	Modulation	Min	Type	Max	Bluetooth Specification	Unit
Sensitivity at 0.01% BER <sup>(1)</sup>	$\pi/4$ DQPSK	-	-81	-	$\leq -70$	dBm
	8DPSK	-	-78	-	$\leq -70$	dBm
Maximum Received signal at 0.01% BER <sup>(1)</sup>	$\pi/4$ DQPSK	-	-8	-	$\geq -20$	dBm
	8DPSK	-	-10	-	$\geq -20$	dBm
C/I co-channel at 0.01% BER <sup>(1)</sup>	$\pi/4$ DQPSK	-	10	-	$\leq +13$	dB
	8DPSK	-	19	-	$\leq +21$	dB
Adjacent channel selectivity C/I $F=F_0+1\text{MHz}^{(1) (2) (3)}$	$\pi/4$ DQPSK	-	-10	-	$\leq 0$	dB
	8DPSK	-	-5	-	$\leq +5$	dB
Adjacent channel selectivity C/I $F=F_0-1\text{MHz}^{(1) (2) (3)}$	$\pi/4$ DQPSK	-	-11	-	$\leq 0$	dB
	8DPSK	-	-5	-	$\leq +5$	dB
Adjacent channel selectivity C/I $F=F_0+2\text{MHz}^{(1) (2) (3)}$	$\pi/4$ DQPSK	-	-40	-	$\leq -30$	dB
	8DPSK	-	-40	-	$\leq -25$	dB
Adjacent channel selectivity C/I $F=F_0-2\text{MHz}^{(1) (2) (3)}$	$\pi/4$ DQPSK	-	-20	-	$\leq -20$	dB
	8DPSK	-	-23	-	$\leq -13$	dB
Adjacent channel selectivity C/I $F=F_0+3\text{MHz}^{(1) (2) (3)}$	$\pi/4$ DQPSK	-	-45	-	$\leq -40$	dB
	8DPSK	-	-45	-	$\leq -33$	dB
Adjacent channel selectivity C/I $F=F_0-5\text{MHz}^{(1) (2) (3)}$	$\pi/4$ DQPSK	-	-45	-	$\leq -40$	dB
	8DPSK	-	-45	-	$\leq -33$	dB
Adjacent channel selectivity C/I $F=F_{\text{Image}}^{(1) (2) (3)}$	$\pi/4$ DQPSK	-	-20	-	$\leq -7$	dB
	8DPSK	-	-15	-	$\leq 0$	dB

**Note:** (1) Measurements methods are in accordance with the Bluetooth V2.0+EDR specification.

(2) Up to five exceptions are allowed in the Bluetooth V2.0+EDR specification on receiver part.

BlueCore4-ROM guaranteed to meet the C/I performance as specified by Bluetooth V2.0+EDR specification.

(3) Measured at  $F_0 = 2405\text{MHz}, 2441\text{MHz}, 2477\text{MHz}$ .

## BTM-370 Pins Function

No.	Pin Name	Pin Type	Pin description
1	GND	GND	Common ground
2	RF_IO	Analogue	Antenna interface
3	GND	GND	Common ground
4	PIO[0]	Bi-directional	Programmable I/O terminal, RX Enable
5	PIO[1]	Bi-directional	Programmable I/O terminal, TX Enable
6	PIO[2]	Bi-directional	Programmable I/O terminal , MF button input
7	PIO[3]	Bi-directional	Programmable I/O terminal
8	SPK_N	Analogue	Speaker output negative
9	SPK_P	Analogue	Speaker output positive
10	MIC_N	Analogue	Microphone input negative
11	MIC_P	Analogue	Microphone input positive
12	GND	GND	Common ground
13	1.8V	Power	1.8V Internal Power Output
14	VDD	Power	Connect to 1.8V or 3.3V
15	AIO[0]	Bi-directional	Programmable Input/Output Line , Battery Monitor Input
16	AIO[1]	Bi-directional	Programmable Input/Output Line
17	UART_RTS	CMOS output	UART request to send(active low)
18	UART_TX	CMOS output	UART data output
19	UART_RX	CMOS input	UART data input
20	UART_CTS	CMOS input	UART clear to send(active low)
21	PIO[4]	Bi-directional	Programmable I/O terminal , Mute control output
22	USB_DN	Bi-directional	USB data minus
23	USB_DP	Bi-directional	USB data plus
24	PCM_SYNC	Bi-directional	Synchronous data sync
25	PCM_IN	CMOS input	Synchronous data input
26	PCM_CLK	Bi-directional	Synchronous data clock
27	PCM_OUT	CMOS output	Synchronous data output
28	PIO[5]	Bi-directional	Programmable I/O terminal , Charger Detect
29	RESETB	CMOS input	Reset input (Active low)
30	SPI_CLK	CMOS input	Serial Peripheral Interface clock
31	SPI_MISO	CMOS output	Serial Peripheral Interface data output
32	VB_CHG	Power	Lithium lion battery charger input
33	GND	GND	Common ground
34	VBAT	Power	Battery power input
35	SPI_MOSI	CMOS input	Serial Peripheral Interface data input
36	SPI_CSB	CMOS input	Chip select for Synchronous Serial Interface(active low)
37	LED[1]	Open drain output	Current sink to drive Bluetooth status LED
38	LED[0]	Open drain output	Current sink to drive Charging status LED
39	VREG_EN	CMOS input	Internal Regulator enable control input
40	PIO[9]	Bi-directional	Programmable I/O terminal , Power ON/OFF detect
41	PIO[10]	Bi-directional	Programmable I/O terminal , Volume down input
42	PIO[11]	Bi-directional	Programmable I/O terminal , Volume up input

43	PIO[8]	Bi-directional	Programmable I/O terminal
44	PIO[7]	Bi-directional	Programmable I/O terminal
45	PIO[6]	Bi-directional	Programmable I/O terminal

### Dimension

Unit:mm

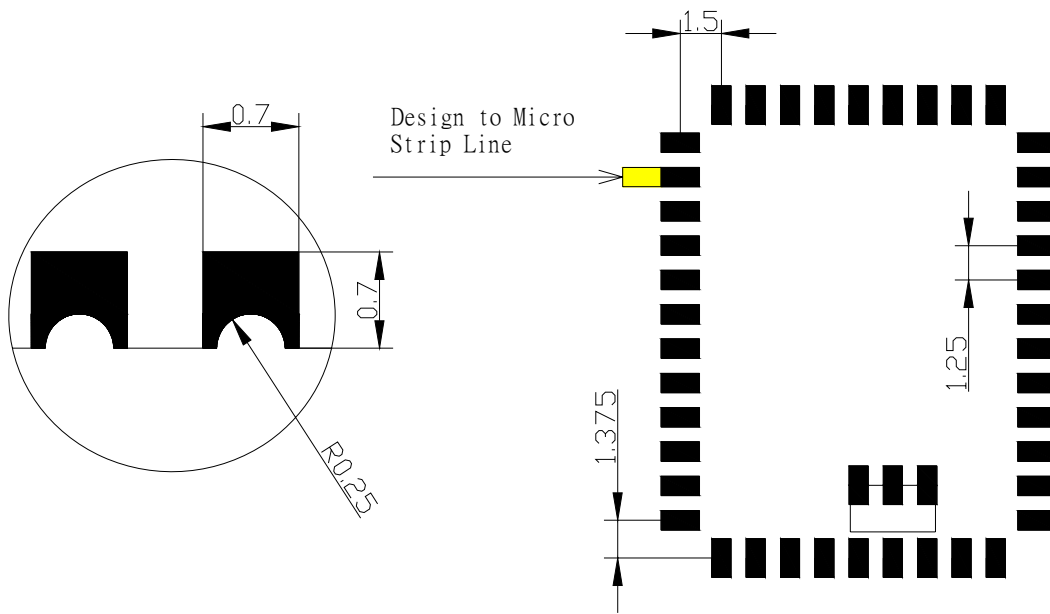
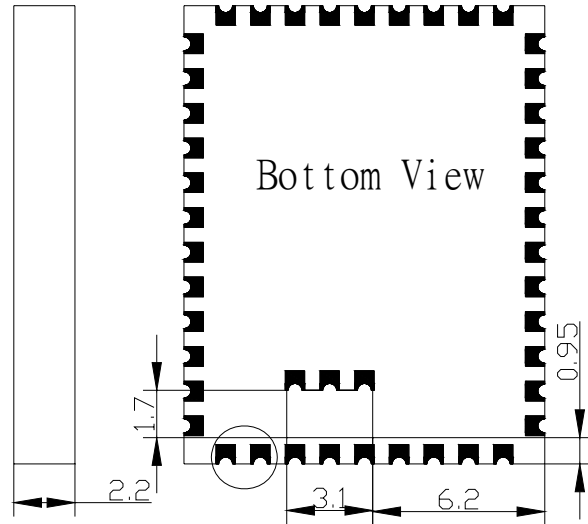
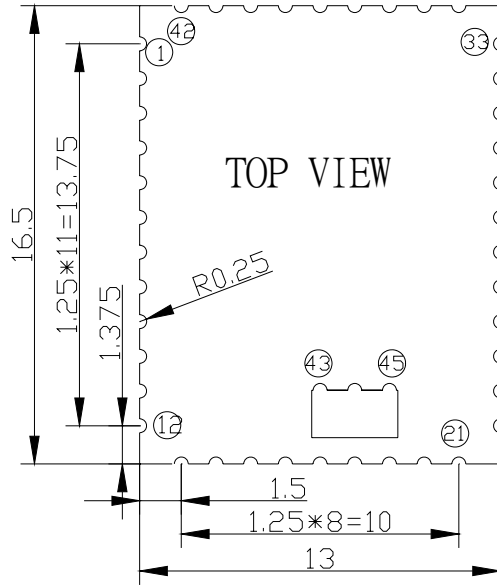

PCB LAYOUT (Top View)

# Headset Application

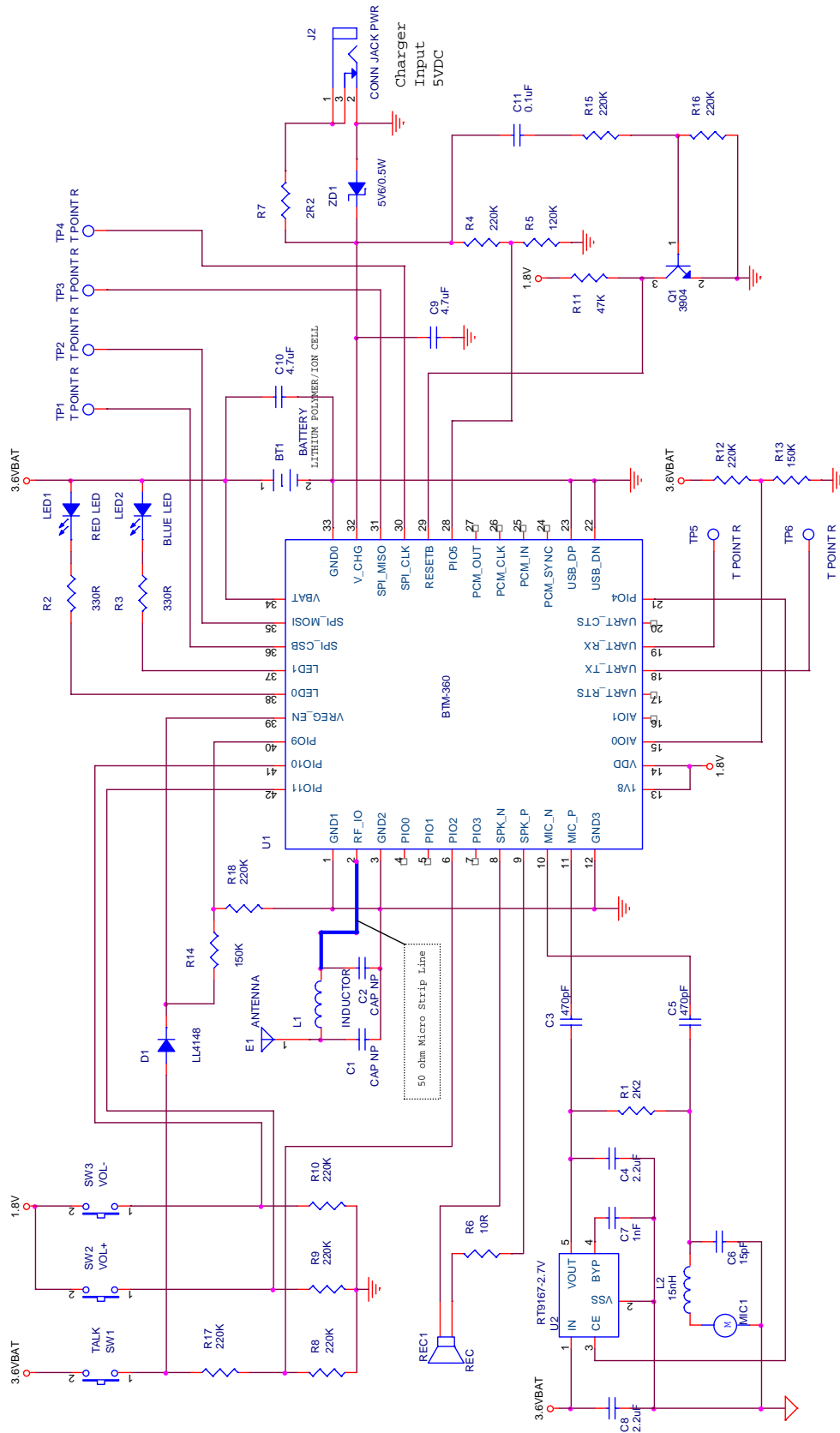

Title	BC3/BC4 Mono Headset
Size	B
Document Number	<Doc>
Rev	<RevCode>
Date:	Wednesday, August 23, 2006
Sheet	1 of 1