

EAGLERISE
伊戈尔
FOR APPROVAL
承认书

客户	CUSTOMER :	
产品名称	TYPE :	LED 电源/LED Power Supply
物料编号	PART NO. :	
主机型号	MODEL NO. :	ELP10X1LS
序列号	SERIAL NO. :	
测试标准	LVD DIRECTIVES : EN61347-2-13:2006, BSEN61347-1:2001 EMC DIRECTIVES : EN55015:2006 EN61547:1995+A1:2000 EN61000-3-3:1995+A1:2001+A2:2005 EN61000-3-2:2006 PROTECTION GRADE : IP20	
RoHS : 按 RoHS 标准 / RoHS STANDARD		<input checked="" type="checkbox"/>
RoHS : 非 RoHS 标准 / Non-RoHS STANDARD		<input type="checkbox"/>
编制	DESIGN :	
批准	APPROVAL :	
客户认可回签(章)	AUTHORIZED SIGNATURE & COMPANY CHOP	

EAGLERISE ELECTRIC & ELECTRONIC (Foshan) CO., LTD.

Add: Guicheng Sci-Tech Industrial Park, Jianping Road, Nanhai District, Foshan City, Guangdong Province, P.R. China
 Tel: (0757) 86259700 86256872 Fax: (0757) 86256788

电气规格

ELECTRICAL SPECIFICATION

一. 电气特性/ ELECTRICAL CHARACTERISTIC

测试点 TEST POINT	参数名称 PARAMETER	技术指标 TECHNIC GUIDELINE	备注 REMARK
1	输入电压 INPUT VOLTAGE	220-240VAC	
	输入电压范围 INPUT VOLTAGE RANGE	176-264VAC	
2	输入频率 INPUT FREQUENCY	50/60Hz	
3	输入电流 INPUT CURRENT	0.09A	
4	电源功率因数 POWER FACTOR	≥ 0.8	在 230V 电压, 45°C 的环境温度下, 满载输出 230V with maximum load at 45 °C
5	空载功耗 POWER CONSUMPTION	$\leq 1W$	
6	输出 OUTPUT	Constant current DC350mA 18-36V	
7	应用负载 load	可带 6-10 个 1W LED 灯串联 6-10Pcs 1W LED LAMP connected in series	
8	效率 EFFICIENCY	$\geq 72\%$	在 230V 电压下, 满载输出 230V with maximum load
9	Ta	45°C	工作温度是指周围的环境温度 Mentioned temperature is the temperature of ambient
10	Tc	80°C	

11	短路保护 SHORT CIRCUIT PROTECTION	拆除后可恢复 resume after replaced	
12	过温保护 OVER TEMPERATURE PROTECTION	过温自动保护, 降温自动恢复 Yes. Reset condition: Auto resume when over temperature is removed	
13	平均寿命 MTBF	≥ 50000 hours	在 25°C 的环境温度下, 满载输出 At maximum load and 25°C ambient temperature
14	绝缘等级 INSULATION CLASS	Class II, SELV	
15	认证标识 CERTIFICATION MARK	SEMKO CE	
16	输出引线长度 SECONDARY SIDE WIRE LENGTH	0.1-4.5M	
17	耐压测试 Electrical strength test	输入——输出 Input----Output 输入——外壳 Input—Enclosure	3750VAC/5mA/1min
18	绝缘电阻 Insulation resistor	$\geq 2M\Omega$	输入——输出 Input----Output
19	外壳颜色 COVER COLOUR	白色/兰色 White/Blue	
20	外形尺寸 DIMENSION	115mm×45mm×27.5mm	
21	环保要求 RoHS	符合 RoHS 要求 Comply with RoHS directive	

二、机械特性 / MECHANICAL CHARACTERISTIC:

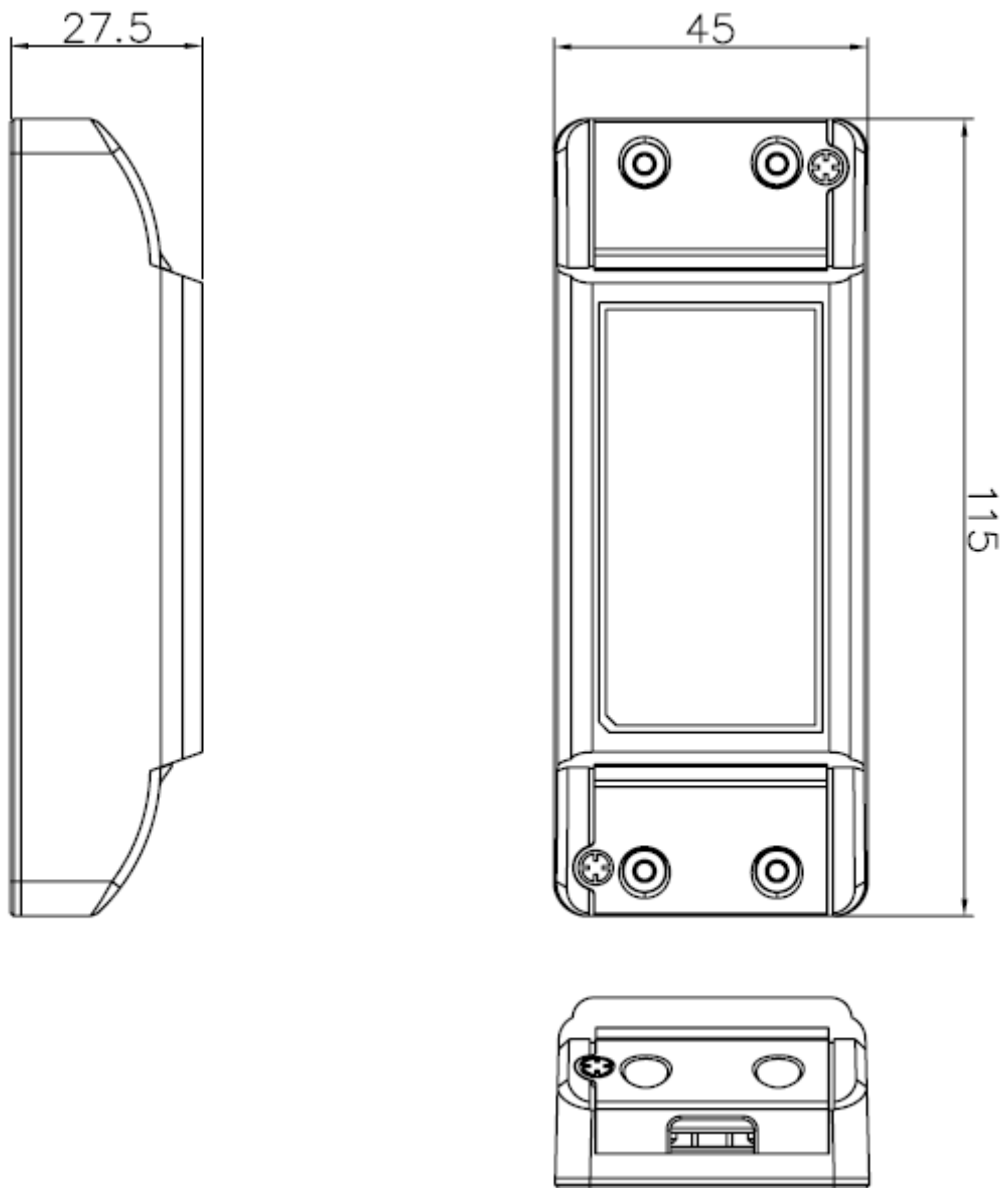

包装规格：标准纸格包装

Packing Spec.: Standard packing with card tray

单位 / Unit: mm